

# iwis

wir bewegen die welt

Product range



**JWIS**<sup>®</sup>

Precision chain systems  
for drive and conveyor purposes

[www.iwis.com](http://www.iwis.com)



# Welcome **iwis**

© Copyright iwis antriebssysteme GmbH & Co. KG, Munich, Germany 2022

The contents of this catalogue are the copyright of the publisher and may not be reproduced (even extracts) unless permission is granted. Every care has been taken to ensure the accuracy of the information contained in this catalogue but no liability can be accepted for any errors or omissions.

Printed: SD EN 05/2022

# to antriebssysteme!

The direct route  
to your order!

You can reach our Customer  
Service Team on weekdays from  
8 am to 6 pm non-stop.

**+49 89 76909-1600**

Or send your order by fax.

**+49 89 76909-1198**

Our Customer Service Team  
will attend to your enquiries  
and orders immediately.

**sales-muenchen  
@iwis.com**

For further information regarding  
our products please visit also  
our company website:

**www.iwis.com**

# Contents **iwis** product

## Our Company







- 2 Welcome
- 4 Contents
- 6 **iwis antriebssysteme**
- 8 **SWTS A brand which stands for highest precision**
- 10 **Highlights, applications and customer benefits**
- 12 **Our service offers**

## Product Range

- 14 **SWTS Roller Chains**
  - 16 according to ISO 606 (British Standard)
  - 18 according to ISO 606 (American Standard)
  - 19 Double-pitch type
- 20 **SWTS Conveyor Chains**
  - 22 with straight attachment plates
  - 24 Excursus: Spike Chains
  - 26 with bent attachment plates
  - 28 Special straight attachment plates
  - 30 Special bent attachment plates
  - 31 with extended bearing pins
  - 32 Multiple strand connecting links
  - 33 with U-shaped attachments
- 34 **SWTS Rapid Service for Conveyor Chains**
- 40 **SWTS MEGAlife Maintenance-free Chains**
  - 44 MEGAlife I – Roller Chains
  - 45 Roller Chains with straight side plates
  - 46 Conveyor Chains with straight att. plates
  - 47 Conveyor Chains with bent attachment plates
  - 48 Conveyor Chains with extended pins
  - 49 MEGAlife II – Roller Chains
  - 50 Special chain designs
  - 51 Accumulation Chains
- 54 **SWTS CF Stainless Steel Chains**

# range

## Product Range

- 62  **dry** maintenance-free  
Stainless Steel Chains
- 66  **CR Chains:**  
corrosion-resistant Chains
- 70  **b.triton**  
corrosion-resistant Chains
- 74  **Accumulation Chains**
- 76 Product range
- 78 MEGAlife Accumulation Chains
- 80 with offset transport rollers
- 82 Standard Accumulation Chains
- 84  **smart** Accumulation Chains
- 84 with finger and small parts protection
- 85 Side Bow Accumulation Chains
- 86 Important information
- 87 Accessories
- 88  **Special Conveyor Chains**
- 90 Grip Chains
- 95 Tube Conveyor Chains
- 96 Pin Oven Chains
- 98 Push Pull Chains
- 100 Plate Chains
- 102 Transfer Chains
- 105 Hollow Pin Chains
- 106 Pallet Transporting Chains
- 106 Side Bow Chains
- 107 Leaf Chains

## Drive Line Products

- 108  **Chain Condition Monitoring**
- 112 **CLA Lubrication System**
- 116  **Sprockets and Plate Wheels**
- 120  **Tools**
- 132  **Automatic Tensioners**

## Chain Guide

- 146 **Perfect Lubrication**
- 147 **Efficient Chain Maintenance**
- 148 **Lubricants**
- 151 **Relubricants**
- 152 **Chain Engineering**
- 153 **Chain Guidelines**

# iwis

Shareholders of the families  
Winklhofer, Bielenberg, Hülshoff

Advisory  
Board

iwis SE & Co. KG  
HR / Finance / Controlling / IT

Automotive

Industry

Mechatronics

**iwis mobility systems**  
GmbH & Co. KG

**iwis antriebssysteme**  
GmbH & Co. KG  
**iwis antriebssysteme** GmbH

**iwis mechatronics** GmbH & Co. KG  
**iwis smart connect** GmbH  
**iwis e-tec** GmbH

Timing, camshaft, mass balancing and oil pump drives for the automotive industry, modular conrod VCS™ (Variable Compression Ratio System).

Precision roller chains, flat top chains, sprockets and chain tensioners for drives and conveyors, agricultural machine drive chains, technical service provider for industrial drive systems.

Precision stamped/bent sheet-metal components for the automotive and aerospace industries, electronic engineering, IT and communication technology, control and sensor technology and the mechanical, plant and equipment engineering industries.

## Our industrial product brands

**JWTS**®

**EURO  
CHAIN**®  
powered by iwis

**ecoplus**®

**FLEXON**®

**ELITE**

Munich (DE)  
Landsberg (DE)

Munich (DE)

Wilnsdorf (DE)

Sontra (DE)



## The journey of those striding ahead

A company which has developed over **115 years** has a story. The entrepreneurial family Winklhofer has been managing the fate of the company iwis since decades and has developed it into a group of companies which committed itself to tradition, precision and innovation. This group of companies produces high precision roller chains and systems for the automotive industry, the machine and plant manufacture, the packaging, printing and food industries, the agriculture and for industrial applications in the field of conveyor technology. More than 3200 employees worldwide at in more than 50 subsidiaries have committed themselves to a quality standard on the highest level.

Our consequent customer orientation in all areas lead to a close cooperation with our customers and suppliers as well as to joint technical developments – as our goal is to always offer our customers a solution at the highest quality and sustainability level. Research and development play a major role in our company's philosophy: The detection of new trends and the development of new materials and production technologies require an innovative power and motivation of which we are proud of and which explain our top position in the market. Thus iwis antriebsysteme GmbH & Co. KG is a worldwide driving force in the general machine manufacture and delivers precision chain systems which move all around the world.



# A brand which stands for highest precision.



Technical perfection of highest quality for a maximum customer benefit – that is our high standard. 100% exact replication of more than 30 million spare parts every single day – a quality benchmark which a single expression stands for at iwis: Highest precision. We are proud of that fact and numerous certifications and awards in the quality sector shows us that we follow the right path!







# Precision for your success



## Technical perfection

- Use of high quality quenched, tempered and case-hardened steels
- High precision fabrication via SPC (statistical process control)
- Quality assurance complying with ISO 9001
- Optimisation of quality features via special heat treatment
- Constant monitoring of the chains for dimensional accuracy and articulation
- Surface coatings
- Special lubricants
- Special materials (e.g corrosion-proof)

## Highest possible quality

- Above average length of life
- Excellent wear resistance
- Restricted length tolerances down to 1/6 of the DIN tolerance
- Significantly higher fracture-resistance than the norm
- High fatigue strength
- iwis roller chains are pretensioned
- Extremely efficient initial lubrication

## Benefits to the user

- Longer maintenance intervals
- Maintenance-friendly, easy and quick to dismantle
- Fewer down times
- Benefits of parallel and synchronous running
- Extremely precise positioning
- Extremely quiet running
- Safety reserves at load peaks
- Reduced stretching during running-in

## Application fields

- Printing presses
- Paper manufacturing and processing machines
- Copiers
- Ceramics and glass industry
- Packaging machines
- Medical technology
- Textile machines
- Machine tools
- Machines for processing plastics
- General engineering and systems construction
- Woodworking machinery
- Agricultural machinery
- Office equipment
- Building materials industry
- Construction machinery
- Conveyor technology
- Chemical engineering and process technology
- Tube and can industry

# Your perfect engineering partner



## A scientific based company

iwis has the largest chain Research and Development department in Europe, having more than 60 development engineers solely engaged for the engineering of chain drive systems. Besides basic development and designing innovative customer solutions, the main focus of iwis Research and Development division ranges from calculations, design and testing to wear elongation and fatigue strength analysis.

- Special knowledge of noise emission analysis and vibration engineering
- Our laboratory has the capabilities to carry out many different testing possibilities including microscopy, metallography, evaluation of mechanical properties, chemical composition and qualified analysis of data
- Dynamic simulation/analysis of chain drive systems with regard to chain load, torsional vibrations and friction losses
- FEM analysis of individual chain drive parts – static and dynamic stress and strength investigations
- Evaluation of iwis and customer readings at test facilities for verification of simulation models
- Identification of thermal characteristics of chain drives while testing in the climate-testing laboratory.



Evaluation of chain breaking strength and elongation up to 1000 kN



More than 25 pulser are available for testing dynamic fatigue strength according to different testing methods



Testing of chain wear elongation behaviour on more than 20 test rigs



## Troubleshooting

Each customer problem is a challenge for us. Either you need a special conveyor chain or perhaps an own chain configuration, integrating chain wheels and guides in existing modules – as a system manufacturer our specialists offer you individual solutions, which go far beyond the chain focus on the entire application and answer your problem as a whole.

Our research and development department stands for creativity and innovation, as well as for a cooperation hand in hand with our customers. Do not hesitate to contact us in case you have a special problem.

## Extreme flexibility

Offering solutions for individual customer problems as well, is our speciality and part of our company's philosophy. By conducting feasibility studies hand in hand with our customers, producing components and executing deformation and stress tests we are able to adjust existing products to individual customer requirements or to develop new chain drives. By means of vibration and stress tests of the components the physical properties of the chain are examined. We try the prototypes on test stands which expose the chain drives to extreme conditions and pressure to ensure its durability and life time. Our customers can and have to be sure that they receive a high quality product – that is our requirement.

# iwis – your strong partner

The iwis group goes global. By supporting own affiliated companies in Great Britain and Switzerland as well as sites in India, Korea, Brazil, South Africa, China, France and the USA the iwis group operates internationally. iwis products are being sold by distribution partners in more than 30 countries on all continents.

## outside Germany as well

iwis has realised the chances of the globalisation at an early stage and has established a distribution structure by a targeted positioning which guarantees a worldwide supply. Thus we do not only open up new markets but our customers can appeal to a familiar and reliable local partner with regard to their business activities abroad.

You are important to us and therefore we are happy to support you in word and deed. Let our competent specialists of our technical service team and our committed external force advise you. We would like to do calculations and chain designs for you and give you advice as far as your choice of the right chain for your applications is concerned. You can reach our Customer Service Team at any time on weekdays from 8 am to 6 pm. And by the way: We are happy to service you during the operating time of the chain as a reliable partner in all matters that arise right around the iwis chain.

## Our service for our customers



# JWTS<sup>®</sup> Roller Chains

are characterised by an above-average service life due to excellent wear resistance, high consistency, matchless precision and a considerably higher breaking strength and fatigue strength than required by ISO standard. All iwis chains are pre-stretched and are provided with a highly efficient initial lubrication.

iwis SL series chains (Super Longlife) have pins with an extremely hard surface. This special design shows outstanding characteristics: Highest wear resistance, a prolonged service life, high breaking and fatigue strength, low susceptibility to deficient operational lubrication, corrosion and frictional corrosion in the chain links.





## **iwis®** Roller Chains, British Standard according to ISO 606 and iwis standard

ISO	iwis reference	Pitch p (")	Pitch p (mm)	Ave. tensile strength $F_a$ (N)	Min. tensile strength $F_{\min}$ (N)	Bearing area $F$ (cm <sup>2</sup> )	Weight per m $q$ (kg/m)	$b_1$ (mm) min.	$b_2$ (mm) max.	$g$ (mm) max.	$a_1$ (mm) max. <sup>2)</sup>	$a$ (mm) max. <sup>2)</sup>	Roller $d$ (mm) max.	Pin $d$ (mm) max.
<b>Simplex</b>														
04	G 42	6 x 2.8 mm	6.00	3,200	3,000	0.07	0.12	2.80	4.10	5.00	6.70	7.60	4.00	1.85
05 B-1	G 52	8 mm x 1/8"	8.00	6,000	4,400	0.11	0.18	3.16	4.85	7.10	8.10	9.20	5.00	2.31
-	G 53 HZ <sup>1) 3)</sup>	8 mm x 3/16"	8.00	8,500	-	0.25	0.34	4.76	7.90	7.60	11.70	-	5.00	3.15
06 B-1	G 67 <sup>1)</sup>	3/8 x 7/32"	9.525	10,500	8,900	0.28	0.41	5.72	8.53	8.20	12.90	14.10	6.35	3.31
-	P 83 V	1/2 x 3/16"	12.70	15,500	-	0.29	0.44	4.88	7.97	10.20	13.20	14.10	7.75	3.68
-	S 84 V	1/2 x 1/4"	12.70	18,000	-	0.38	0.58	6.40	9.65	12.00	15.00	16.00	7.75	3.97
08 B-1	L 85 SL*	1/2 x 5/16"	12.70	22,000	17,800	0.50	0.70	7.75	11.30	11.80	16.90	18.50	8.51	4.45
10 B-1	M 106 SL*	5/8 x 3/8"	15.875	27,000	22,200	0.67	0.95	9.65	13.28	14.40	19.50	20.90	10.16	5.08
12 B-1	M 127 SL*	3/4 x 7/16"	19.05	32,700	28,900	0.89	1.25	11.75	15.62	16.40	22.70	23.60	12.07	5.72
16 B-1	M 1611*	1" x 17 mm	25.40	75,000	60,000	2.10	2.70	17.02	25.45	21.10	36.10	36.90	15.88	8.28
20 B-1	M 2012	1 1/4 x 3/4"	31.75	120,000	95,000	2.92	3.72	19.56	29.01	25.40	40.50	46.30	19.05	10.19
24 B-1	M 2416	1 1/2 x 1"	38.10	211,000	160,000	5.50	7.05	25.40	37.92	33.50	53.10	60.00	25.40	14.63
28 B-1	M 2819	1 3/4 x 31 mm	44.45	250,000	200,000	7.35	8.96	30.95	46.58	37.00	63.60	69.90	27.94	15.90
32 B-1	M 3219	2" x 31 mm	50.80	315,000	250,000	8.05	10.00	30.95	45.57	42.30	65.10	70.10	29.21	17.81

<sup>1)</sup> Straight side plates <sup>2)</sup> Varying dimensions for cranked links <sup>3)</sup> Bush chain

\* Easy break – chains with shouldered pins

The suffix **SL** indicates chains with particular **wear-resistant pins**.

It should be noted that if cranked links are fitted, the breaking strength of the chain may be reduced by approximately 20 %.

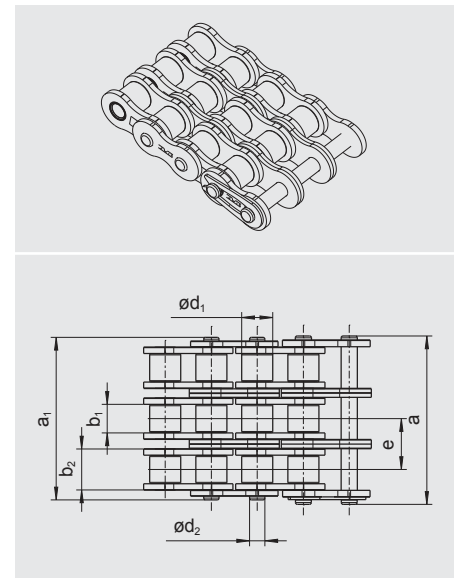
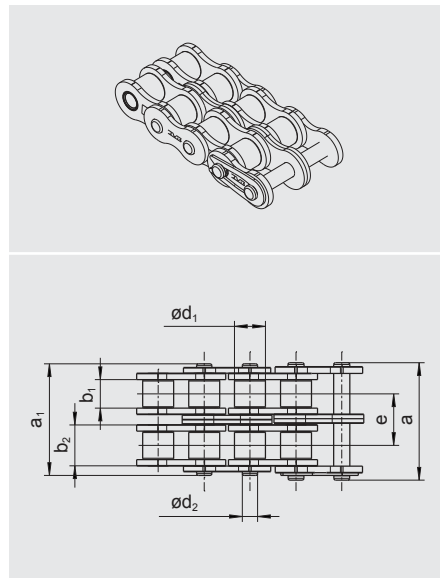
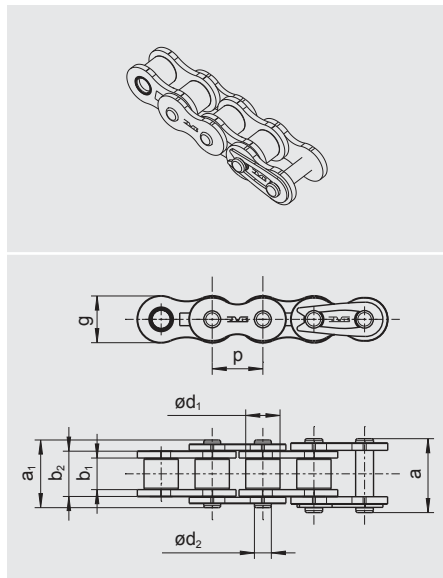



## **iwis**® Roller Chains, British Standard according to ISO 606 and iwis standard

ISO	iwis reference	Pitch p (")	Pitch p (mm)	Ave. tensile strength $F_a$ (N)	Min. tensile strength $F_u$ (N)	Bearing area $F$ (cm <sup>2</sup> )	Weight per m $q$ (kg/m)	$b_1$ (mm) min.	$b_2$ (mm) max.	$g$ (mm) max.	Inner link		Outer link		Roller d (mm) max.	Pin $d_2$ (mm) max.	Transverse pitch $e$ (mm)
											$a_1$ (mm) max. <sup>2)</sup>	$a$ (mm) max. <sup>2)</sup>					
<b>Duplex</b>																	
05 B-2	D 52	8 mm x 1/8"	8.00	9,100	7,800	0.22	0.36	3.16	4.85	7.10	13.90	15.00	5.00	2.31	5.64		
06 B-2	D 67 <sup>1)</sup> *	3/8 x 7/32"	9.525	20,000	16,900	0.56	0.78	5.72	8.53	8.20	23.40	24.60	6.35	3.31	10.24		
08 B-2	D 85 SL*	1/2 x 5/16"	12.70	40,000	31,100	1.00	1.35	7.75	11.30	11.80	30.80	32.40	8.51	4.45	13.92		
10 B-2	D 106 SL*	5/8 x 3/8"	15.875	56,000	44,500	1.34	1.85	9.65	13.28	14.40	36.00	37.50	10.16	5.08	16.59		
12 B-2	D 127*	3/4 x 7/16"	19.05	68,000	57,800	1.78	2.50	11.75	15.62	16.40	42.10	43.00	12.07	5.72	19.46		
16 B-2	D 1611*	1" x 17 mm	25.40	150,000	106,000	4.21	5.40	17.02	25.45	21.10	68.00	68.80	15.88	8.28	31.88		
20 B-2	D 2012	1 1/4 x 3/4"	31.75	210,000	170,000	5.84	7.36	19.56	29.01	25.40	79.70	82.90	19.05	10.19	36.45		
24 B-2	D 2416	1 1/2 x 1"	38.10	370,000	280,000	11.00	13.85	25.40	37.92	33.50	101.80	106.50	25.40	14.63	48.36		
28 B-2	D 2819	1 3/4" x 31 mm	44.45	500,000	360,000	14.70	18.80	30.95	46.58	37.00	124.70	129.20	27.94	15.90	59.56		
32 B-2	D 3219	2" x 31 mm	50.80	530,000	450,000	16.10	19.80	30.95	45.57	42.30	126.00	128.30	29.21	17.81	58.55		
<b>Triplex</b>																	
08 B-3	TR 85*	1/2 x 5/16"	12.70	58,000	44,500	1.50	2.00	7.75	11.30	11.80	44.70	46.30	8.51	4.45	13.92		
10 B-3	TR 106*	5/8 x 3/8"	15.875	80,000	66,700	2.02	2.80	9.65	13.28	14.40	52.50	54.00	10.16	5.08	16.59		
12 B-3	TR 127*	3/4 x 7/16"	19.05	100,000	86,700	2.68	3.80	11.75	15.62	16.40	61.50	62.50	12.07	5.72	19.46		
16 B-3	TR 1611*	1" x 17 mm	25.40	220,000	160,000	6.32	8.00	17.02	25.45	21.10	99.20	100.70	15.88	8.28	31.88		
20 B-3	TR 2012	1 1/4 x 3/4"	31.75	315,000	250,000	8.76	11.00	19.56	29.01	25.40	116.10	119.40	19.05	10.19	36.45		
24 B-3	TR 2416	1 1/2 x 1"	38.10	560,000	425,000	16.50	20.31	25.40	37.92	33.50	150.20	155.40	25.40	14.63	48.36		
28 B-3	TR 2819	1 3/4" x 31 mm	44.45	750,000	530,000	22.05	28.00	30.95	46.58	37.00	184.60	188.90	27.94	15.90	59.56		
32 B-3	TR 3219	2" x 31 mm	50.80	795,000	670,000	24.15	29.60	30.95	45.57	42.30	184.50	186.50	29.21	17.81	58.55		

<sup>1)</sup> Straight side plates <sup>2)</sup> Varying dimensions for cranked links

\* Easy break – chains with shouldered pins

The suffix **SL** indicates chains with particularly **wear-resistant pins**.

It should be noted that if cranked links are fitted, the breaking strength of the chain may be reduced by approximately 20 %.

### CHAIN COMPONENTS AND CONNECTING LINKS



Inner link  
Standard designation B

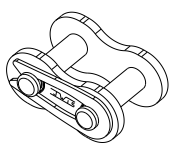

Connecting link  
with spring clip  
Standard designation E

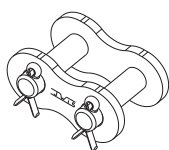

Connecting link  
with split pin fastening  
Standard designation S

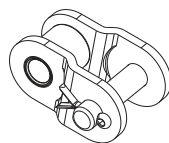

Single cranked link  
with split pin fastening  
Standard designation L

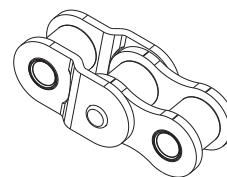

Double cranked link  
Standard designation C

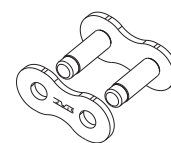

Outer link  
Standard designation A

## **iwis**® Roller Chains, American Standard (ANSI) according to ISO 606

ISO	iwis-reference	ANSI Ref. no.	Pitch p (°)	Pitch p (mm)	Ave. tensile strength $F_a$ (N)	Min. tensile strength $F_u$ (N)	Bearing area $F$ (cm <sup>2</sup> )	Weight per m $q$ (kg/m)	$b_1$ (mm) min.	$b_2$ (mm) max.	Inner link			Outer link			Transverse pitch $e$ (mm)
											$g$ (mm) max.	$a_1$ (mm) max. <sup>2)</sup>	$a$ (mm) max. <sup>2)</sup>	Roller $d_1$ (mm) max.	Pin $d_2$ (mm) max.		
<b>Simplex</b>																	
04 C-1	G 42 A	25-1	1/4	6.35	4,909	3,500	0.11	0.13	3.18	4.80	5.80	7.820	8.62	3.30	2.31	-	
06 A-1	G 67 A	35-1	3/8	9.55	10,983	7,900	0.27	0.32	4.78	7.46	9.04	11.96	12.93	5.08	3.60	-	
08 A-1	L 85 A	40-1	1/2	12.70	18,000	13,900	0.44	0.60	7.92	11.17	12.06	16.60	18.54	7.95	3.98	-	
10 A-1	M 106 A	50-1	5/8	15.875	29,000	21,800	0.70	1.01	9.53	13.84	15.08	20.40	22.55	10.16	5.09	-	
12 A-1	M 128 A SL <sup>1)</sup>	60-1	3/4	19.05	42,000	31,300	1.06	1.47	12.70	17.75	18.09	25.44	27.99	11.91	5.96	-	
16 A-1	M 1610 A	80-1	1	25.40	68,000	55,600	1.79	2.57	15.88	22.60	24.13	33.0	35.0	15.88	7.94	-	
20 A-1	M 2012 A	100-1	1 1/4	31.75	112,776	87,000	2.62	3.95	19.05	27.45	30.16	39.68	43.98	19.05	9.54	-	
24 A-1	M 2416 A	120-1	1 1/2	38.10	152,984	125,000	3.94	5.64	25.40	35.45	36.19	51.06	55.36	22.23	11.11	-	
28 A-1	M 2816 A	140-1	1 3/4	44.45	205,940	170,000	4.73	7.38	25.40	37.18	42.22	54.54	59.44	25.40	12.71	-	
32 A-1	M 3219 A	160-1	2	50.80	256,934	223,000	6.46	9.40	31.55	45.21	48.26	65.52	69.82	25.58	14.29	-	
36 A-1	M 3623 A	180-1	2 1/4	57.15	374,614	281,000	8.88	12.67	35.71	50.85	54.29	73.28	78.78	35.71	17.46	-	
40 A-1	M 4024 A	200-1	2 1/2	63.50	485,429	347,000	10.89	15.90	38.10	54.88	60.32	80.70	86.70	39.68	19.85	-	
48 A-1	M 4830 A	240-1	3	76.20	686,466	500,000	16.15	24.40	47.63	67.81	72.39	98.70	104.70	47.63	23.81	-	
<b>Duplex</b>																	
04 C-2	D 42 A	25-2	1/4	6.35	9,218	7,000	0.22	0.25	3.18	4.80	5.80	14.22	15.02	3.30	2.31	6.40	
06 A-2	D 67 A	35-2	3/8	9.53	21,967	15,800	0.56	0.63	4.78	7.46	9.04	22.42	23.12	5.08	3.60	10.13	
08 A-2	D 85 A	40-2	1/2	12.70	36,000	27,800	0.88	1.22	7.92	11.17	12.06	31.00	32.98	7.95	3.98	14.38	
10 A-2	D 106 A	50-2	5/8	15.875	56,000	43,600	1.40	2.00	9.53	13.84	15.08	38.60	40.72	10.16	5.09	18.11	
12 A-2	D 128 A <sup>1)</sup>	60-2	3/4	19.05	84,000	62,600	2.12	2.90	12.70	17.75	18.09	48.20	50.83	11.91	5.96	22.78	
16 A-2	D 1610 A	80-2	1	25.40	145,000	111,200	3.58	5.05	15.88	22.60	24.13	62.20	64.30	15.88	7.92	29.29	
20 A-2	D 2012 A	100-2	1 1/4	31.75	225,553	174,000	5.24	7.86	19.05	27.45	30.16	76.28	79.18	19.05	9.54	35.76	
24 A-2	D 2416 A	120-2	1 1/2	38.10	305,967	250,000	7.88	11.20	25.40	35.45	36.19	96.26	100.46	22.23	11.11	45.44	
28 A-2	D 2816 A	140-2	1 3/4	44.45	411,879	340,000	9.46	14.66	25.40	37.18	42.22	103.14	108.54	25.40	12.71	48.87	
32 A-2	D 3219 A	160-2	2	50.80	249,089	446,000	12.92	18.64	31.55	45.21	48.26	124.82	127.62	25.58	14.29	58.55	
36 A-2	D 3623 A	180-2	2 1/4	57.15	749,228	562,000	17.76	25.14	35.71	50.85	54.29	139.12	144.62	35.71	17.46	65.84	
40 A-2	D 4024 A	200-2	2 1/2	63.50	970,858	694,000	21.78	31.60	38.10	54.88	60.32	152.30	158.30	39.68	19.85	71.55	
48 A-2	D 4830 A	240-2	3	76.20	1,372,931	1,000,000	32.30	48.40	47.63	67.81	72.39	186.60	192.50	47.63	23.81	87.83	
<b>Triplex</b>																	
04 C-3	TR 42 A	25-3	1/4	6.35	13,827	10,500	0.33	0.37	3.18	4.80	5.80	21.06	21.86	3.30	2.31	6.40	
06 A-3	TR 67 A	35-3	3/8	9.53	32,950	23,700	0.81	0.94	4.78	7.46	9.04	32.18	33.28	5.08	3.60	10.13	
08 A-3	TR 85 A	40-3	1/2	12.70	50,000	41,700	1.32	1.82	7.92	11.17	12.06	45.40	47.36	7.95	3.98	14.38	
10 A-3	TR 106 A	50-3	5/8	15.875	80,000	65,400	2.10	2.89	9.53	13.84	15.08	56.70	58.93	10.16	5.09	18.11	
12 A-3	TR 128 A	60-3	3/4	19.05	125,000	93,900	3.18	4.28	12.70	17.75	18.09	71.10	73.71	11.91	5.96	22.78	
16 A-3	TR 1610 A	80-3	1	25.40	210,000	166,800	5.37	7.54	15.88	22.60	24.13	91.40	93.50	15.88	7.94	29.29	
20 A-3	TR 2012 A	100-3	1 1/4	31.75	338,329	261,000	7.86	11.75	19.05	27.45	30.16	112.98	115.88	19.05	9.54	35.76	
24 A-3	TR 2416 A	120-3	1 1/2	38.10	458,951	375,000	11.82	16.73	25.40	35.45	36.19	140.86	145.96	22.23	11.11	45.44	
28 A-3	TR 2816 A	140-3	1 3/4	44.45	617,819	510,000	14.19	21.93	25.40	37.18	42.22	152.24	157.24	25.40	12.71	48.87	
32 A-3	TR 3219 A	160-3	2	50.80	770,803	669,000	19.38	27.89	31.55	45.21	48.26	183.52	185.52	25.58	14.29	58.55	
36 A-3	TR 3623 A	180-3	2 1/4	57.15	1,123,842	843,000	26.64	37.60	35.71	50.85	54.29	210.45	210.46	35.71	17.46	65.84	
40 A-3	TR 4024 A	200-3	2 1/2	63.50	1,456,288	1,041,000	32.67	47.30	38.10	54.88	60.32	223.80	229.80	39.68	19.85	71.55	
48 A-3	TR 4830 A	240-3	3	76.20	2,059,397	1,500,000	48.45	72.40	47.63	67.81	72.39	274.40	280.40	47.63	23.81	87.83	

<sup>1)</sup> Also available with straight side plates <sup>2)</sup> Varying dimensions for cranked links

## **iwis**® Roller Chains, double-pitch type according to ISO 1275

ISO	iwis reference	ANSI Ref. no.	Pitch p (°)	Pitch p (mm)	Ave. tensile strength $F_a$ (N)	Min. tensile strength $F_u$ (N)	Bearing area $F$ (cm <sup>2</sup> )	Weight per m $q$ (kg/m)	$b_1$ (mm) min.	$b_2$ (mm) max.	Inner link		Outer link			Transverse pitch $e$ (mm)
											$g$ (mm) max.	$a_1$ (mm) max. <sup>2)</sup>	$a$ (mm) max. <sup>2)</sup>	Roller $d_1$ (mm) max.	Pin $d_2$ (mm) max.	
<b>Roller Chains, double-pitch type</b>																
208 B	LR 165 SL	-	1	25.40	22,000	18,000	0.50	0.52	7.75	11.30	11.80	16.90	18.60	8.51	4.45	-
210 B	LR 206 SL	-	1 1/4	31.75	28,000	22,400	0.67	0.63	9.65	13.28	15.10	19.50	20.80	10.16	5.08	-
212 B	LR 247 SL	-	1 1/2	38.10	34,000	29,000	0.89	0.85	11.75	15.62	16.10	22.70	24.10	12.07	5.72	-
216 B	LR 3211	-	2	50.80	75,000	60,000	2.10	1.77	17.02	25.45	20.60	36.10	38.10	15.88	8.28	-

<sup>1)</sup> Also available with straight side plates  
<sup>2)</sup> Varying dimensions for cranked links

\* Roller chains with "easy break" shouldered pins – chains are easy to dismantle

It should be noted that if cranked links are fitted, the breaking strength of the chain may be reduced by approximately 20 %. The suffix SL indicates chains with particular wear-resistant pins.

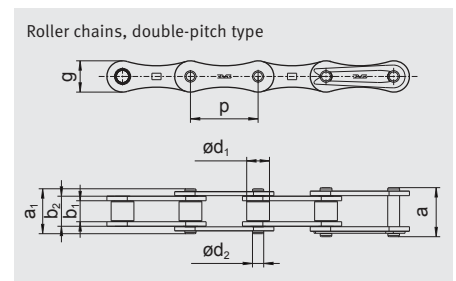

## **iwis**® High Performance Chains

Quality products with a world reputation

### HIGH QUALITY IS BASED ON EACH INDIVIDUAL PART BEING TECHNICALLY PERFECT

- Use of high-grade heat-treatable steels which are made exclusively for iwis to their material analysis, tolerance and surface quality.
- Each chain part is manufactured a million times daily to the same precision. This production is monitored by SPC (statistical process control).
- All chain parts are heat-treated, using special processes to optimize quality features.
- Constant geometry and high surface quality result from the use of modern production technologies.
- Chains are checked for dimensional accuracy: length tolerance, freedom of articulation and assembly component integrity, inspection of the press-in seating of the pin outer links and bush-inner link interfaces.
- The high standard of quality assurance conforms with the high requirements of ISO 9001.
- For special applications
  - Surface coatings
  - Special lubrications
  - Reduced length tolerated chains
  - Special materials (e.g. corrosion resistant)

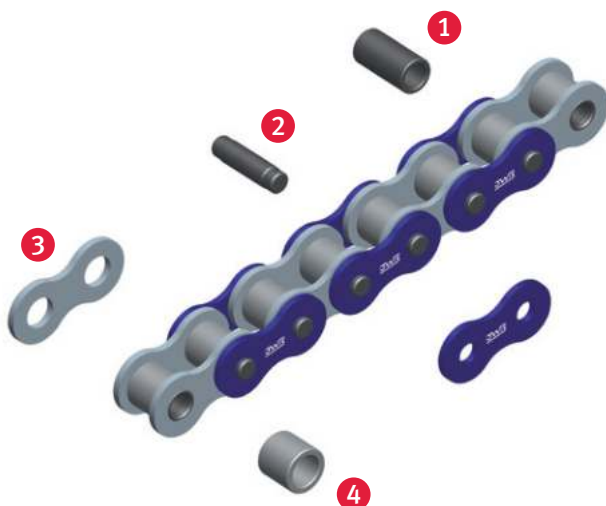

- 1** iwis bush – manufactured as a special, surface treated cylinder and depending on the application seamless or curled
- 2** iwis shouldered pin (ISO 606): SL chains have pins with even higher resistance to wear.
- 3** iwis side plate – optimally dimensioned, shaped with precision, and heat-treated for toughness and hardness.
- 4** iwis roller – an absolutely cylindrical form guarantees ideal sliding-contact bearing properties.

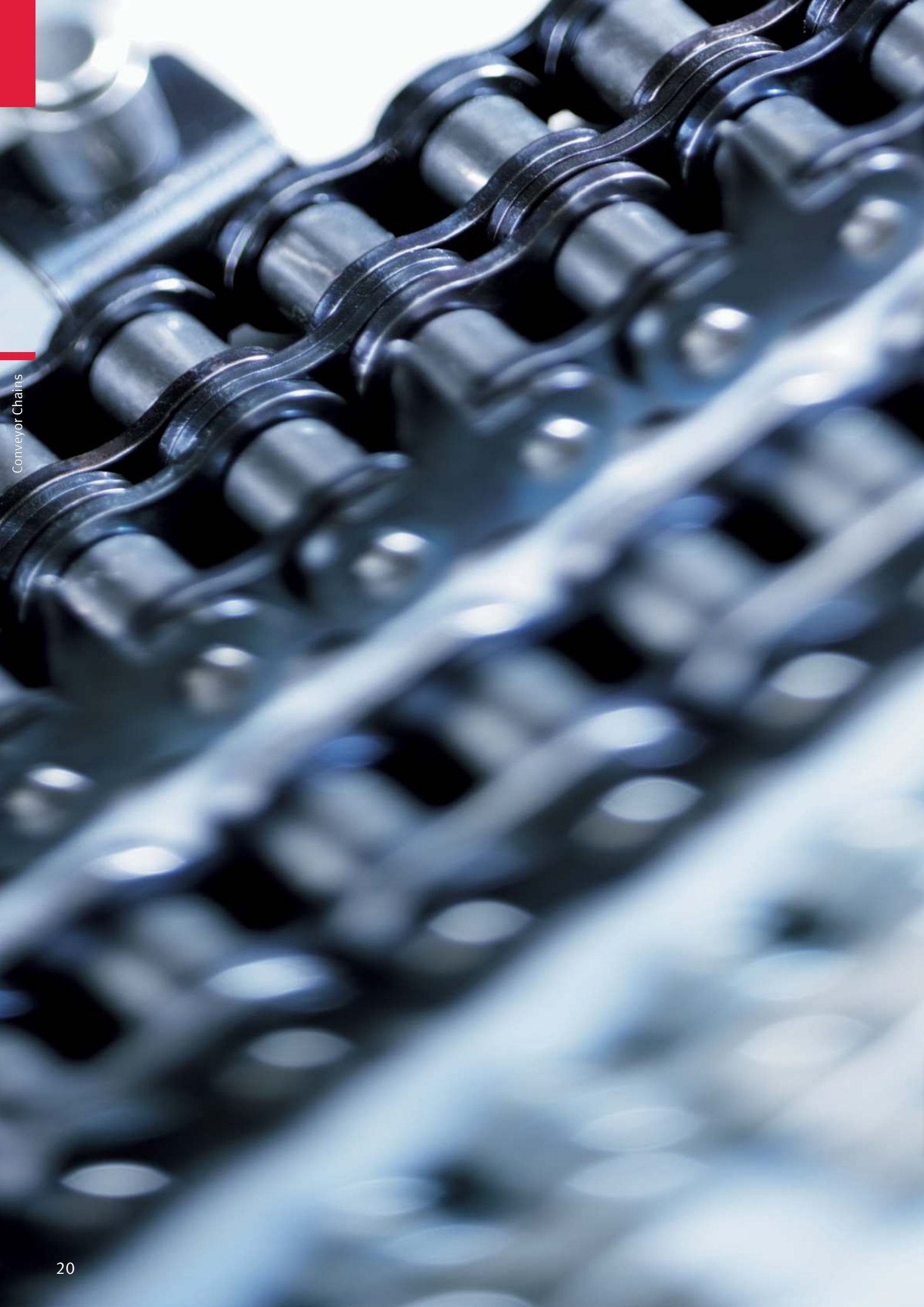

# **JWIS**<sup>®</sup> Conveyor Chains

iwis conveyor chains can especially be matched with the demands of customer applications. iwis does not only supply the customer with a wide range of special straight attachments and bent attachment plates, but the Technical Service Team offers solutions for individual customer demands and designs custom-made products.

iwis conveyor chains offer the user the benefits of parallel and synchronous running, extremely precise positioning, quiet running and a significantly higher breaking resistance than the norm. Also available: conveyor chains with extended bearing pins, conveyor chains with U-shaped attachments and multiple strand connecting links.



## **iwis® Conveyor Chains with straight attachment plates** based on iwis chains complying with ISO 606 and ISO 1275

ISO	iwis reference	P (°)	Pitch <sup>2)</sup>		a (mm)	b (mm)	d (mm)	Single strand chains e <sub>1</sub> (mm)	Double strand chains e <sub>2</sub> (mm)	Triple strand chains e <sub>3</sub> (mm)	g (mm)	i (mm)	l (mm)	s (mm)	M (mm)	Threaded insert m. max (mm)
			P (mm)													
<b>Plate No. 102.1</b>																
-	P 83 V	1/2	12.7	13.0	19.0	4.2	8.1	-	-	4.5	-	18.0	1.5	-	-	-
-	S 84 V	1/2	12.7	13.0	19.0	4.2	9.8	-	-	4.5	-	18.0	1.5	-	-	-
08 B-1	L 85 SL <sup>1)</sup>	1/2	12.7	13.0	19.0	4.2	11.6	25.5	39.4	5.4	-	18.0	1.5	4	5.2	-
10 B-1	M 106 SL <sup>1)</sup>	5/8	15.875	16.3	24.3	5.2	13.6	30.1	46.6	6.8	-	24.0	1.6	5	5.3	-
12 B-1	M 127 SL <sup>1)</sup>	3/4	19.05	19.1	29.1	6.2	15.9	35.3	54.7	7.4	-	28.0	1.8	5	5.5	-
16 B-1	M 1611 <sup>1)</sup>	1	25.4	24.6	36.6	8.2	25.9	57.8	89.7	10.4	-	36.2	3.0	6	8.2	-
08 A-1 ANSI 40	L 85 A <sup>1)</sup>	1/2	12.7	13.0	19.0	4.2	11.4	25.8	40.2	4.5	-	18.0	1.5	-	-	-
10 A-1 ANSI 50	M 106 A <sup>1)</sup>	5/8	15.875	16.3	24.3	5.2	14.1	32.3	50.4	6.8	-	24.0	1.6	-	-	-
12 A-1 ANSI 60	M 128 A SL <sup>1)</sup>	3/4	19.05	19.1	29.1	6.2	18.1	40.8	63.6	7.4	-	28.0	2.4	-	-	-
16 A-1 ANSI 80	M 1610 A <sup>1)</sup>	1	25.4	24.6	36.6	8.2	23.0	52.2	81.5	10.4	-	36.2	3.0	-	-	-
<b>Plate No. 103.1 and 103.2</b>																
-	P 83 V <sup>2)</sup>	1/2	12.7	17.0	23.0	4.2	8.1	-	-	4.5	12.7	23.6	1.5	-	-	-
-	S 84 V	1/2	12.7	17.0	23.0	4.2	9.8	-	-	4.5	12.7	23.6	1.5	-	-	-
08 B-1	L 85 SL <sup>1)</sup>	1/2	12.7	17.0	23.0	4.2	11.6	25.5	39.4	5.4	12.7	23.6	1.5	4	5.2	-
10 B-1	M 106 SL <sup>1)</sup>	5/8	15.875	16.3	25.8	5.2	13.6	30.1	46.6	7.5	15.8	31.0	1.6	5	5.3	-
12 B-1	M 127 SL <sup>1)</sup>	3/4	19.05	18.3	29.0	6.2	15.9	35.3	54.7	9.0	19.0	37.2	1.8	5	5.5	-
16 B-1	M 1611 <sup>1)</sup>	1	25.4	28.45	41.55	8.2	25.9	57.8	89.7	10.35	25.4	47.2	3.0	6	8.2	-
08 A-1 ANSI 40	L 85 A <sup>1)</sup>	1/2	12.7	17.0	23.0	4.2	11.4	25.8	40.2	4.5	12.7	23.6	1.5	-	-	-
10 A-1 ANSI 50	M 106 A <sup>1)</sup>	5/8	15.875	16.3	25.8	5.2	14.1	32.3	50.4	7.5	15.8	31.0	1.6	-	-	-
12 A-1 ANSI 60	M 128 A SL <sup>1)</sup>	3/4	19.05	18.3	29.0	6.2	18.1	40.8	63.6	9.0	19.0	37.2	2.4	-	-	-
16 A-1 ANSI 80	M 1610 A <sup>1)</sup>	1	25.4	28.45	41.55	8.2	23.0	52.2	81.5	10.35	25.4	47.2	3.0	-	-	-
<b>Plate No. 101.1 and 101.2</b>																
208 B	LR 165 SL	1	25.4	14.3	20.5	4.2	11.6	-	-	6.5	14.0	24.2	1.5	-	-	-
210 B	LR 206 SL	1 1/4	31.75	16.3	25.8	5.2	13.8	-	-	7.5	18.0	30.2	1.6	-	-	-
212 B	LR 247 SL	1 1/2	38.1	19.2	29.5	6.2	15.9	-	-	9.0	20.0	36.2	1.7	-	-	-
216 B	LR 3211	2	50.8	28.5	40.6	8.2	25.9	-	-	10.2	28.0	48.2	3.0	-	-	-

<sup>1)</sup> Available for both double and triple strand chains <sup>2)</sup> Nominal pitch

## **iwis® Conveyor Chains with straight attachment plates** based on iwis chains complying with ISO 606 and ISO 1275

### STRAIGHT ATTACHMENT PLATES

The designs shown below can be supplied as connecting links, or outer links for end

fitting or repair. Further threaded inserts can also be supplied. Details on request.

Single



Double

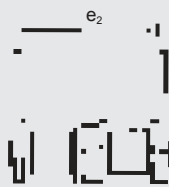

Triple

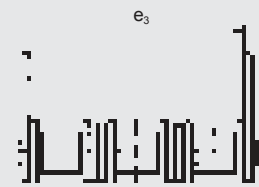

Design 102.1



102.31 with threaded insert

Design 103.1

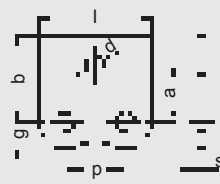

Design 103.2

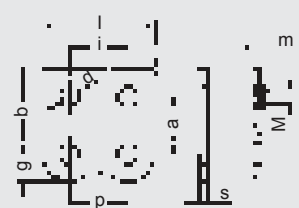

103.32 with threaded insert

Design 101.1 for double-pitch chains

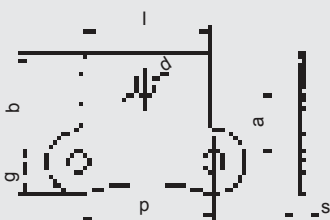

Design 101.2 for double-pitch chains

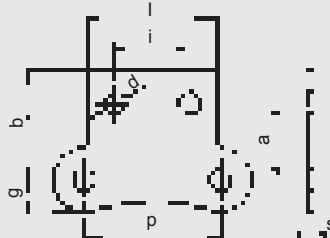

## iwis® Spike Chains for the thermoform industry

EXCURSUS



### PRECISE PRODUCT SOLUTIONS

Our conveyor chains are developed to suit customer specific requirements and applications. They can be manufactured using standard components or specially developed products. With this in mind we present our uniquely developed Thermoform chains which are used throughout the world, offering **precision, quality** and a distinctive **longer lifetime** in all thermoformed packaging applications.

### CUSTOMIZED CONVEYOR CHAINS

iwis conveyor chains can be customized to meet the **specific requirements** of your application. iwis not only offers a wide range of **special straight and bent attachment plates**, we can also help customers develop their own special designs.

### HIGHLIGHTS

- 1 Specially designed **guide rollers** and wear resistant extruded **pins** offer precise film alignment.
- 2 SL (super longlife) heat-treated, **easy break pins** increase wearlife and precision of operation.
- 3 Uniquely designed and specially hardened **spike profiles** offer the best solution for handling your Thermoform material and optimises the lifetime of the chain.
- 4 Specially designed **intermediate plates** reduce lateral forces within the chain, thus reducing elongation while extending wear life.

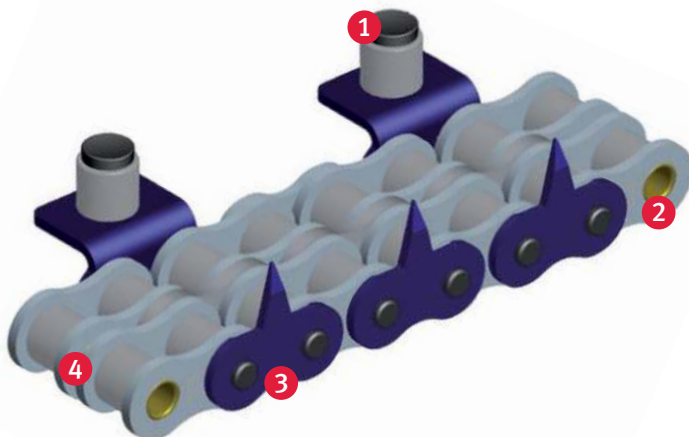



ISO	iwis reference	P (°)	Pitch		Ave. tensile strength $F_b$ (N)	Min. tensile strength $F_u$ (N)	Bearing area $f$ (cm <sup>2</sup> )	Weight /m $q$ (kg/m)	Inner link			Outer link			Transverse pitch $e$ (mm)
			$p$ (mm)						$b_1$ (mm) min.	$b_2$ (mm) max.	$g$ (mm) max.	$a_1$ (mm) max.	$a$ (mm) max.	Roller $d_1$ (mm) max.	
<b>Available Standard Roller Chains</b>															
08 B-1	L 85 SL	1/2 x 5/16	12.7	22.000	17.800	0.5	0.7	7.75	11.3	11.8	16.9	18.5	8.51	4.45	-
08 B-2	D 85 SL	1/2	12.7	40.000	31.100	1	1.4	7.75	11.3	11.8	30.8	32.4	8.51	4.45	13.92

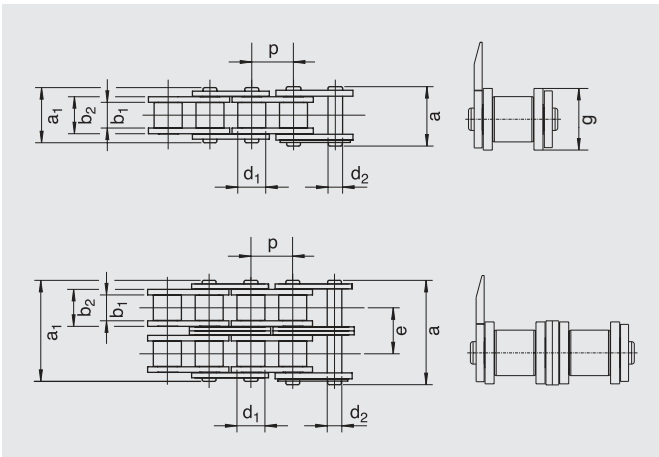

**EXAMPLES OF AVAILABLE SPECIAL IWIS STRAIGHT ATTACHMENTS PLATES**

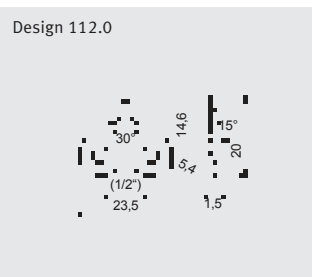

FL85SL with 112.0:  
**Art. 50002138**

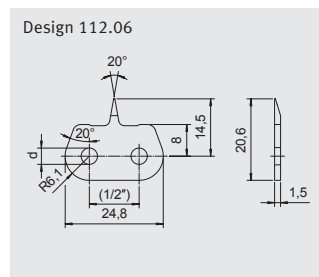

FD85SL with 112.06:  
**Art. 50019757**

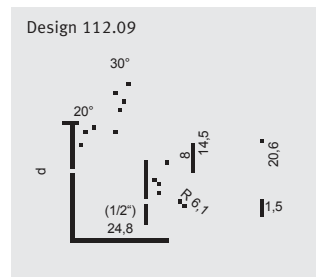

FD85SL with 112.09:  
**Art. 50028230**

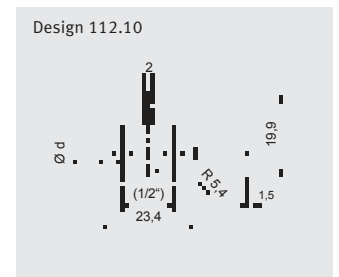

Various designs available.

**FURTHER PRODUCT BENEFITS**

- Special lubrications available
- Reduced length tolerances
- Special chain solutions on request (e.g. with or without guide rollers)
- Also MEGAlife maintenance-free, ANSI and side bow versions available

## **iwis® Conveyor Chains with bent attachment plates** based on iwis chains complying with ISO 606 and ISO 1275

ISO	iwis reference	Pitch				Simplex		Duplex		Triplex			Threaded insert					
		p (°)	p (mm)	c (mm)	d (mm)	e <sub>1</sub> (mm)	f <sub>1</sub> (mm)	e <sub>2</sub> (mm)	f <sub>2</sub> (mm)	e <sub>3</sub> (mm)	f <sub>3</sub> (mm)	g (mm)	h (mm)	i (mm)	l (mm)	s (mm)	M (mm)	m max. (mm)
<b>Design 202.1</b>																		
-	P 83 V	1/2	12.7	8.0	4.2	24.1	36.1	-	-	-	-	4.5	14.0	-	18.1	1.5	-	-
-	S 84 V	1/2	12.7	8.0	4.2	25.8	37.8	-	-	-	-	4.5	14.0	-	18.1	1.5	-	-
08 B-1	L 85 SL <sup>1)</sup>	1/2	12.7	8.0	4.2	27.6	39.6	41.5	53.5	55.4	67.4	5.4	14.0	-	18.1	1.5	4	5.2
10 B-1	M 106 SL <sup>1)</sup>	5/8	15.875	9.0	5.2	33.6	49.6	50.1	66.1	66.6	82.6	6.8	18.0	-	24.0	1.6	5	5.3
12 B-1	M 127 SL <sup>1)</sup>	3/4	19.05	10.0	6.2	41.1	61.1	60.5	80.5	79.9	99.9	7.4	22.6	-	28.0	1.8	5	5.5
16 B-1	M 1611 <sup>1) 2)</sup>	1	25.4	16.0	8.2	53.9	77.9	85.8	109.8	117.7	141.7	10.4	26.0	-	36.2	3.0	6	8.2
08 A-1 ANSI 40	L 85 A <sup>1)</sup>	1/2	12.7	8.0	4.2	27.4	39.4	41.8	53.8	56.2	68.2	4.5	14.0	-	18.1	1.5	-	-
10 A-1 ANSI 50	M 106 A <sup>1)</sup>	5/8	15.875	9.0	5.2	34.1	50.1	52.3	68.3	70.4	86.4	6.8	18.0	-	24.0	1.6	-	-
12 A-1 ANSI 60	M 128 A SL <sup>1)</sup>	3/4	19.05	13.0	6.2	38.9	58.9	61.6	81.6	84.4	104.4	7.4	20.4	-	28.0	2.4	-	-
16 A-1 ANSI 80	M 1610 A <sup>1) 2)</sup>	1	25.4	16.0	8.2	51.0	75.0	80.2	104.2	109.5	133.5	10.4	26.0	-	36.2	3.0	-	-
<b>Design 203.1 and 203.2</b>																		
-	P 83 V <sup>2)</sup>	1/2	12.7	9.5	4.2	29.1	41.1	-	-	-	-	4.5	16.5	12.7	23.6	1.5	-	-
-	S 84 V <sup>2)</sup>	1/2	12.7	9.5	4.2	30.8	42.8	-	-	-	-	4.5	16.5	12.7	23.6	1.5	-	-
08 B-1	L 85 SL <sup>1) 2)</sup>	1/2	12.7	9.5	4.2	32.6	44.6	46.5	58.5	60.4	72.4	5.4	16.5	12.7	23.6	1.5	4	5.2
10 B-1	M 106 SL <sup>1) 2)</sup>	5/8	15.875	11.0	5.2	30.6	49.6	47.1	66.1	63.6	82.6	7.5	18.0	15.8	31.0	1.6	5	5.3
12 B-1	M 127 SL <sup>1) 2)</sup>	3/4	19.05	12.0	6.2	35.5	56.9	54.9	76.3	74.3	95.7	9.0	20.5	19.0	37.2	1.8	5	5.5
16 B-1	M 1611 <sup>1) 2)</sup>	1	25.4	18.0	8.2	57.7	83.9	89.6	115.8	121.5	147.8	10.4	29.0	25.4	47.2	3.0	6	8.2
08 A-1 ANSI 40	L 85 A <sup>1) 2)</sup>	1/2	12.7	9.5	4.2	32.4	44.4	46.8	58.8	61.2	73.2	4.5	16.5	12.7	23.6	1.5	-	-
10 A-1 ANSI 50	M 106 A <sup>1) 2)</sup>	5/8	15.875	11.0	5.2	31.1	50.1	49.3	68.3	67.3	86.4	7.5	18.0	15.8	31.0	1.6	-	-
12 A-1 ANSI 60	M 128 A SL <sup>1) 2)</sup>	3/4	19.05	13.0	6.2	37.3	58.7	60.0	81.4	82.8	104.2	9.0	20.3	19.0	37.2	2.4	-	-
16 A-1 ANSI 80	M 1610 A <sup>1) 2)</sup>	1	25.4	18.0	8.2	54.8	81.0	84.0	110.2	113.3	139.5	10.4	29.0	25.4	47.2	3.0	-	-
<b>Design 201.1 and 201.2</b>																		
208 B	LR 165 SL <sup>2)</sup>	1	25.4	10.0	4.2	26.2	38.6	-	-	-	-	6.5	13.5	14.0	24.2	1.5	-	-
210 B	LR 206 SL <sup>2)</sup>	1 1/4	31.75	11.0	5.2	30.6	49.6	-	-	-	-	7.5	18.0	18.0	30.2	1.6	-	-
212 B	LR 247 SL <sup>2)</sup>	1 1/2	38.1	13.0	6.2	34.9	55.5	-	-	-	-	9.0	19.8	20.0	36.2	1.7	-	-
216 B	LR 3211 <sup>2)</sup>	2	50.8	18.0	8.2	57.7	81.9	-	-	-	-	10.2	28.0	28.0	48.2	3.0	-	-

<sup>1)</sup> Available also for corresponding double and triple strand chains <sup>2)</sup> The bent attachment plates can also be fitted facing inwards with the top part

## **iwis**® Conveyor Chains with bent attachment plates based on iwis chains complying with ISO 606 and ISO 1275

### BENT ATTACHMENT PLATES

The designs shown below can be supplied as connecting links, or outer links for end fitting or repair.

When the attachment is fitted facing inwards over the chain, threaded inserts

cannot be used. Further threaded inserts can also be supplied. Details on request.

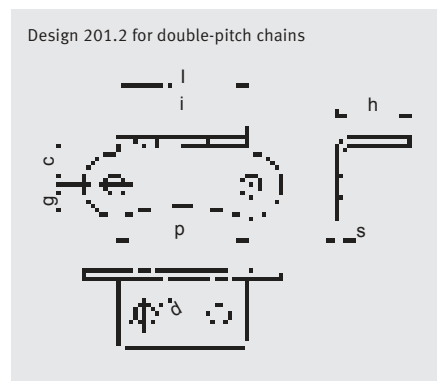
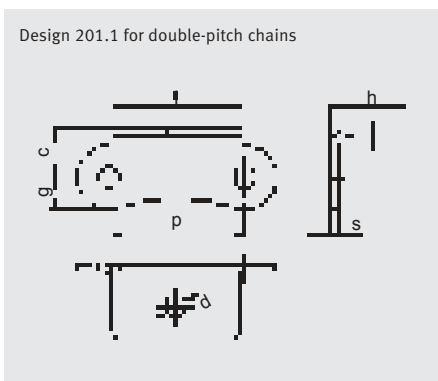
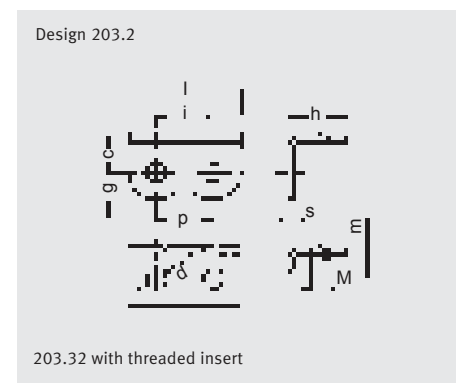
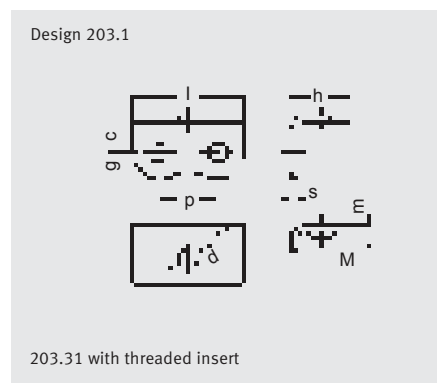
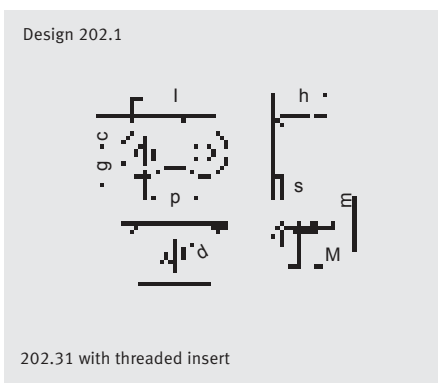
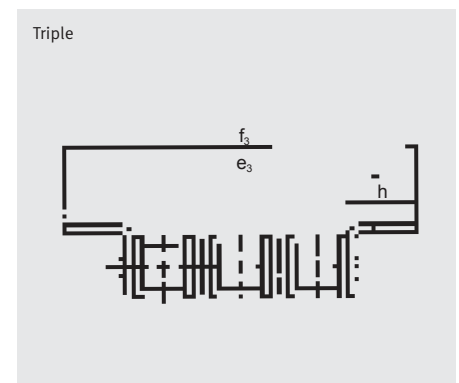
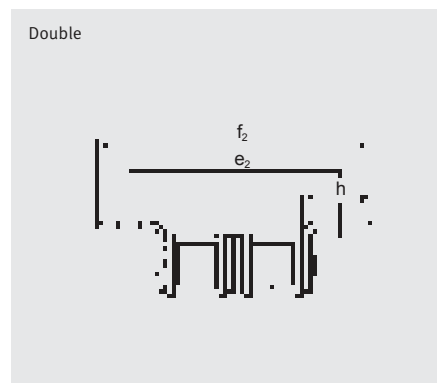
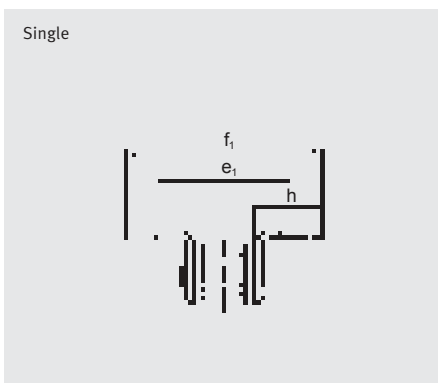

## **iwis**® Conveyor Chains

### Special straight attachment plates – various examples

For chain G 52: Design 103.7

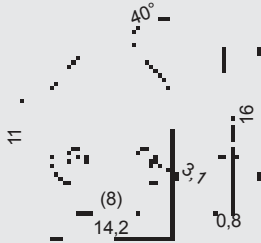

For chain G 52: Design 121.0

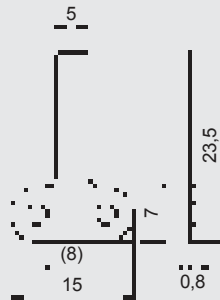

For chain L 85 SL: Design 103.62



For chain L 85 SL: Design 103.63

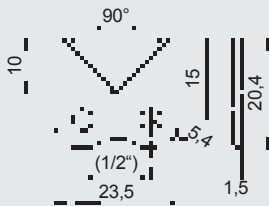

For chain L 85 SL: Design 103.65

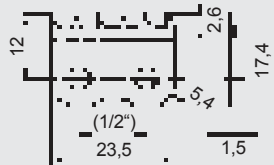

For chain L 85 SL: Design 106.0  
Guide plates for inner links

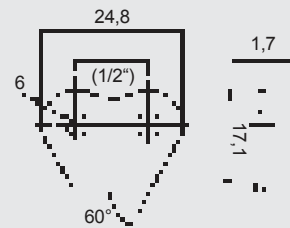

For chain L 85 SL: Design 110.0

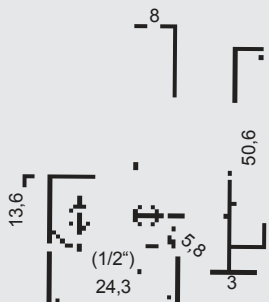

For chain L 85 SL: Design 112.0



For chain L 85 SL: Design 120.11

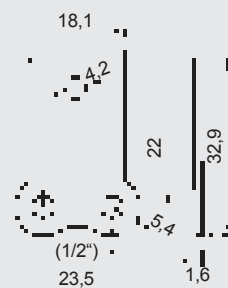

For chain L 85 SL: Trip or cam plate

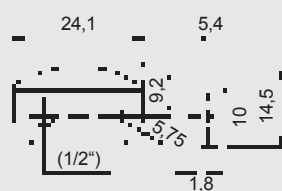

For chain M 106 SL: Design 102.71

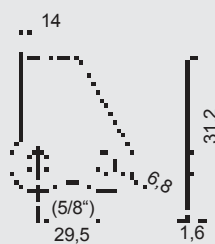

For chain M 127 SL: Design 102.61

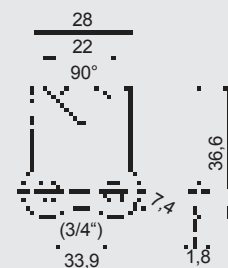

## **iwis**® Conveyor Chains

### Special straight attachment plates – various examples

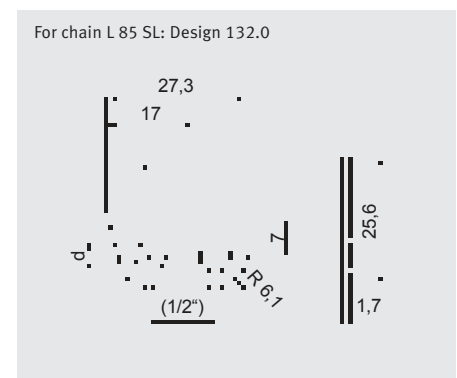
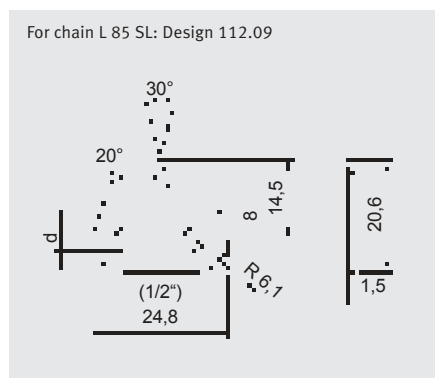
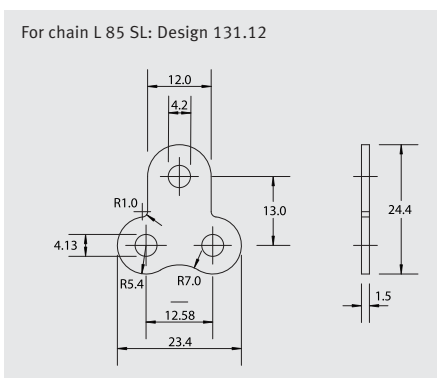
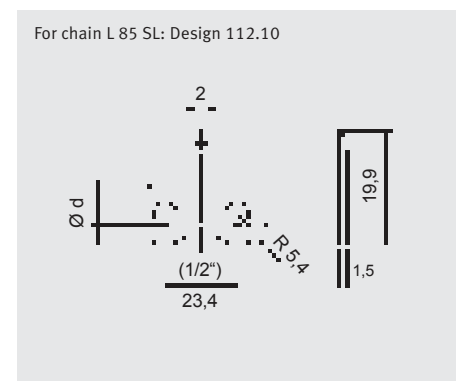
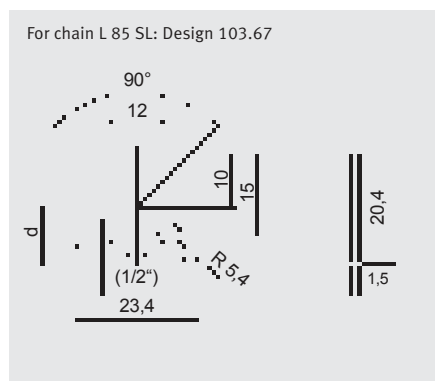
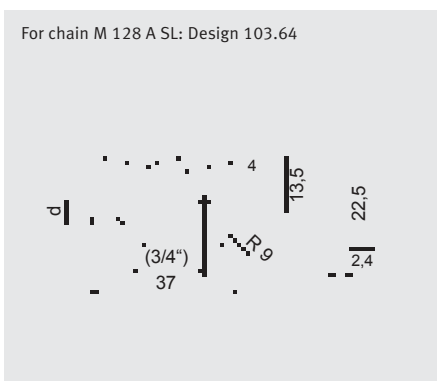
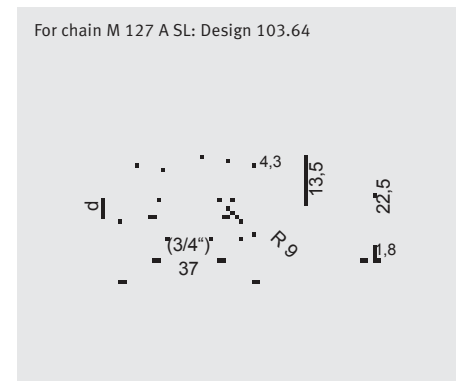
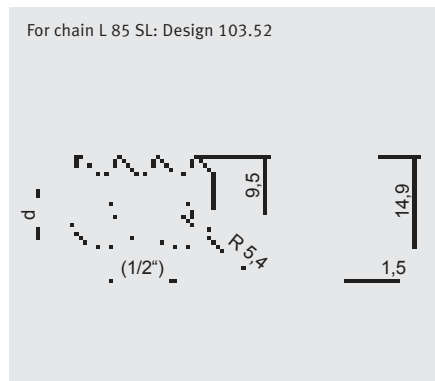
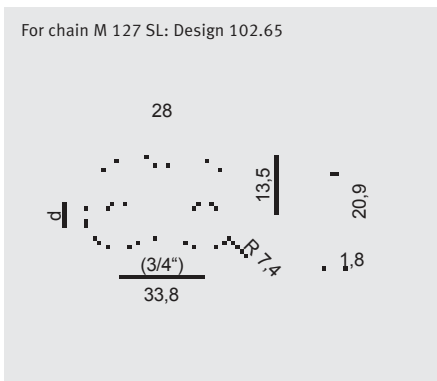
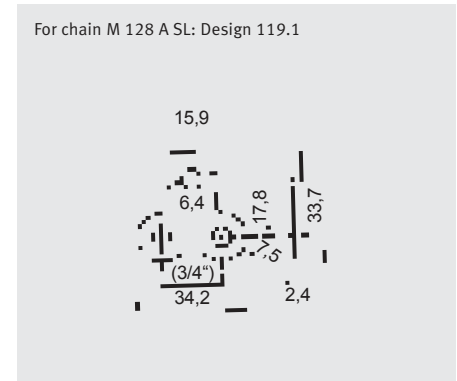
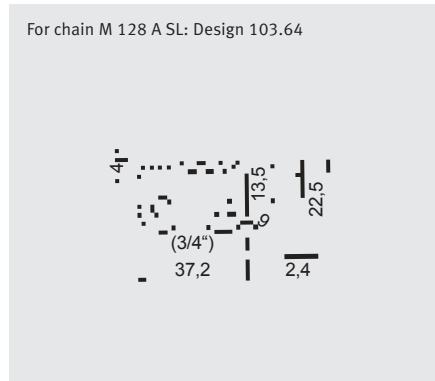
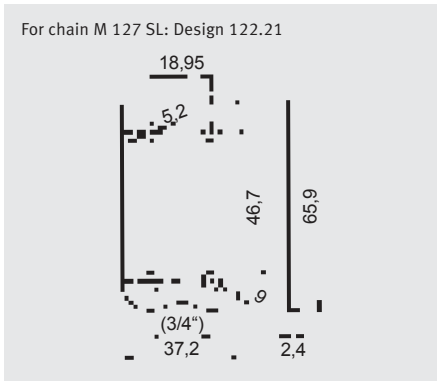

## iwis® Conveyor Chains

### Special bent attachment plates – various examples

For chain L 85 SL: Design 203.8

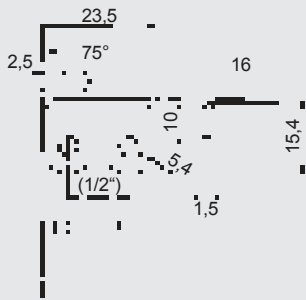

For chain L 85 SL: Design 220.11

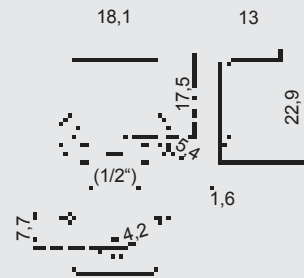

For chain M 106 SL: Design 220.13

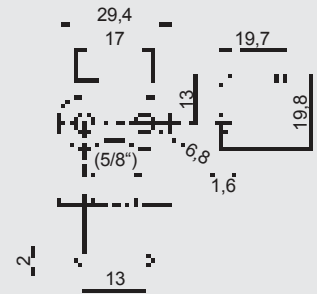

For chain M 106 SL: Design 202.6

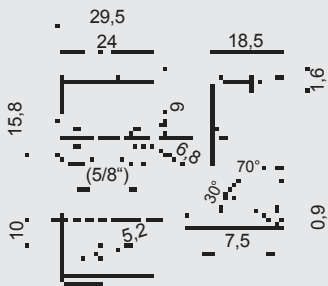

For chain M 127 SL: Design 203.8

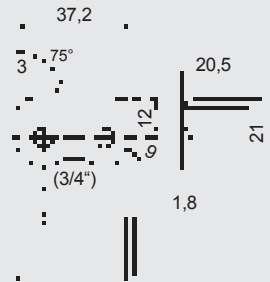

For chains M 128 A SL/M 128 A SB, Design 222.2

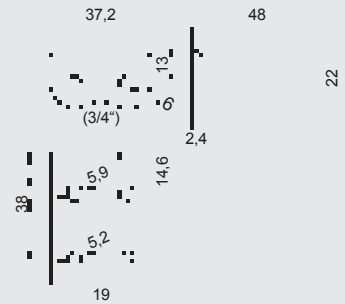

For chain M 128 A SL: Design 202.3

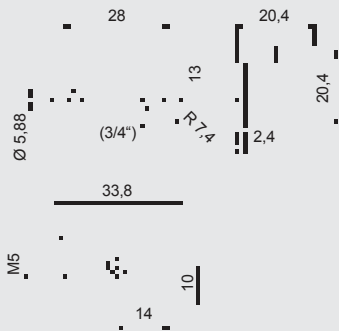

For chain M 128 A SL: Design 202.8



For chains M 1610 A and M 1611 SL: Design 202.13

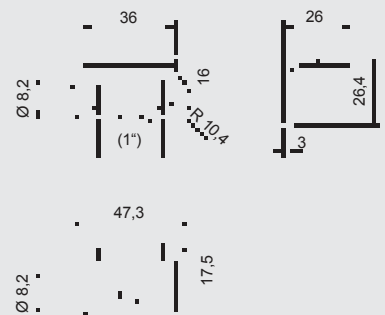

For chain M 127 SL: Design 203.12

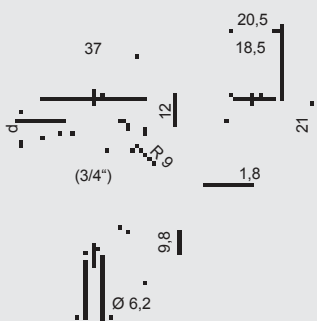

For chain P83V: Design 220.15

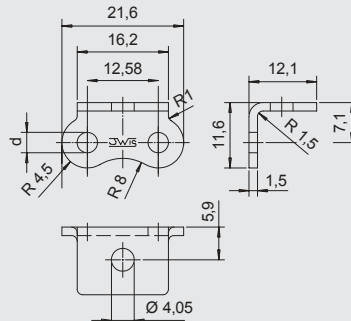

Similar attachment plate designs for other chain types are available on request, as are other attachment plate designs. For some special attachment plates minimum order quantities are required.

## **iwis® Conveyor Chains with extended bearing pins** based on iwis chains complying with ISO 606 and ISO 1275

ISO	iwis reference <sup>1)</sup>	Pitch P (°)	Pitch P (mm)	Inner width b <sub>1</sub> (mm)	Roller diameter d <sub>1</sub> (mm)	Extended bearing pin diameter d <sub>2</sub> (mm)	Design A pin length		Design B and C pin length			
							L <sub>1</sub> (mm)	l <sub>1</sub> (mm)	L <sub>2</sub> (mm)	l <sub>2</sub> (mm)	l <sub>3</sub> (mm)	
<b>Pin design A, B, C</b>												
05 B-1	G 52	-	8.0	3.16	5.0	2.31	17.5	10.0	27.5	20.0	10.5	
06 B-1	G 67	3/8	9.525	5.72	6.35	3.31	22.0	10.0	34.0	22.0	11.5	
-	P 83 V	1/2	12.7	4.88	7.75	3.68	22.0	10.0	37.0	25.0	13.0	
08 B-1	L 85 SL	1/2	12.7	7.75	8.51	4.45	25.5	10.0	40.5	25.0	13.0	
10 B-1	M 106 SL	5/8	15.875	9.65	10.16	5.08	30.0	12.0	48.0	30.0	15.5	
12 B-1	M 127 SL	3/4	19.05	11.75	12.07	5.72	36.0	15.0	51.0	30.0	15.5	
16 B-1	M 1611	1	25.4	17.02	15.88	8.28	53.5	20.0	68.5	35.0	18.0	
08 A-1 ANSI 40	L 85 A	1/2	12.7	7.94	7.95	3.96	25.5	10.0	45.3	30.0	15.5	
10 A-1 ANSI 50	M 106 A	5/8	15.875	9.53	10.16	5.08	31.5	12.0	48.0	29.0	15.0	
12 A-1 ANSI 60	M 128 A SL	3/4	19.05	12.70	11.91	5.96	38.0	14.0	48.0	24.0	12.5	
16 A-1 ANSI 80	M 1610 A	1	25.4	15.88	15.88	7.92	49.5	19.0	61.3	31.0	16.0	
208 B	LR 165 SL	1	25.4	7.75	8.51	4.45	25.5	10.0	40.5	25.0	13.0	
210 B	LR 206 SL	1 1/4	31.75	9.65	10.16	5.08	30.0	12.0	48.0	30.0	15.5	
212 B	LR 247 SL	1 1/2	38.1	11.75	12.07	5.72	36.0	15.0	51.0	30.0	15.5	
216 B	LR 3211	2	50.8	17.02	15.88	8.28	53.5	20.0	68.5	35.0	18.0	

<sup>1)</sup> For multiple strand chains on request. Other pin designs and lengths available on request.

### EXTENDED BEARING PINS

The designs shown below can be supplied as connecting links or outer links for end fitting or repair (C only as outer link).

Design A

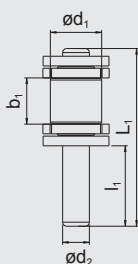

Design B

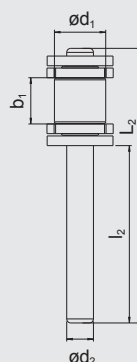

Design C

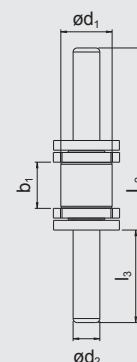

## **iwis® Multiple strand connecting links** for fitting components <sup>1)</sup>

ISO	iwis reference	P (°)	Pitch Pitch of holes in component t (mm)	Inner width b <sub>1</sub> (mm)	Roller diameter d <sub>1</sub> (mm)	Pin diameter d <sub>2</sub> (mm)	Outside width a <sub>2</sub> (mm)	a <sub>3</sub> (mm)	A <sub>2</sub> (max. mm)	A <sub>3</sub> (max. mm)	
<b>Duplex</b>											
05B-1	G 52	8 mm	7.94	3.16	5.0	2.31	14.9	-	4.0	-	
06B-1	G 67	3/8	9.42	5.72	6.35	3.31	24.5	34.6	7.0	17.5	
<b>Duplex / Triplex</b>											
08B-1	L 85 SL	1/2	12.58	7.75	8.51	4.45	32.3	46.2	11.3	25.2	
10B-1	M 106 SL	5/8	15.76	9.65	10.16	5.08	37.4	53.9	13.3	29.9	
12B-1	M 127 SL	3/4	18.95	11.75	12.07	5.72	42.9	62.4	15.6	35.1	
16B-1	M 1611	1	25.27	17.02	15.88	8.28	68.7	100.6	25.5	57.4	
08 A-1 ANSI 40	L 85 A	1/2	12.58	7.94	7.95	3.96	31.8	46.2	11.2	25.5	
10 A-1 ANSI 50	M 106 A	5/8	15.76	9.53	10.16	5.08	39.8	57.9	13.8	32.0	
12 A-1 ANSI 60	M 128 A SL	3/4	18.95	12.70	11.91	5.96	49.4	72.2	17.8	40.6	
16 A-1 ANSI 80	M 1610 A	1	25.27	15.88	15.88	7.92	63.2	92.6	22.6	51.9	

<sup>1)</sup> Please note the exact pitch measure „p“ for the assembly of special components.

### EXAMPLES

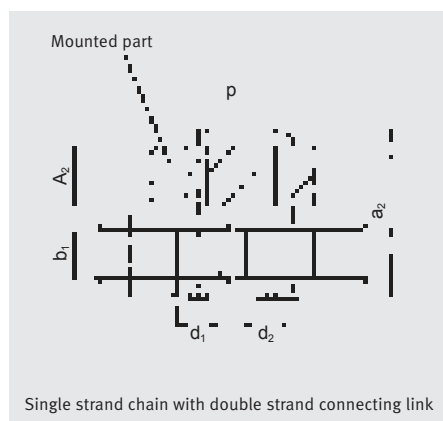

Multiple strand connecting links permit components to be fitted easily at specific locations on the chain.

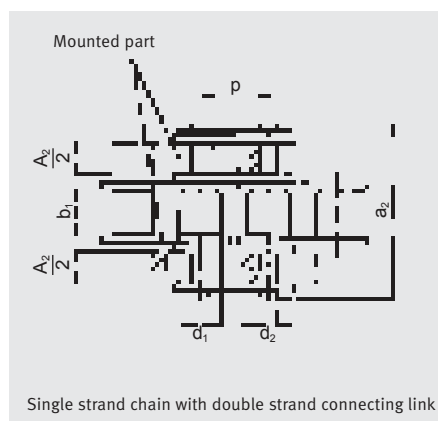

Multiple strand connecting links can be supplied with normal side plates or as connecting links with straight or bent attachment plates, mounted on one or both sides.

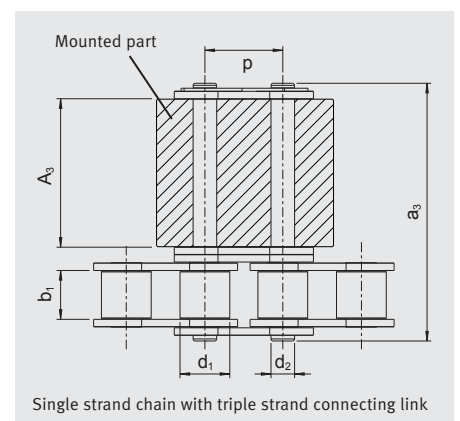

Note: The pitch of holes in the mounted part (component) differ from chain pitch.



## **iwis**® Conveyor Chains with U-shaped attachments based on iwis chains complying with ISO 606

ISO	iwis reference	Pitch P (mm)	A (mm)	B (mm)	a (mm)	c (mm)	d (mm)	g (mm)	h (mm)	i (mm)	k (mm)	l (mm)	s (mm)	M (mm)	Threaded insert m max. (mm)
<b>U-shaped attachment 303.2 / 303.32 / 303.9</b>															
08B-1	L 85 SL	12.7	17.8	19.8	21.5	9.5	4.1	6.3	14.6	12.6	3.0	24.2	1.5	4	5.2
08B-2	D 85 SL	12.7	31.8	33.9	35.5	9.5	4.1	6.3	28.5	13.9	3.0	24.2	1.5	4	5.2
10B-1	M 106 SL	15.875	20.0	22.0	24.0	12.0	4.73	7.5	16.6	15.8	3.0	31.0	1.5	5	5.2
16 A-1 ANSI 80	M 1610 A	25.4	33.7	36.5	38.4	16.2	8.7	10.5	27.3	25.3	5.0	49.2	2.1	6	7.3



### Chain width:

When U-shaped attachments are fitted between the inner and outer plates, the chain width increases above the norm.  
a = pin length of connecting link

Design 303.2 with standard attachment holes

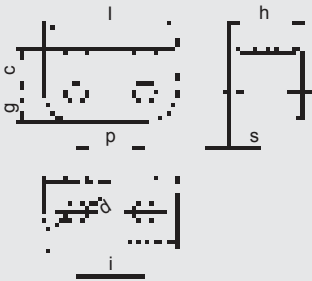

Design 303.32 with threaded inserts

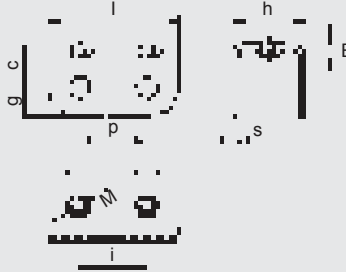

With D 85 SL threaded inserts are positioned transversely to the chain

Design 303.9 with rubber cover

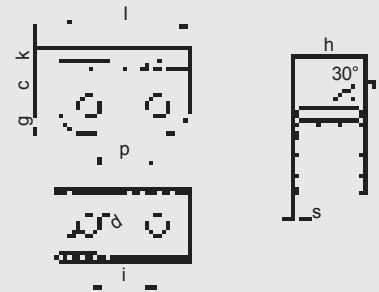

Cover material: Perbunan  
Hardness: 65 Shore / Temperature: -30 up to +100 °C

## SPECIAL DESIGNS

1"-double strand chain with special U-shaped attachment. Base chain: iwis M 1610 A

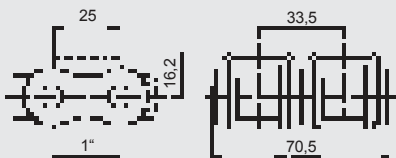

Design 303.94 for chain D 85 SL

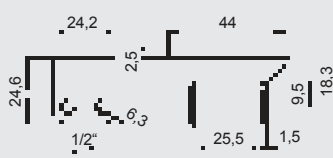

Design 303.97 for chain L 85 SL

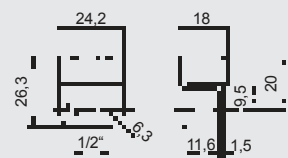



# JWIS<sup>®</sup> Rapid Service for Conveyor Chains

The new Rapid Service from iwis: the fast, flexible conveyor chain range for delivery of selected chain types at short notice. MEGAlife maintenance-free versions also available. Conveyor chains with customer-specific special attachments can now also be produced in small quantities quickly and at short notice without compromising the accustomed high JWIS quality standards! Only iwis can offer this.



## JWIS® Rapid Service for Conveyor Chains

**NEW**  
by iwis



### Express production for fast-track chains

#### RAPID SERVICE

iwis has set up new production lines to offer you more flexibility when you need roller chains with attachments at short notice.

The new production lines enable us to offer extra-short lead times and a high level of flexibility for small quantities of standard roller chains with bent or straight attachment plates and roller chains with elongated pins. All Rapid Service articles are also available in MEGAlife maintenance-free versions.

#### HIGHLIGHTS

- **Fastest delivery times**
- **Highest flexibility** for our rapid service conveyor chains program
- **Chains types:** conveyor chains with straight and bent attachment plate, as well as conveyor chains with extended bearing pins
- Delivery scope: chain sizes **08B-1 to 16B-1**
- **MEGAlife maintenance-free versions** also available
- All attachments are **nickel-plated**
- Delivery time for standard versions: **at short notice following request**

#### EXKLUSIVE

**Conveyor chains with customer-specific special attachments** can now also be produced in small quantities quickly and at short notice without compromising the accustomed high JWIS quality standards!

**Only iwis can offer this.**

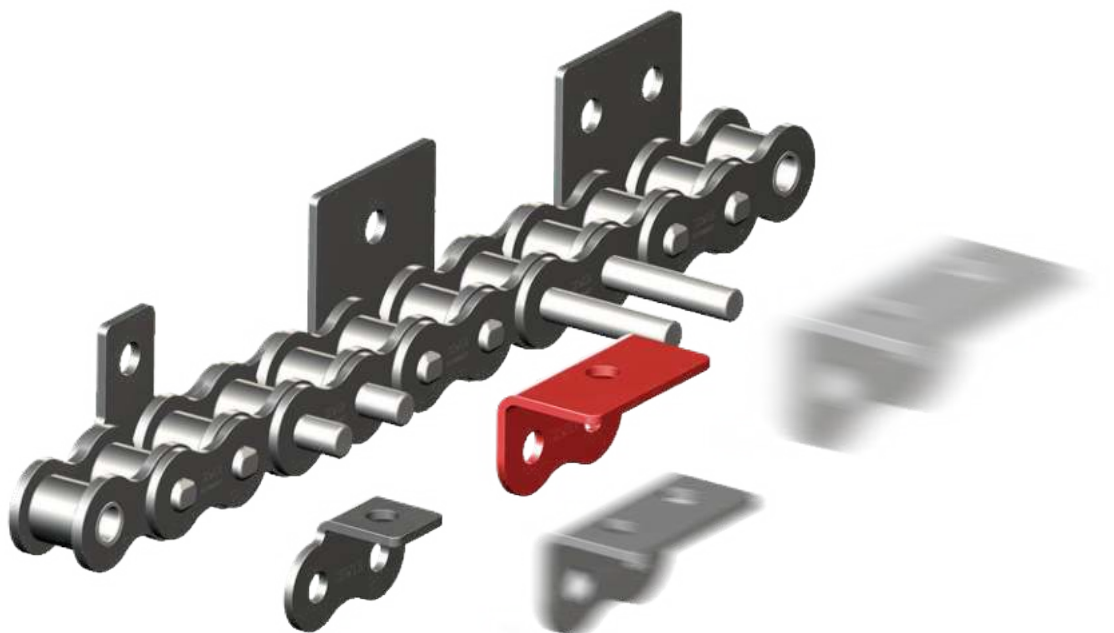

## **iwis® Conveyor Chains with straight attachment plates** based on iwis chains complying with ISO 606

ISO	iwis reference	MEGAlife version	p (°)	Pitch				Single strand chains e <sub>1</sub> (mm)	Double strand chains e <sub>2</sub> (mm)	Triple strand chains e <sub>3</sub> (mm)	g (mm)	i (mm)	l (mm)	s (mm)	M (mm)	Threaded insert	
				p (mm)	a (mm)	b (mm)	d (mm)									m	m max (mm)
<b>Plate No. 102.1</b>																	
08 B-1	L 85 SL	L 85 <b>ML</b>	1/2	12.7	13.0	19.0	4.2	11.6	25.5	39.4	5.4	-	18.0	1.5	4	5.2	
10 B-1	M 106 SL	M 106 <b>ML</b>	5/8	15.875	16.3	24.3	5.2	13.6	30.1	46.6	6.8	-	24.0	1.6	5	5.3	
12 B-1	M 127 SL	M 127 <b>ML</b>	3/4	19.05	19.1	29.1	6.2	15.9	35.3	54.7	7.4	-	28.0	1.8	5	5.5	
16 B-1	M 1611	M 1611 <b>ML</b>	1	25.4	24.6	36.6	8.2	25.9	57.8	89.7	10.4	-	36.2	3.0	6	8.2	
<b>Plate No. 103.2</b>																	
08 B-1	L 85 SL	L 85 <b>ML</b>	1/2	12.7	17.0	23.0	4.2	11.6	25.5	39.4	5.4	12.7	23.6	1.5	4	5.2	
10 B-1	M 106 SL	M 106 <b>ML</b>	5/8	15.875	16.3	25.8	5.2	13.6	30.1	46.6	7.5	15.8	31.0	1.6	5	5.3	
12 B-1	M 127 SL	M 127 <b>ML</b>	3/4	19.05	18.3	29.0	6.2	15.9	35.3	54.7	9.0	19.0	37.2	1.8	5	5.5	
16 B-1	M 1611	M 1611 <b>ML</b>	1	25.4	28.45	41.55	8.2	25.9	57.8	89.7	10.35	25.4	47.2	3.0	6	8.2	

The suffix SL (Super Longlife) indicates chains with particularly wear-resistant pins.

All types available as maintenance-free  
**MEGAlife** version.

[www.iwis.de/MEGAlife](http://www.iwis.de/MEGAlife)



Design 102.1

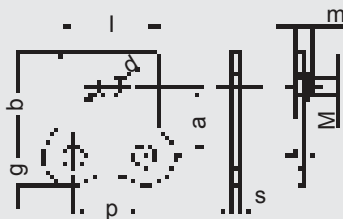

Design 103.2

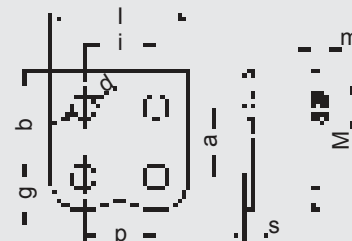

## iwis® Conveyor Chains with bent attachment plates based on iwis chains complying with ISO 606

ISO	iwis reference	MEGALife version	p (°)	Pitch			Single strand chains			Double strand chains			Triple strand chains			h (mm)	i (mm)	l (mm)	s (mm)	M (mm)	m max. (mm)	Threaded insert
				p (mm)	c (mm)	d (mm)	e <sub>1</sub> (mm)	f <sub>1</sub> (mm)	e <sub>2</sub> (mm)	f <sub>2</sub> (mm)	e <sub>3</sub> (mm)	f <sub>3</sub> (mm)	g (mm)									
<b>Plate No. 202.1</b>																						
08 B-1	L 85 SL	L 85 <b>ML</b>	1/2	12.7	8.0	4.2	27.6	39.6	41.5	53.5	55.4	67.4	5.4	14.0	-	18.1	1.5	4	5.2			
10 B-1	M 106 SL	M 106 <b>ML</b>	5/8	15.875	9.0	5.2	33.6	49.6	50.1	66.1	66.6	82.6	6.8	18.0	-	24.0	1.6	5	5.3			
12 B-1	M 127 SL	M 127 <b>ML</b>	3/4	19.05	10.0	6.2	41.1	61.1	60.5	80.5	79.9	99.9	7.4	22.6	-	28.0	1.8	5	5.5			
16 B-1	M 1611	M 1611 <b>ML</b>	1	25.4	16.0	8.2	53.9	77.9	85.8	109.8	117.7	141.7	10.4	26.0	-	36.2	3.0	6	8.2			
<b>Plate No. 203.1</b>																						
08 B-1	L 85 SL	L 85 <b>ML</b>	1/2	12.7	9.5	4.2	32.6	44.6	46.5	58.5	60.4	72.4	5.4	16.5	12.7	23.6	1.5	4	5.2			
10 B-1	M 106 SL	M 106 <b>ML</b>	5/8	15.875	11.0	5.2	30.6	49.6	47.1	66.1	63.6	82.6	7.5	18.0	15.8	31.0	1.6	5	5.3			
12 B-1	M 127 SL	M 127 <b>ML</b>	3/4	19.05	12.0	6.2	35.5	56.9	54.9	76.3	74.3	95.7	9.0	20.5	19.0	37.2	1.8	5	5.5			
16 B-1	M 1611	M 1611 <b>ML</b>	1	25.4	18.0	8.2	57.7	83.9	89.6	115.8	121.5	147.8	10.4	29.0	25.4	47.2	3.0	6	8.2			
<b>Plate No. 203.1</b>																						
08 B-1	L 85 SL	L 85 <b>ML</b>	1/2	12.7	9.5	4.2	32.6	44.6	46.5	58.5	60.4	72.4	5.4	16.5	12.7	23.6	1.5	4	5.2			
10 B-1	M 106 SL	M 106 <b>ML</b>	5/8	15.875	11.0	5.2	30.6	49.6	47.1	66.1	63.6	82.6	7.5	18.0	15.8	31.0	1.6	5	5.3			
12 B-1	M 127 SL	M 127 <b>ML</b>	3/4	19.05	12.0	6.2	35.5	56.9	54.9	76.3	74.3	95.7	9.0	20.5	19.0	37.2	1.8	5	5.5			
16 B-1	M 1611	M 1611 <b>ML</b>	1	25.4	18.0	8.2	57.7	83.9	89.6	115.8	121.5	147.8	10.4	29.0	25.4	47.2	3.0	6	8.2			

The suffix SL (Super Longlife) indicates chains with particulary wear-resistant pins.

All types available as maintenance-free  
**MEGALife** version.

[www.iwis.de/MEGALife](http://www.iwis.de/MEGALife)



Design 202.1

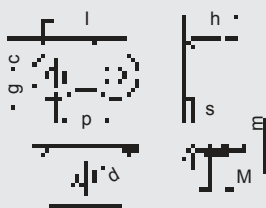

Design 203.1

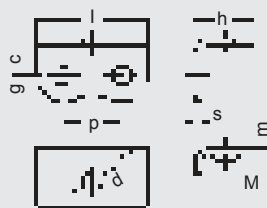

Design 203.2

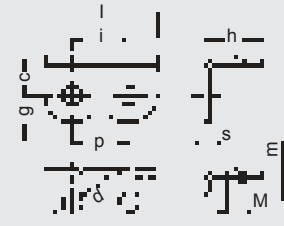

## **iwis**® Conveyor Chains extended bearing pins based on iwis chains complying with ISO 606

ISO	iwis reference	MEGAlife version	p (°)	Pitch				Design A pin length			Design B pin length		
				p (mm)	Inner width b <sub>1</sub> (mm)	Roller diameter d <sub>1</sub> (mm)	Extended bearing pin diameter d <sub>2</sub> (mm)	L <sub>1</sub> (mm)	L <sub>1</sub> (mm)	L <sub>2</sub> (mm)	L <sub>2</sub> (mm)	L <sub>3</sub> (mm)	
<b>Pin design A, B</b>													
08 B-1	L 85 SL	L 85 <b>ML</b>	1/2	12.7	7.75	8.51	4.45	25.5	10.0	40.5	25.0	13.0	
10 B-1	M 106 SL	M 106 <b>ML</b>	5/8	15.875	9.65	10.16	5.08	30.0	12.0	48.0	30.0	15.5	
12 B-1	M 127 SL	M 127 <b>ML</b>	3/4	19.05	11.75	12.07	5.72	36.0	15.0	51.0	30.0	15.5	
16 B-1	M 1611	M 1611 <b>ML</b>	1	25.4	17.02	15.88	8.28	53.5	20.0	68.5	35.0	18.0	

All above chains can alternatively be manufactured with duplex or triplex pins. Delivery time on request.  
The suffix SL indicates chains with particulary wear-resistant pins.

All types available as maintenance-free  
**MEGAlife** version.

[www.iwis.de/MEGAlife](http://www.iwis.de/MEGAlife)



Design A



Design B



# JWTS® MEGAlife

MEGAlife maintenance-free roller and conveyor chains can be applied in all areas where post installation lubrication is not at all or only partly possible. This is the case in clean and dry surroundings or in applications with difficult lubrication passage. MEGAlife maintenance-free chains are corrosion resistant due to nickel-plated parts and can be utilized in a temperature range from  $-40\text{ }^{\circ}\text{C}$  up to  $+150\text{ }^{\circ}\text{C}$ . The chains are supplied either dry or with special-purpose lubrication in line with the requirements of the applied application.







## iwis® MEGAlife I and MEGAlife II

The maintenance-free iwis chains for new conveyor technology

# MORE ADDED VALUE



### STARTING POINT

**MEGAlife** maintenance-free roller chains and conveyor chains can be used in all applications where relubrication is impossible or impractical.

### OUR SOLUTION

MEGAlife maintenance-free roller and conveyor chains offer a **significantly longer service life than conventional low-maintenance/lube-free roller chains.**

#### The benefits for you:

- Less downtime
- Longer replacement intervals for machine and system components
- Significant reduction of maintenance costs

### HIGHLIGHTS MEGALIFE I

- Excellently qualified for normal chain applications without relubrication at speeds amounting to max. 3 m/s
- Permanently maintenance-free under certain conditions
- Easy to dismantle due to easy break
- Applicable in corrosive environments; recommendable with lubrication, if possible
- 100 % compatibility with iwis standard conveyor chains due to the use of original iwis attachments
- MEGAlife conveyor chains with elongated pins are chemically nickel-plated
- All roller chains are mounted with shouldered pins
- Also available as transfer chain TF, power and free conveyor chain SF or grip chain

### HIGHLIGHTS MEGALIFE II

- The solution for fast running chain drives,  $v > 3$  m/s and/or high loads
- Considerably improved wear resistance due to a special thermo-chemical treatment of the pins which influences the hardness of the surface and optimizes herewith the adhesiveness
- Distinctive longer lifetime
- Pins and sintering bushes are optimally adjusted to each other
- Not recommendable in environments susceptible to corrosion
- Mainly applied as drive chain
- For demanding applications

## MORE QUALITY

- 1 Seamless sintered bush made of a material specially developed for this application, hardened and treated to optimize its tribological properties
- 2 Pin with wear-resistant, friction-optimized coating
- 3 Seamless roller with corrosion-resistant coating and geometry optimized on the sinter bush

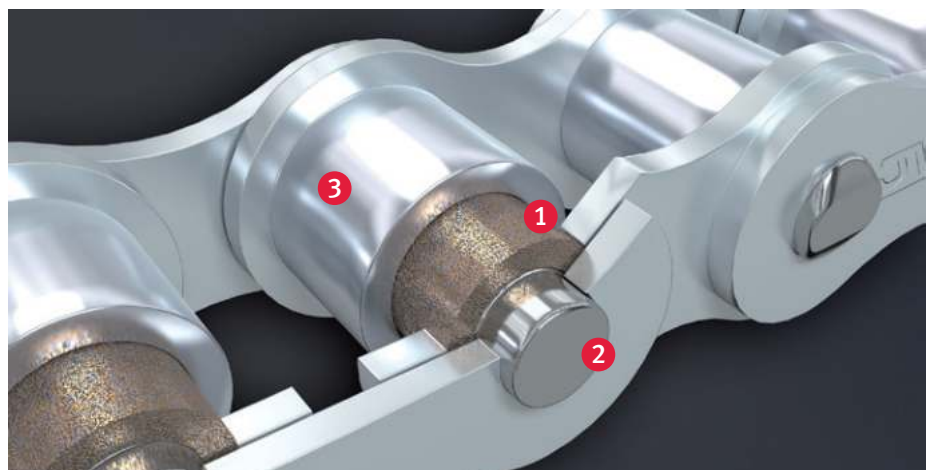



MEGAlife is the benchmark **for extremely high fatigue strength and breaking resistance**, with a proven track record in many practical applications.

**CUSTOMER BENEFITS**

- Extremely high levels of fatigue and breaking strength
- Excellent wear resistance – even at high speeds and loads – where conventional maintenance-free chains stretch
- Protected from corrosion due to nickel-plated parts
- Temperature range from -40 °C up to +150 °C
- It's easy to convert standard chain and conveyor chain applications to MEGAlife: since construction of these chain types follows a modular principle, they are interchangeable and mutually compatible – **no special adaptation required!**
- MEGALIFE chains are clean, dry and environmentally-friendly due to absence of excess lubrication

**AREAS OF APPLICATION**

- Packaging and food industry
  - Printing industry
  - Material handling, conveyor systems
  - Textile and clothing industry
  - Paper manufacture and book binding industry
  - Electronics industry and PCB manufacture
  - Wood, glass and ceramics Industry
  - Medical technology
  - Lamp and lightbulb manufacture
- ... and of course in all areas where relubrication is not at all or only partly possible.

**PRODUCT RANGE**

- Roller chains according to ISO 606
  - Roller chains with different attachments
  - Roller chains with straight side plates
  - Accumulation chains
  - Transfer chains
  - Grip chains
  - Special conveyor chains
- ... almost the entire JWIS chain range can be manufactured in the maintenance-free ML version. Contact us for more details!

**MORE EFFICIENCY**

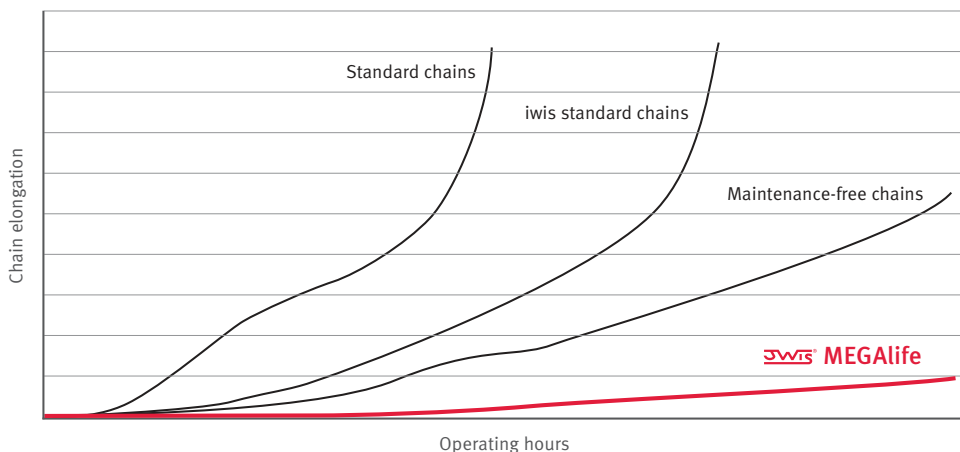

## iwis® MEGAlife I – Roller Chains

based on iwis roller chains complying with ISO 606

ISO	iwis reference	Pitch p (°)	Pitch p (mm)	Ave. tensile strength $F_a$ (N)	Min. tensile strength $F_u$ (N)	Bearing area $F$ (cm <sup>2</sup> )	Weight per m $q$ (kg/m)	$b_1$ (mm) min.	$b_2$ (mm) max.	$g$ (mm) max.	Inner link			Outer link			Article No.
											$a_1$ (mm) max. <sup>1)</sup>	$a$ (mm) max. <sup>1)</sup>	Roller $d_1$ (mm) max.	Pin $d_2$ (mm) max.	Transverse pitch $e$ (mm)		
<b>Simplex</b>																	
06 B-1	G 67 ML*	3/8	9.525	11,000	8,900	0.28	0.41	5.72	8.53	8.20	12.90	14.10	6.35	3.31	–	50033917	
08 B-1	L 85 ML	1/2	12.70	22,000	17,800	0.50	0.70	7.75	11.30	11.80	16.90	18.50	8.51	4.45	–	50026256	
08 A-1 ANSI 40	L 85 AML	1/2	12.70	17,500	13,900	0.44	0.60	7.94	11.15	12.00	16.60	17.50	7.95	3.96	–	50036841	
10 B-1	M 106 ML	5/8	15.875	25,000	22,200	0.67	0.95	9.65	13.28	14.40	19.50	20.90	10.16	5.08	–	50026257	
12 B-1	M 127 ML	3/4	19.05	30,000	28,900	0.89	1.25	11.75	15.62	16.20	22.70	23.60	12.07	5.72	–	50026258	
12 A-1 ANSI 60	M 128 AML	3/4	19.05	41,000	31,300	1.06	1.47	12.70	17.75	18.00	25.30	26.70	11.91	5.96	–	50038464	
16 B-1	M 1611 ML	1	25.4	75,000	60,000	2.10	2.70	17.02	25.45	21.10	36.10	36.90	15.88	8.28	–	50028923	
20 B-1	M 2012 ML	1 1/4	31.75	120,000	95,000	2.92	3.72	19.56	29.1	26.2	41.6	43.3	19.05	10.17	–	50037775	
<b>Duplex</b>																	
06 B-2	D 67 ML	3/8	9.525	19,000	16,900	0.56	0.78	5.72	8.53	8.20	23.40	24.60	6.35	3.31	10.24	50033832	
08 B-2	D 85 ML	1/2	12.70	40,000	31,100	1.00	1.35	7.75	11.30	11.80	30.80	32.40	8.51	4.45	13.92	50027439	
10 B-2	D 106 ML	5/8	15.875	50,000	44,500	1.34	1.85	9.65	13.28	14.40	36.00	37.50	10.16	5.08	16.59	50027509	
12 B-2	D 127 ML	3/4	19.05	60,000	57,800	1.78	2.50	11.75	15.62	16.40	42.10	43.00	12.07	5.72	19.46	50027457	
16 B-2	D 1611 ML	1	25.40	150,000	106,000	4.21	5.40	17.02	29.45	21.10	68.00	68.80	15.85	8.28	31.88	50033161	
20 B-2	D 2012 ML	1 1/4	31.75	210,000	170,000	5.84	7.36	19.56	29.01	25.40	79.70	82.90	19.05	10.19	36.45	50033771	
<b>Triplex</b>																	
08 B-3	TR 85 ML	1/2	12.70	58,000	44,500	1.50	2.00	7.75	11.30	11.80	44.70	46.30	8.51	4.45	13.92	50027510	
10 B-3	TR 106 ML	5/8	15.875	75,000	66,700	2.02	2.80	9.65	13.28	14.40	52.50	54.00	10.16	5.08	16.59	50027511	
12 B-3	TR 127 ML	3/4	19.05	89,000	86,700	2.68	3.80	11.75	15.62	16.40	61.50	62.50	12.07	5.72	19.46	50027512	
16 B-3	TR 1611 ML	1	25.40	219,000	160,000	6.32	8.00	17.02	25.45	21.10	99.20	100.70	15.88	8.28	31.88	50033628	

\* Also available in 10 m length (Art. 50035181), with straight side plates <sup>1)</sup> Differing dimensions for cranked links  
If cranked links are fitted, it should be noted that the breaking strength of the chain may be reduced by approximately 20 %.

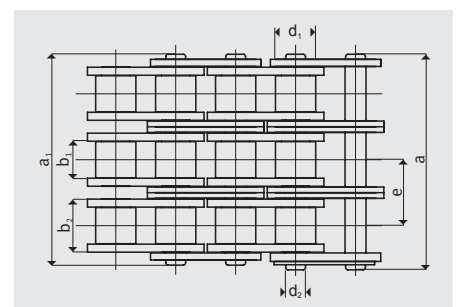
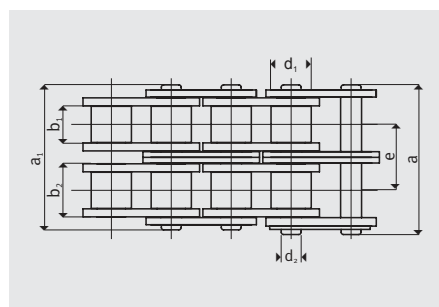
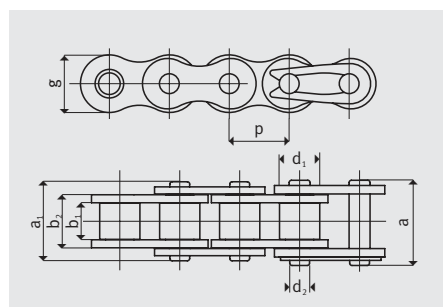

## **iwis**® MEGAlife I – Roller chains with straight side plates based on iwis roller chains complying with ISO 606

ISO	iwis reference	Pitch p (°)	Pitch p (mm)	Ave. tensile strength $F_a$ (N)	Min. tensile strength $F_u$ (N)	Bearing area F (cm²)	Weight per m q (kg/m)	$b_1$ (mm) min.	Inner link $b_2$ (mm) max. $g$ (mm) max.	Outer link $a_1$ (mm) max. <sup>1)</sup> $a$ (mm) max. <sup>1)</sup> Roller $d_1$ (mm) max. Pin $d_2$ (mm) max. Transverse pitch $e$ (mm)	Article No.					
<b>Simplex/Duplex – MEGAlife roller chains with straight side plates</b>																
08B-1	L 85 ML-GL	1/2	12.7	–	17,800	0.5	0.7	7.75	11.3	12.2	16.9	18.5	8.51	4.45	–	50049011
08B-2	D 85 ML-GL	1/2	12.7	–	31,100	1	1.35	7.75	11.3	12.2	30.8	32.4	8.51	4.45	13.92	50046481
10 B-1	M 106 ML-GL	5/8	15.875	24,000	22,200	0.67	0.95	9.65	13.28	13.90	19.50	20.90	10.16	5.08	–	50035304
10 B-2	D 106 ML-GL	5/8	15.875	47,500	44,500	1.34	1.85	9.65	13.28	13.90	36.00	37.50	10.16	5.08	16.59	50034083
12 B-1	M 127 ML-GL	3/4	19.05	30,000	28,900	0.89	1.30	11.75	15.62	16.10	22.70	23.60	12.07	5.72	–	50037351
12 B-2	D 127 ML-GL	3/4	19.05	63,000	57,800	1.78	2.50	11.75	15.62	16.10	42.10	43.00	12.07	5.72	19.46	50034084
16B-1	M 1611 ML-G	1	25.4	77,000	60,000	2.1	2.7	17.02	25.45	20.65	36.1	36.9	15.88	8.28	–	50048583
16B-2	D 1611 ML-GL	1	25.4	151,000	106,000	4.21	5.4	17.02	25.45	20.65	68	68.8	15.88	8.28	31.88	50048584

<sup>1)</sup> Differing dimensions for cranked links If cranked links are fitted, it should be noted that the breaking strength of the chain may be reduced by approximately 20 %.

### HIGHLIGHTS

- Optimum solution for conveyors and transport systems
- Compared to competition products, MEGAlife chains maintain significantly higher rigidity and less wear elongation during their entire service life
- Extremely high availability of conveyor systems, as the customary shutdowns for regular maintenance are no longer necessary
- Guaranteed long service life and cleanliness of conveyor systems in the automotive, logistics and other maintenance-free industries

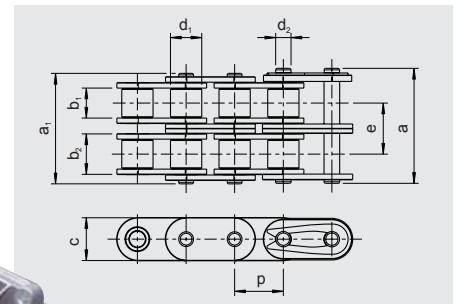
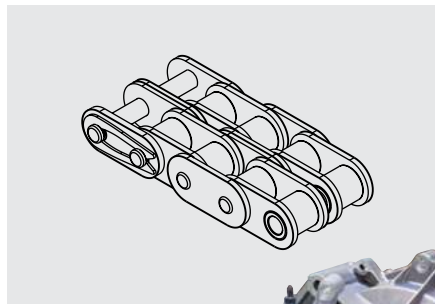
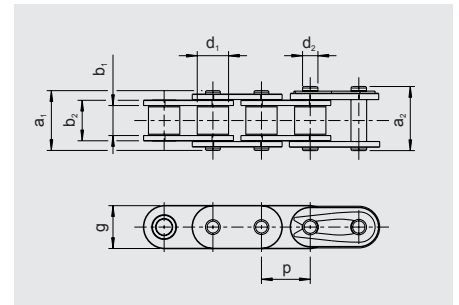
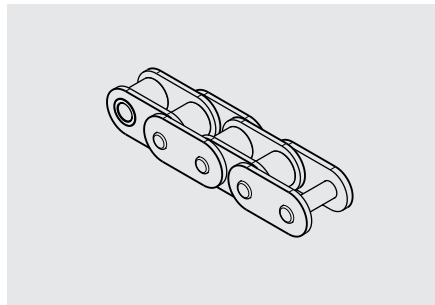

## iwis® MEGAlife I – Conveyor Chains with straight attachment plates based on iwis roller chains complying with ISO 606

ISO	iwis reference	Pitch <sup>2)</sup>		a (mm)	b (mm)	d (mm)	Simplex chains e <sub>1</sub> (mm)	Duplex chains e <sub>2</sub> (mm)	Triplex chains e <sub>3</sub> (mm)	g (mm)	i (mm)	l (mm)	s (mm)	M (mm)	Threaded insert m max. (mm)
		P (°)	P (mm)												
<b>Plate No. 102.1</b>															
08 B-1	L 85 ML <sup>1)</sup>	1/2	12.70	13.0	19.0	4.2	11.6	25.5	39.4	5.4	–	18.0	1.5	4	5.2
10 B-1	M 106 ML <sup>1)</sup>	5/8	15.875	16.3	24.3	5.2	13.6	30.1	46.6	6.8	–	24.0	1.6	5	5.3
12 B-1	M 127 ML <sup>1)</sup>	3/4	19.05	19.1	29.1	6.2	15.9	35.3	54.7	7.4	–	28.0	1.8	5	5.5
16 B-1	M 1611 ML	1	25.40	24.6	36.6	8.2	25.9	57.8	89.7	10.4	–	36.2	3.0	6	8.2
<b>Plate No. 103.1 and 103.2</b>															
08 B-1	L 85 ML <sup>1)</sup>	1/2	12.70	17.0	23.0	4.2	11.6	25.5	39.4	5.4	12.7	23.6	1.5	4	5.2
10 B-1	M 106 ML <sup>1)</sup>	5/8	15.875	16.3	25.8	5.2	13.6	30.1	46.6	7.5	15.8	31.0	1.6	5	5.3
12 B-1	M 127 ML <sup>1)</sup>	3/4	19.05	18.3	29.0	6.2	15.9	35.3	54.7	9.0	19.0	37.2	1.8	5	5.5
16 B-1	M 1611 ML	1	25.40	28.45	41.55	8.2	25.9	57.8	89.7	10.35	25.4	47.2	3.0	6	8.2

<sup>1)</sup> Also for the corresponding duplex and triplex chains <sup>2)</sup> Nominal pitch

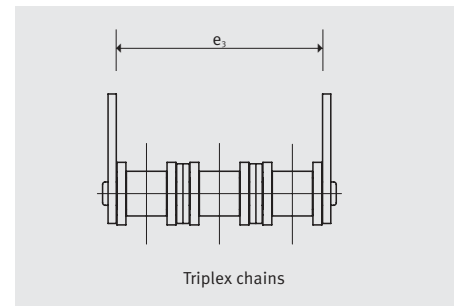
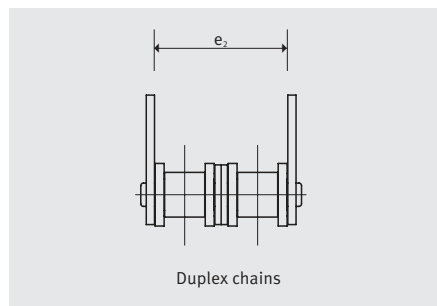
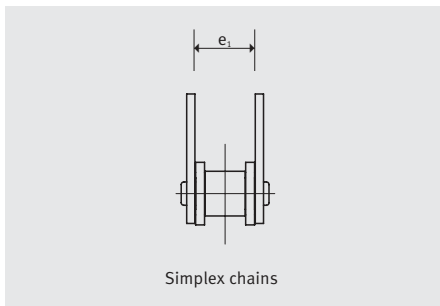

### STRAIGHT ATTACHMENT PLATES

The versions shown are also available as snap-on and outer links for final assembly and repair.

Straight attachments can be fitted on one or both sides of every outer link or at longer intervals.

Additional conveyor chains and threaded inserts on request.

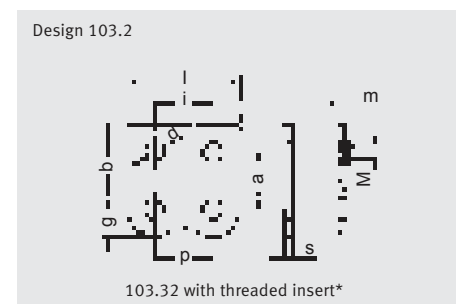
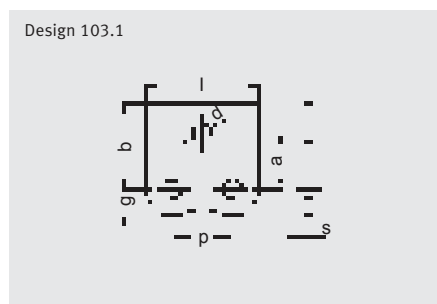
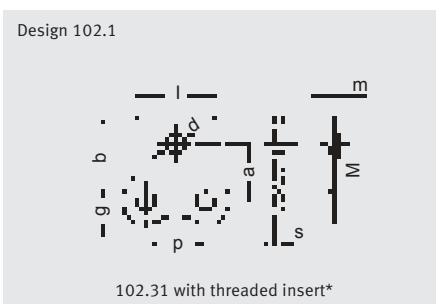

\* Available on request.

## **iwis**® MEGAlife I – Conveyor Chains with bent attachment plates based on iwis roller chains complying with ISO 606

ISO	iwis reference	Pitch <sup>3)</sup>					Simplex chains		Duplex chains		Triplex chains			Threaded insert				
		p (°)	p (mm)	c (mm)	d (mm)	e <sub>1</sub> (mm)	f <sub>1</sub> (mm)	e <sub>2</sub> (mm)	f <sub>2</sub> (mm)	e <sub>3</sub> (mm)	f <sub>3</sub> (mm)	g (mm)	h (mm)	i (mm)	l (mm)	s (mm)	M (mm)	m max. (mm)
<b>Plate No. 202.1</b>																		
08 B-1	L 85 ML <sup>1)</sup>	1/2	12.70	8.0	4.2	27.6	39.6	41.5	53.5	55.4	67.4	5.4	14.0	–	18.1	1.5	4	5.2
10 B-1	M 106 ML <sup>1)</sup>	5/8	15.875	9.0	5.2	33.6	49.6	50.1	66.1	66.6	82.6	6.8	18.0	–	24.0	1.6	5	5.3
12 B-1	M 127 ML <sup>1)</sup>	3/4	19.05	10.0	6.2	41.1	61.1	60.5	80.5	79.9	99.9	7.4	22.6	–	28.0	1.8	5	5.5
16 B-1	M 1611 ML	1	25.40	16.0	8.2	53.9	77.9	85.8	109.8	117.7	141.7	10.4	26.0	–	36.2	3.0	6	8.2
<b>Plate No. 203.1 and 203.2</b>																		
08 B-1	L 85 ML <sup>1) 2)</sup>	1/2	12.70	9.5	4.2	32.6	44.6	46.5	58.5	60.4	72.4	5.4	16.5	12.7	23.6	1.5	4	5.2
10 B-1	M 106 ML <sup>1) 2)</sup>	5/8	15.875	11.0	5.2	30.6	49.6	47.1	66.1	63.6	82.6	7.5	18.0	15.8	31.0	1.6	5	5.3
12 B-1	M 127 ML <sup>1) 2)</sup>	3/4	19.05	12.0	6.2	35.5	56.9	54.9	76.3	74.3	95.7	9.0	20.5	19.0	37.2	1.8	5	5.5
16 B-1	M 1611 ML	1	25.40	18.0	8.2	57.7	83.9	89.6	115.8	121.5	147.8	10.4	29.0	25.4	47.2	3.0	6	8.2

Conveyor chains D 1611 ML and TR 1611 ML on request <sup>1)</sup> Also for corresponding duplex and triplex chains <sup>2)</sup> Assembly of bent attachments also possible inward over the chain except when fitted on both sides to D 85 ML, D 106 ML and D 127 ML <sup>3)</sup> Nominal pitch

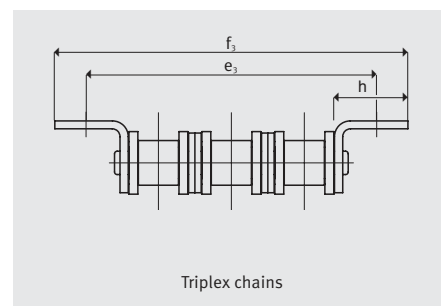
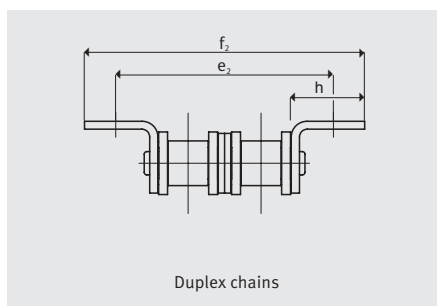
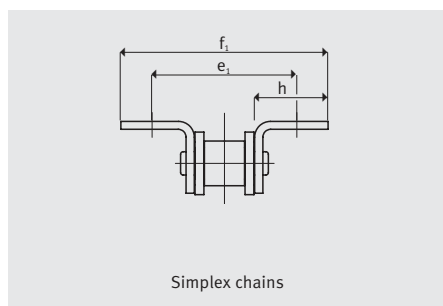

### BENT ATTACHMENTS

The types illustrated are also obtainable for connector and outer link for final assembly and repair. Assembly of the bent attach-

ments with threaded insert over the chain facing inwards is not possible. Fitting bent attachments on one or both sides on each

outer link or at greater spacing is possible. Other conveying chains and threaded inserts on request.

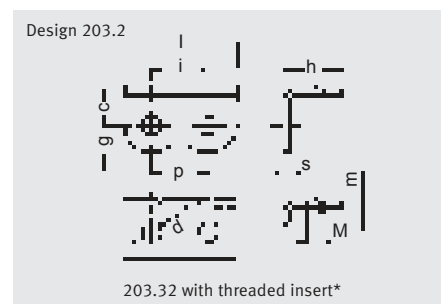
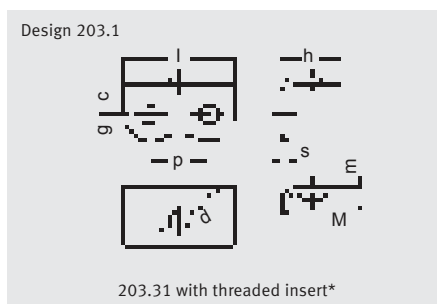
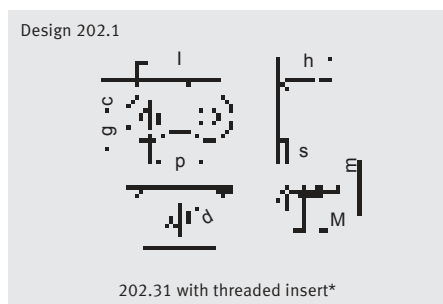

\* Available on request.

## iwis® MEGAlife I – Conveyor Chains with extended pins based on iwis chains complying with ISO 606

ISO	iwis reference <sup>1)</sup>	P (°)	Pitch <sup>2)</sup>		Inner width $b_1$ (mm)	Roller Ø $d_1$ (mm)	Pin Ø $d_2$ (mm)	$L_1$ (mm)	Design A		Design B and C	
			P (mm)						$l_1$ (mm)	$L_2$ (mm)	$l_2$ (mm)	$l_3$ (mm)
<b>Pin design A, B, C</b>												
08 B-1	L 85 ML <sup>1)</sup>	1/2		12.7	7.75	8.51	4.45	25.5	10.0	40.5	25.0	13.0
10 B-1	M 106 ML <sup>1)</sup>	5/8		15.875	9.65	10.16	5.08	30.0	12.0	48.0	30.0	15.5
12 B-1	M 127 ML <sup>1)</sup>	3/4		19.05	11.75	12.07	5.72	36.0	15.0	51.0	30.0	15.5
16 B-1	M 1611 ML	1		25.4	17.02	15.88	8.28	53.8	20.0	68.5	35.0	18.0

<sup>1)</sup> For multiple chains on request. <sup>2)</sup> Nominal pitch. Other pin lengths and shapes on request.

### EXTENDED PINS

The types illustrated are also available as connecting links and outer links for final assembly and repair (C only as outer link).

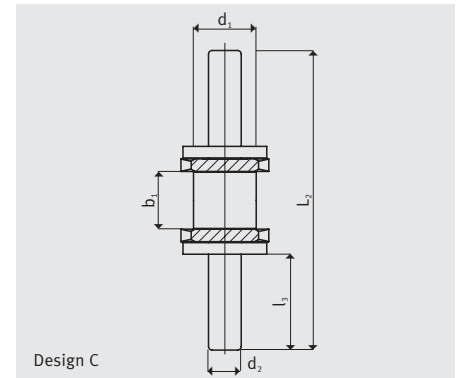
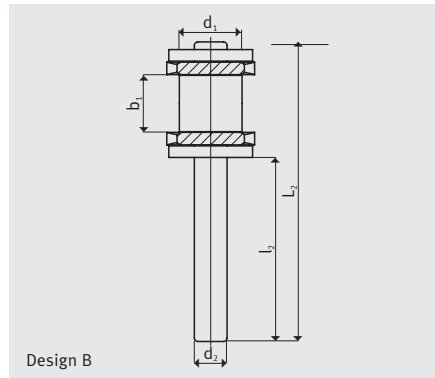
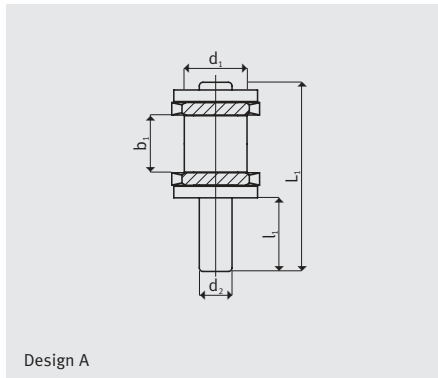

## iwis® MEGAlife I – Transfer Chains based on iwis roller chains complying with ISO 606

iwis reference	$B_1$	$b$	$h$	$H_1$	Article No. (5 m)
L 85 TF ML-1	20	7.5	3.1	15.4	50027317
M 106 TF ML-1	25	9.5	3.1	17.7	50036409
M 127 TF ML-1	30	11.3	2.9	20.0	50032663

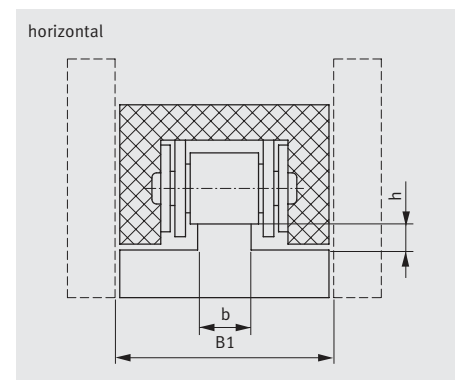
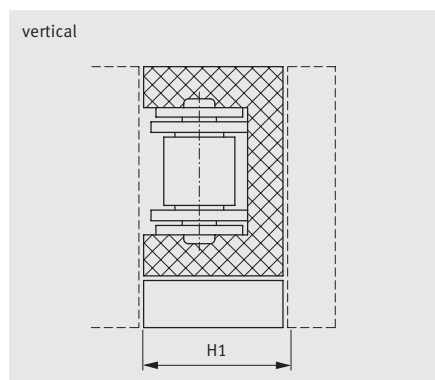



## **iwis**® MEGAlife II – Roller Chains according to ISO 606

ISO	iwis reference	Pitch p (")	Pitch p (mm)	Ave. tensile strength $F_a$ (N)	Min. tensile strength $F_u$ (N)	Bearing area $F$ (cm <sup>2</sup> )	Weight per m $q$ (kg/m)	$b_1$ (mm) min.	$b_2$ (mm) max.	$g$ (mm) max.	Inner link $a_1$ (mm) max. <sup>1)</sup>	Outer link $a$ (mm) max. <sup>1)</sup>	Roller $d_1$ (mm) max.	Pin $d_2$ (mm) max.	Transverse pitch $e$ (mm)	Article No.
<b>Simplex</b>																
06 B-1	G 67 ML-2*	3/8	9.525	11,000	8,900	0.28	0.41	5.72	8.53	8.20	12.90	14.10	6.35	3.31	–	50030791
08 B-1	L 85 ML-2	1/2	12.70	22,000	17,800	0.50	0.70	7.75	11.30	12.20	16.90	18.50	8.51	4.45	–	50030461
10 B-1	M 106 ML-2	5/8	15.875	25,000	22,200	0.67	0.95	9.65	13.28	14.40	19.50	20.90	10.16	5.08	–	50030462
12 B-1	M 127 ML-2	3/4	19.05	30,000	28,900	0.89	1.25	11.75	15.62	16.40	22.70	23.60	12.07	5.72	–	50030463
16 B-1	M 1611 ML-2	1	25.40	75,000	60,000	2.10	2.72	17.02	25.45	21.10	36.10	36.90	15.88	8.28	–	50030464
20 B-1	M 2012 ML-2	1 1/4	31.75	120,000	95,000	5.84	3.72	19.56	29.10	26.60	77.00	79.70	19.05	10.17	36.45	50033036
<b>Duplex</b>																
06 B-2	D 67 ML-2	3/8	9.525	19,000	16,900	0.56	0.78	5.72	8.53	8.20	23.40	24.60	6.35	3.31	10.24	50031074
08 B-2	D 85 ML-2	1/2	12.70	40,000	31,100	1.00	1.35	7.75	11.30	12.20	30.80	32.40	8.51	4.45	13.92	50030465
10 B-2	D 106 ML-2	5/8	15.875	49,000	44,500	1.34	1.85	9.65	13.28	14.40	36.00	37.50	10.16	5.08	16.59	50030466
12 B-2	D 127 ML-2	3/4	19.05	61,000	57,800	1.78	2.50	11.75	15.62	16.40	42.10	43.00	12.07	5.72	19.46	50030467
<b>Triplex – ML-2 Roller Chains on request</b>																
<b>Simplex – ANSI Roller Chains, complying with ISO 606, American Standard</b>																
08 A-1 ANSI 40	L 85 AML-2	1/2	12.70	17,500	13,900	0.44	0.60	7.94	11.15	12.00	16.60	17.50	7.95	3.96	–	50033770
12 A-1 ANSI 60	M 128 AML-2	3/4	19.05	41,000	31,300	1.06	1.47	12.70	17.75	18.00	25.30	26.70	11.91	5.96	–	50031073
16 A-1 ANSI 80	M 1610 AML-2	1	25.40	68,000	55,600	1.79	2.57	15.88	22.40	22.80	32.00	33.90	15.88	7.94	–	50032667

### ML-2 Conveyor Chains on request

<sup>1)</sup> Differing dimensions for cranked links. If cranked links are fitted, it should be noted that the breaking strength of the chain may be reduced by approximately 20%. \* straight side plates

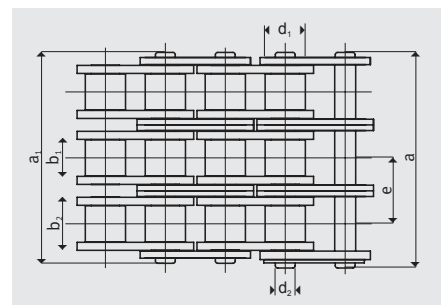
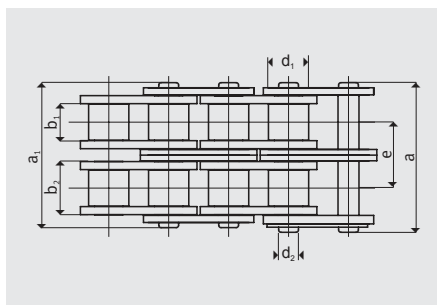
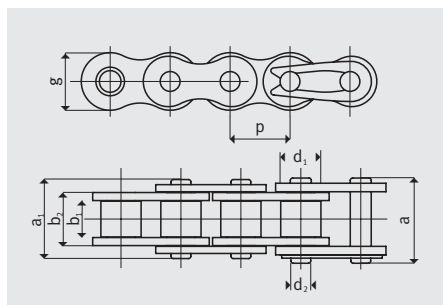

### INDIVIDUAL COMPONENTS AND CONNECTING LINKS



Standard designation B  
Inner link



Standard designation E  
Connecting link with spring clip



Standard designation C  
Double cranked link



Standard designation A  
Outer link

## **iwis**® MEGAlife Conveyor Chains

Examples of special chain designs

MEGAlife Conveyor Chain with straight attachment plates



MEGAlife Conveyor Chain with extendend pins

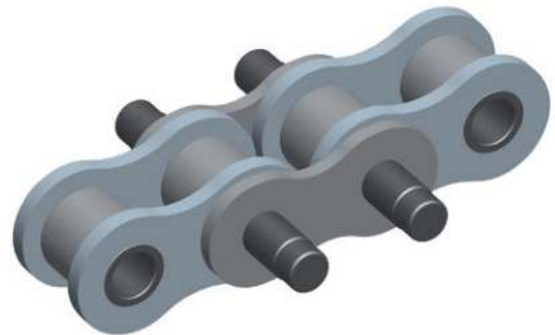

MEGAlife Conveyor Chain with bent attachment plates

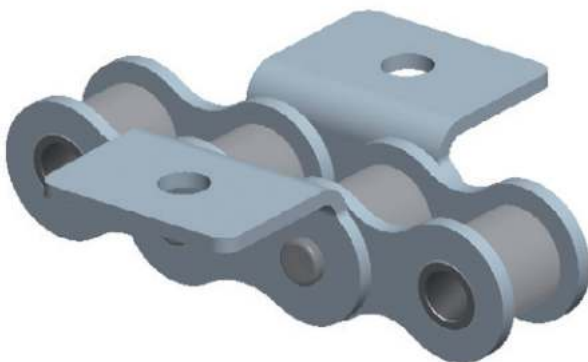

MEGAlife Conveyor Chain with special attachment plates

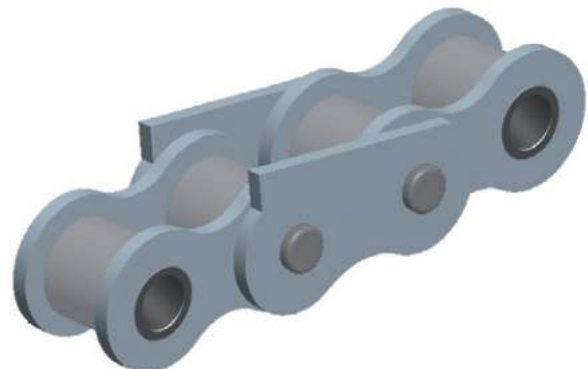

## **iwis**® MEGAlife Maintenance-Free Accumulation Chains

More efficiency and sustainability



### PROBLEM/INITIAL SITUATION

- Lubrication is not at all or only partly possible
- Clean and dry surroundings required
- Difficult/obstructed lubrication passage
- Contamination of installation and material to be conveyed due to chain lubrication

### OUR SOLUTION

iwis accumulation chains with nickel-plated plates and pins, low-friction sintered metal rollers and a special bearing design – a technical innovation. **The first genuinely maintenance accumulation chains with low-friction rollers on the market.**

#### Types:

- VR: with offset accumulation rollers
- OS: standard version without washers
- M: standard version with washers

### HIGHLIGHTS

- 1 **Special bearing design with sintered metal bushes**
- 2 Nickel-plated plates and pins, with eco-friendly, **lubricant-free surfaces** ensure reduced maintenance costs and less downtime for your application.

### HIGHLIGHTS

- Excellent wear resistance – also under extreme environmental conditions
- Easy to dismantle
- Environmentally-friendly due to lubrication free chain surface
- Chains suitable for clean rooms

### TECHNICAL FEATURES

- Dry chain surface and accumulation rollers
- Corrosion resistant
- Accumulation rollers optional as **plastic material or steel (stainless steel or nickel-plated)**
- Temperature range for use –40 °C up to +150 °C (for accumulation rollers made of steel)
- iwis MEGAlife accumulation chains are available in the new iwis or classic design in 1/2" and 3/4" pitch
- Accumulation rollers made of sintered metal reduce friction. This leads to reduction of driving power and strain on the chain.

### AREAS OF APPLICATION

- Electronic industry and circuit board manufacture
- Packaging and food industry
- Conveyor-equipment
- Wood, glass and ceramic industry
- Medical technology

... and of course in all areas where relubrication is not at all or only partly possible.

## **EFFICIENT**

### Comparison of frictional force

Chain with iwis low-friction rollers

Chain with classic idler rollers

## **LONG SERVICE LIFE**

### Service life comparison (accumulation chains without relubrication)

iwis MEGAlife maintenance-free accumulation chains

Std. competitor chains

## **ECONOMICAL**

### Comparison of friction coefficient

iwis MEGAlife chains

Standard competitor chains

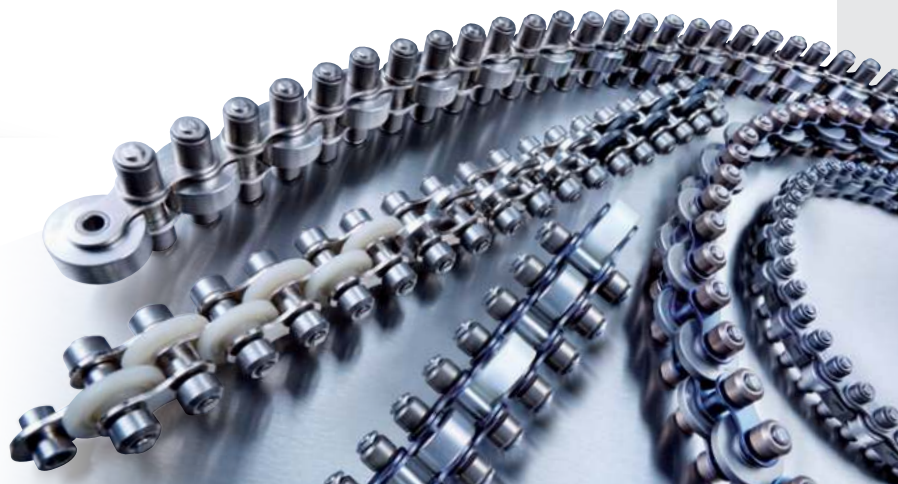

**30%** more efficient with iwis low-friction rollers

## MEGAlife Accumulation Chains

### Range of products

iwis reference	Pitch p (mm)	Chain width B (mm)	b (mm)	b <sub>4</sub> (mm)	e (mm)	Diameter accumulation rollers (mm)	Loading capacity per roller (kg)	Weight (kg/m)
<b>Design VR: Version with offset accumulation rollers*</b>								
L 88 SFK-ML	12.70	27	9.2	14.50	18.70	16.00	6	0.85
L 88 SFS-ML	12.70	27	9.2	14.50	18.70	16.00	8	1.40
M 120 SFK-ML	19.05	40	11.70	19.55	29.0	24.0 / 26.0 / 27.0 / 28.0	10	1.8
M 120 SFK-ML	19.05	45	11.70	19.55	31.5	24.0 / 26.0 / 27.0 / 28.0	10	1.8
M 120 SFS-ML	19.05	40	11.70	19.55	29.0	24.0 / 26.0 / 27.0 / 28.0	15	2.8
M 120 SFS-ML	19.05	45	11.70	19.55	31.5	24.0 / 26.0 / 27.0 / 28.0	15	2.8

Design VR: offset fitted rollers

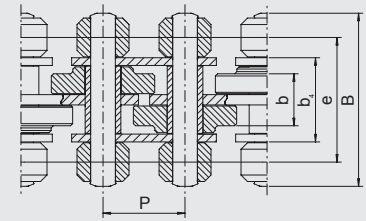

\* Also available with optional **V2A** accumulation rollers

**SFK** – with plastic accumulation rollers  
**SFS** – with hardened steel accumulation rollers

iwis reference	Pitch p (mm)	Chain width B (mm)	e (mm)	b <sub>1</sub> (mm)	b <sub>2</sub> (mm) max.	b <sub>3</sub> (mm) max.	Width b (mm)	Diameter accumulation rollers (mm)	Loading capacity per roller (kg)	Diameter Roller d <sub>1</sub> (mm)	Diameter Pin d <sub>2</sub> (mm)	Weight (kg/m)
<b>Design OS: Standard version without washers</b>												
L 85 SFK-ML	12.7	27	18.7	7.75	11.3	14.5	7.5	16.0	17.0	18.0	6	1.2
L 85 SFS-ML	12.7	27	18.7	7.75	11.3	14.5	7.5	16.0	17.0	–	8	1.8
M 127 SFK-ML	19.05	40	27.5	11.75	15.62	19.55	11.0	24.0	26.0	28.0	10	2.3
M 127 SFS-ML	19.05	40	27.5	11.75	15.62	19.55	11.0	24.0	26.0	28.0	15	3.1
<b>Design M: Standard version with side-mounted washers</b>												
M 127 SFK-ML	19.05	40	27.5	11.75	15.62	19.55	11.0	24.0	26.0	28.0	10	2.3
M 127 SFK-ML	19.05	43	29.0	11.75	15.62	19.55	11.0	24.0	26.0	28.0	10	2.3
M 127 SFK-ML	19.05	48	31.5	11.75	15.62	19.55	11.0	24.0	26.0	28.0	10	2.3
M 127 SFS-ML	19.05	40	27.5	11.75	15.62	19.55	11.0	24.0	26.0	28.0	15	3.1
M 127 SFS-ML	19.05	43	29.0	11.75	15.62	19.55	11.0	24.0	26.0	28.0	15	3.1
M 127 SFS-ML	19.05	48	31.5	11.75	15.62	19.55	11.0	24.0	26.0	28.0	15	3.1

Design OS without of washers

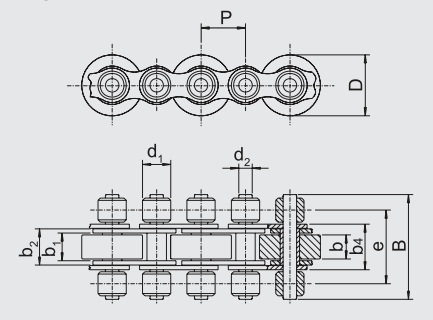

Design M normal pitch

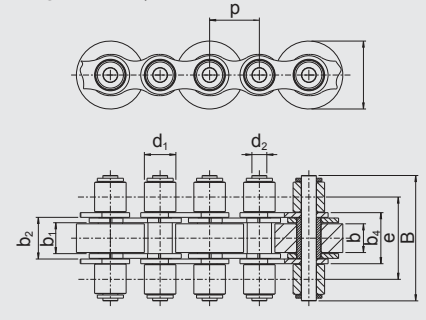

Connecting link

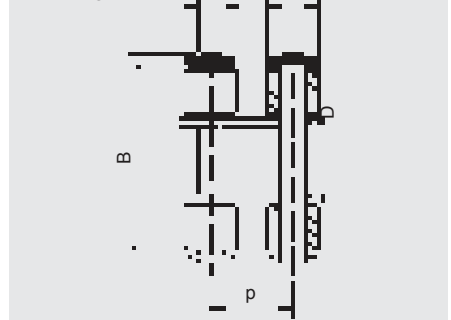

## **iwis**® MEGAlife Roller and Conveyor Chains

### Summary of benefits

#### MORE RELIABILITY



MEGAlife maintenance-free roller and conveyor chains offer a significantly longer service life than conventional low-maintenance/lube-free roller chains.

#### The benefits for you:

- Less downtime
- Longer replacement intervals for machine and system components
- Significant reduction of maintenance costs

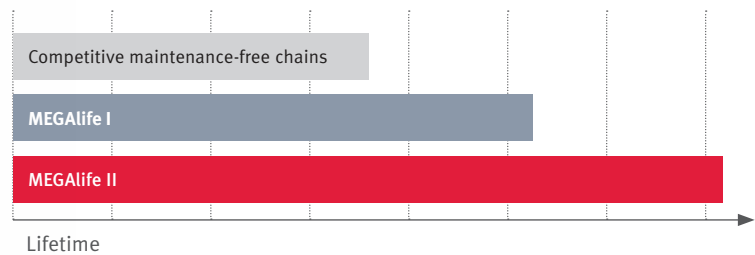

Trouble-free conversion of standard chains and conveyor chains to MEGAlife: **no additional adjustments or modifications required!**

#### MORE SUSTAINABILITY

### MEGAlife = lubricant-free

MEGAlife maintenance-free roller chains and conveyor chains require no lubrication, so they are clean, dry and **environment-friendly**.

#### The benefits for you:

- Built-in relubrication units in machines and systems are no longer required.
- Lower energy costs, lower investments
- Conservation of fossil resources

**iwis' own contribution for the environment!**



iwis has been awarded the **ISO 14001:2004** (Environmental Management System) certificate by the Technical Inspection Association TÜV SÜD for its achievements in the field of "Development, manufacture and distribution of drive chains and conveyor chains".





# CF Stainless Steel Chains

The new corrosion-free CF stainless steel chains from iwis are extremely reliable, fatigue- and corrosion-resistant. They are therefore ideal for applications in the food and beverage industry. Top iwis quality with an outstanding price-performance ratio.





**Corrosion-  
proof  
CF Series**

## JWIS® CF Stainless Steel Chains

Extreme anti-corrosion performance

Ideal for  
use in **food**  
applications



### BEST QUALITY

The new stainless steel CF chains, made of austenitic stainless steel, are **extremely reliable, fatigue- and corrosion-resistant**, so they are ideal for use in applications involving food and other contamination-sensitive products. Top iwis quality with an outstanding price-performance ratio.

### APPLICATIONS

- In aggressive environments
- In environments involving the application of water or steam and strict cleaning regulations
- In environments with extreme high temperatures

### HIGHLIGHTS

- All plates have a higher proportion of smooth cut edges, assuring **improved fatigue resistance, greater endurance** and reduced elongation, which in turn mean **longer service life and more stability**.
- All rollers are **seamless**, guaranteeing **smooth running** and extreme impact resistance at higher speeds.
- Seamless bushes reduce initial wear elongation and guarantee a significantly **higher positioning precision** than conventional stainless steel roller chains in operation. This is a major advantage in filling, conveying and packaging applications.
- **Restricted length tolerances** for even more accurate positioning
- Temperature range: -80 °C to +150 °C
- Various **special lubricants** available e.g. for high temperatures (up to max. 400 °C), low temperatures or food-grade lubricant with H1 approval
- Conveyor chains with **customer-specific attachments** can be configured and realised at short notice.
- Load-elongation diagrams can be created

**i** If your application calls for a corrosion-resistant chain with higher breaking strength and fatigue resistance than CF stainless steel chains, we recommend our corrosion-resistant **iwis CR chains**.

For more information, see the chapter **CR Chains**.

### SALT SPRAY TEST

In the standardised salt spray test, our CF stainless steel chains achieved higher corrosion resistance in comparison with standard corrosion-free chains available on the market.

JWIS stainless steel chains

Regular stainless steel chains





iwis reference	ISO	Pitch p (mm)	Inner width b1 min. (mm)	Roller d1 max. (mm)	Pin d2 max. (mm)	Pin length a1 max. (mm)	Pin length conn. link** a max. (mm)	Plate height g (mm)	Transverse pitch e (mm)	Min. tensile strength $F_u$ (N)	Article No.
<b>CF Stainless Steel Chains</b>											
G 67 CF*	06 B-1	9.525	5.72	6.35	3.28	13.5	16.8	8.2	-	6,400	40008144
D 67 CF*	06 B-2	9.525	5.72	6.35	3.28	23.8	27.1	8.2	10.24	11,000	40008147
L 85 CF	08 B-1	12.70	7.75	8.51	4.45	17.0	20.7	11.8	-	12,500	40008216
D 85 CF	08 B-2	12.70	7.75	8.51	4.45	31.0	34.9	11.8	13.92	22,000	40008149
M 106 CF	10 B-1	15.875	9.65	10.16	5.08	19.6	23.7	14.7	-	16,000	40008152
D 106 CF	10 B-2	15.875	9.65	10.16	5.08	36.2	40.3	14.7	16.59	29,000	40008153
M 127 CF	12 B-1	19.05	11.68	12.07	5.72	22.7	27.3	16.1	-	20,000	40008154
D 127 CF	12 B-2	19.05	11.68	12.07	5.72	42.2	46.8	16.1	19.46	35,000	40008156
M 1611 CF	16 B-1	25.40	17.02	15.88	8.28	36.1	41.5	21.0	-	40,000	40008157
D 1611 CF	16 B-2	25.40	17.02	15.88	8.28	67.0	73.4	21.0	31.88	85,000	40008158

\* With straight side plates \*\* a = Conn. link with spring clip CF = corrosion-free

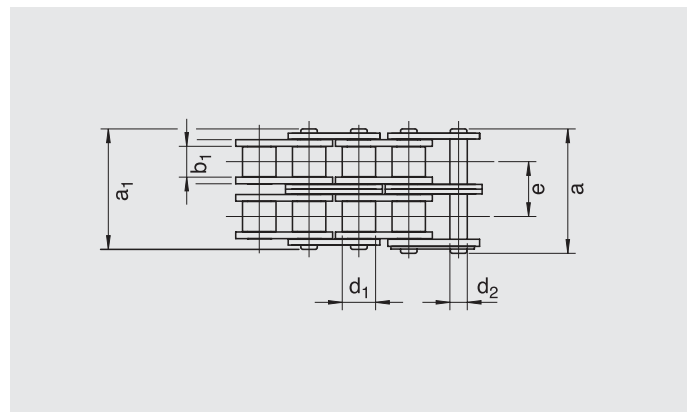
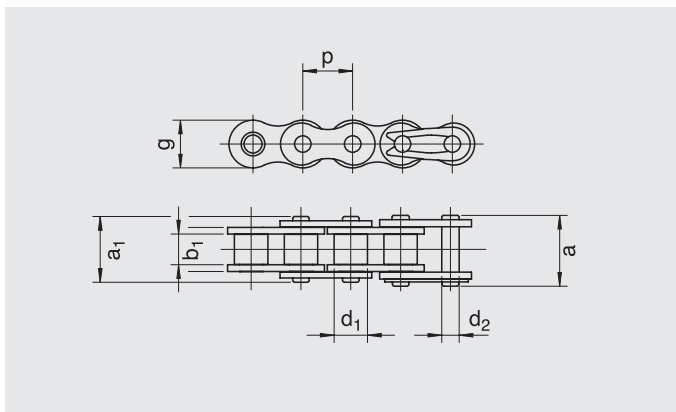

## iwis® CF Stainless Steel Chains with narrow bent attachments according to ISO 606

iwis reference	ISO	Inner width $b_1$ min. (mm)	Roller-Ø $d_1$ max. (mm)	Pin Ø $d_2$ max. (mm)	Pin length $a_1$ max. (mm)	Plate height $g$ (mm)	Transverse pitch $e$ (mm)	Min. tensile strength $F_0$ (N)	$c$ (mm)	$d$ (mm)	Attachment dimension **				
											$e_1$ (mm)	$f$ (mm)	$l$ (mm)	$s$ (mm)	
<b>CF Stainless Steel Chains with narrow bent attachments</b>															
G 67 CF *	06 B-1	5.72	6.35	3.28	13.5	8.2	-	6,400	6.5	3.5	9.5	13.5	8.0	1.1	
D 67 CF*	06 B-2	5.72	6.35	3.28	23.8	8.2	10.24	11,000	6.5	3.5	-	-	8.0	1.1	
L 85 CF	08 B-1	7.75	8.51	4.45	17.0	11.8	-	12,500	10.0	4.5	13.1	19.0	12.5	1.5	
D 85 CF	08 B-2	7.75	8.51	4.45	30.8	11.8	13.92	22,000	10.0	4.5	-	-	12.5	1.5	
M 106 CF	10 B-1	9.65	10.16	5.08	19.6	14.7	-	16,000	10.0	5.5	16.7	27.0	15.0	1.7	
D 106 CF	10 B-2	9.65	10.16	5.08	36.2	14.7	16.59	29,000	10.0	5.5	-	-	15.0	1.7	
M 127 CF	12 B-1	11.68	12.07	5.72	22.7	16.1	-	20,000	11.0	6.6	18.6	29.0	18.5	1.8	
D 127 CF	12 B-2	11.68	12.07	5.72	42.2	16.1	19.46	35,000	11.0	6.6	-	-	18.5	1.8	
M 1611 CF	16 B-1	17.02	15.88	8.28	36.1	21.0	-	40,000	18.0	9.0	28.9	41.8	25.0	3.0	
D 1611 CF	16 B-2	17.02	15.88	8.28	67.0	21.0	31.88	85,000	18.0	9.0	-	-	25.0	3.0	

\* With straight side plates \*\* Other dimensions also available on request CF = corrosion-free

**Design A**  
Bent attachment on one side  
2020.1

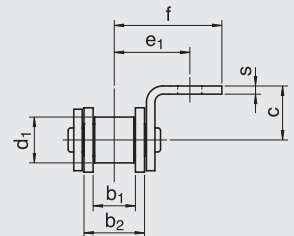
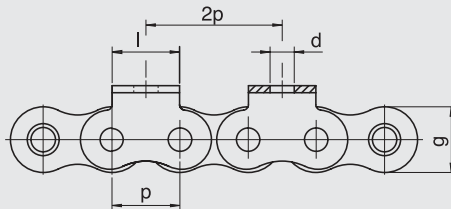

**Design B**  
Bent attachment on both sides  
2020.1

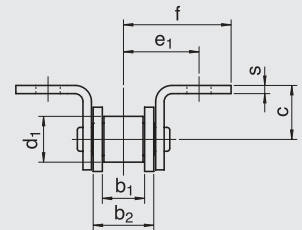
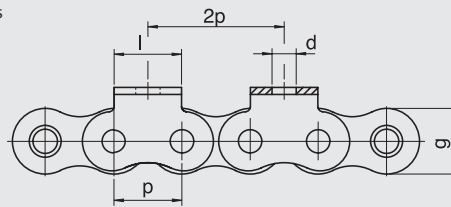

## **iwis**® CF Stainless Steel Chains with wide bent attachments according to ISO 606

iwis reference	ISO	Inner width b1 min. (mm)	Roller Ø d1 max. (mm)	Pin Ø d2 max. (mm)	Pin length a1 max. (mm)	Plate height g (mm)	Transverse pitch e (mm)	Min. tensile strength $F_u$ (N)	c (mm)	d (mm)	Attachment dimension **				
											$e_1$ (mm)	f (mm)	i (mm)	l (mm)	s (mm)
<b>CF Stainless Steel Chains with wide bent attachments</b>															
G 67 CF *	06 B-1	5.72	6.35	3.28	13.5	8.2	-	6,400	5.7	3.2	9.8	13.2	9.525	18.2	1.1
D 67 CF *	06 B-2	5.72	6.35	3.28	23.8	8.2	10.24	11,000	5.7	3.2	9.8	13.2	9.525	-	1.1
L 85 CF	08 B-1	7.75	8.51	4.45	17.0	11.8	-	12,500	10.0	4.5	13.1	19.0	12.7	23.2	1.5
D 85 CF	08 B-2	7.75	8.51	4.45	30.8	11.8	13.92	22,000	10.0	4.5	13.1	19.0	12.7	-	1.5
M 106 CF	10 B-1	9.65	10.16	5.08	19.6	14.7	-	16,000	10.0	5.5	16.7	27.0	15.9	28.5	1.7
D 106 CF	10 B-2	9.65	10.16	5.08	36.2	14.7	16.59	29,000	10.0	5.5	16.7	27.0	15.9	-	1.7
M 127 CF	12 B-1	11.68	12.07	5.72	22.7	16.1	-	20,000	11.0	6.6	18.6	29.0	19.1	34.8	1.8
D 127 CF	12 B-2	11.68	12.07	5.72	42.2	16.1	19.46	35,000	11.0	6.6	18.6	29.0	19.1	-	1.8
M 1611 CF	16 B-1	17.02	15.88	8.28	36.1	21.0	-	40,000	18.0	9.0	28.9	42.0	25.4	46.5	3.0
D 1611 CF	16 B-2	17.02	15.88	8.28	67.0	21.0	31.88	85,000	18.0	9.0	28.9	42.0	25.4	-	3.0

\* With straight side plates \*\* Other dimensions also available on request CF = corrosion-free

**Design A2**  
Bent attachment on one side  
2030.2

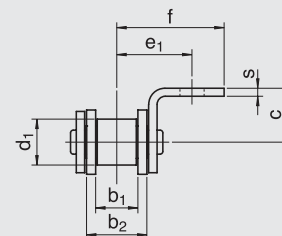
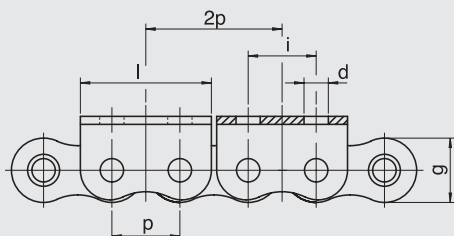

**Design B2**  
Bent attachment on both sides  
2030.2

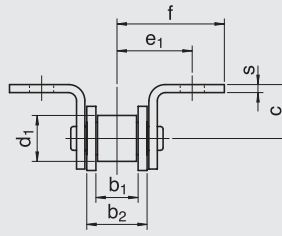
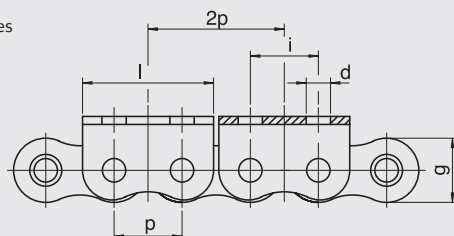

## iwis® CF Stainless Steel Chains with extended pins according to ISO 606

iwis reference	ISO	Inner width b1 min. (mm)	Roller-Ø d1 max. (mm)	Pin Ø d2 max. (mm)	Pin length a1 max. (mm)	Conveyor rivet length L1 max. (mm)	Conveyor rivet length L2 max. (mm)	Pin lengths max.			Min. tensile strength $F_u$ (N)
								$l_1$ (mm)	$l_2$ (mm)	$l_3$ (mm)	
<b>CF Stainless Steel Chains with extended pins</b>											
G 67 CF *	06 B-1	5.72	6.35	3.28	13.5	23.2	33.5	10.9	21.2	11.2	6,400
L 85 CF	08 B-1	7.75	8.51	4.45	17.0	30.9	44.9	15.2	29.2	15.2	12,500
M 106 CF	10 B-1	9.65	10.16	5.08	19.6	36.2	52.8	17.9	34.5	17.9	16,000
M 127 CF	12 B-1	11.68	12.07	5.72	22.7	42.8	61.3	20.7	40.2	20.9	20,000
M 1611 CF	16 B-1	17.02	15.88	8.28	36.1	67.0	98.9	33.1	65.0	33.6	40,000

\* With straight side plates CF = corrosion-free For missing dimensions see Standard CF Chains.

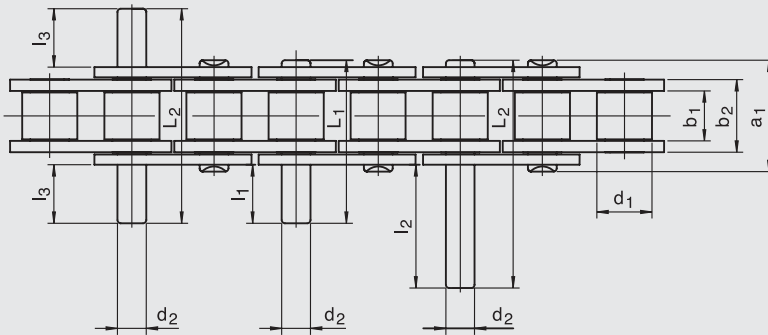
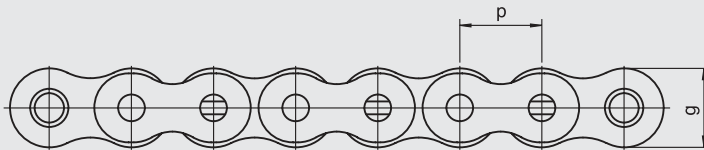

## Notes

A large, empty grid of graph paper, consisting of a 20x30 grid of small squares, intended for taking notes.

**NEW**  
by iwis

## **JWTS<sup>®</sup>** b.dry maintenance-free Stainless Steel Chains

**More than just stainless steel!** The **lubricant-free bushes** of b.dry chains are made of a specially designed high-performance polymer that is extreme resistant to aggressive media. The combination of optimised bearing design and rustproof CF stainless steel means that b.dry chains are **significantly more durable and wear-resistant** than comparable products. And absolutely dry, too.



## **iwis® b.dry maintenance-free Stainless Steel Chains**

Extremely wear-resistant, corrosion-free and absolutely dry!

### BEST QUALITY

b.dry chains are made from **corrosion-free, maintenance-free CF stainless steel with an optimized articulated link** that represents a masterpiece of high precision.

The secret of the b.dry range is to consign the old notions of „steel on steel“ to the past! The fact that no lubricants are needed is thanks to our b.dry bushes, which are made from a special, high-performance polymer.

The capabilities of this material are absolutely unparalleled. b.dry products run **completely dry**, but are still more **resistant to wear and corrosion, stronger** and have a **longer service life** than comparable chains.

In a dry state twice as good, with initial lubricant even four times as good. **A worthwhile investment in every respect.**

### HIGHLIGHTS

- Properties of individual parts that are perfectly harmonized with each other reduce chain wear and dramatically increase service life. b.dry chains are extremely reliable, withstand high dynamic loads and are corrosion-resistant.
- b.dry chains are completely dry-running. No lubrication is necessary, thanks to a high-performance plastic friction bearing in the articulated link.
- Extremely high resistance to aggressive media. Information on chemical resistance of the b.dry chains and bush available on request.
- Length tolerances compliant with ISO 606.
- Temperature range: -100 °C to +200 °C.
- No relubrication required.
- Also available as roller chains with attachments or extended pins and as custom-developed chains. ANSI chains also on request.

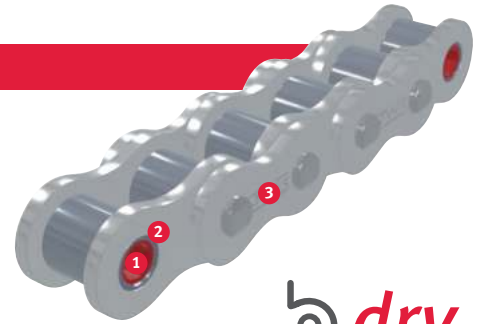

**b dry**

- High-performance polymer bushes **1** are FDA-compliant, friction-efficient and heavy-duty. Completely safe in contact with foodstuffs or other hygiene-sensitive goods.
- Stainless-steel bushes: **2** thin-walled, seamless and ball-drifted. This means that b.dry chains achieve greater strength and significantly higher wear resistance.
- CF basic chain made of austenitic stainless steel. **3**

### WEAR LIFE

Wear life Chain **dry**

Competitor

iwis M 127CF **b.dry**

**2x**

as good as the competition

Wear life Chain with **initial lubrication** (upon request)

Competitor

iwis D 127CF **b.dry**

**4x**

as good as the competition

### APPLICATIONS

- In aggressive environments
- In environments in which water or steam are applied and with strict cleaning regulations for e.g.:
- Pharmaceutical industry
- Automobile industry paint lines
- Food processing industry
- Clean room applications

In a dry state **PWIS-free**

### FLYER

See our product flyer for more information.



**b dry**

More than just  
stainless steel!





iwis reference	DIN ISO	Pitch p (mm)	Inner width b1 min. (mm)	Roller Ø d1 max. (mm)	Pin Ø d2 max. (mm)	Pin length a1 max. (mm)	Length grooved pin** a max. (mm)	Plate height g (mm)	Traverse pitch e (mm)	Min. tensile strength (N)	Article no.
<b>b.dry Stainless Steel Chains</b>											
L 85 CF <b>b.dry</b>	08 B-1	12.70	7.75	8.51	4.45	17.0	20.7	11.8	-	12,500	40009443
D 85 CF <b>b.dry</b>	08 B-2	12.70	7.75	8.51	4.45	31.0	34.9	11.8	13.92	22,000	40009454
M 106 CF <b>b.dry</b>	10 B-1	15.875	9.65	10.16	5.08	19.6	23.7	14.7	-	16,000	40009451
D 106 CF <b>b.dry</b>	10 B-2	15.875	9.65	10.16	5.08	36.2	40.3	14.7	16.59	29,000	40009455
M 127 CF <b>b.dry</b>	12 B-1	19.05	11.68	12.07	5.72	22.7	27.3	16.1	-	20,000	40009452
D 127 CF <b>b.dry</b>	12 B-2	19.05	11.68	12.07	5.72	42.2	46.8	16.1	19.46	35,000	40009456
M 1611 CF <b>b.dry</b>	16 B-1	25.40	17.02	15.88	8.28	36.1	41.5	21.0	-	40,000	40009453

\*\* a = Spring connecting link CF = corrosion-free Roller chains with standard attachments and custom designs can be implemented. ANSI chains on request.

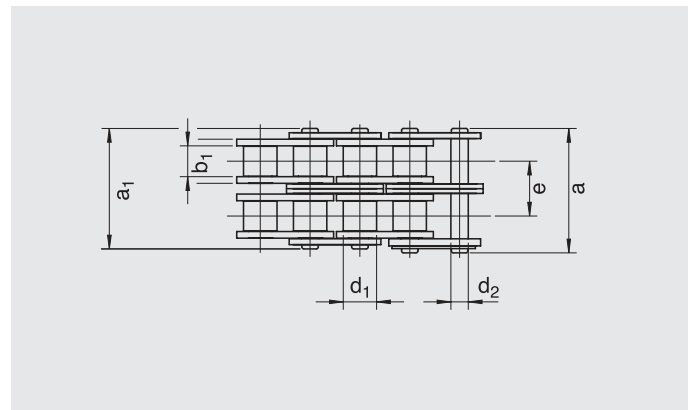
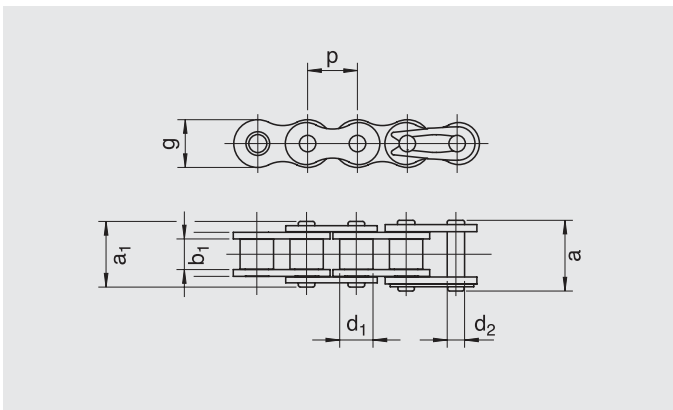

## Chain elongation performance of a b.dry roller chain with and without initial lubrication

The performance of the chain can be increased fourfold by using our lubricant, which has been approved for use with foodstuffs.

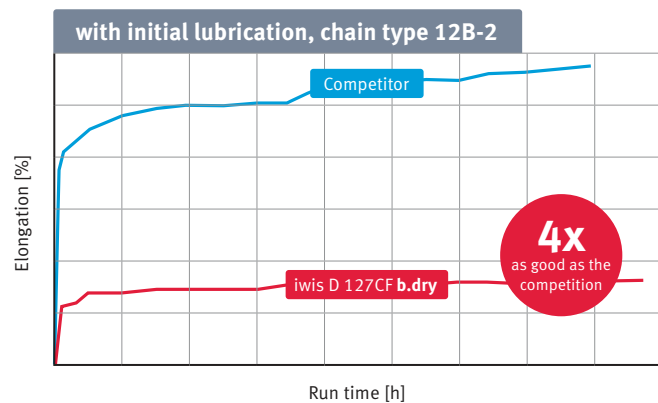
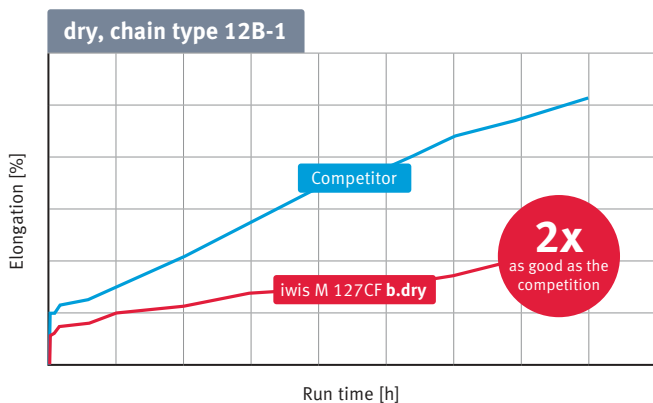

Figures not to scale.

# JWIS<sup>®</sup> CR Chains

Jwis corrosion-resistant chains consist of hardened, highly alloyed steels showing a good wear resistance and considerably higher fatigue and breaking strengths than for stainless chains. CR chains can be used in those applications where chains despite of extreme conditions need to remain flexible and stainless due to hygienic and visual reasons. A lubrication of CR chains is recommended.





## iwis® CR Chains

Corrosion-resistant roller chains and conveyor chains according to ISO 606

### PROBLEM/INITIAL SITUATION

Chains in corrosive media have to possess high fatigue and wear resistance. Chains made of standard steels corrode quickly whilst stainless steels made of V2-A steel do not withstand these stresses. Nickel-plated or galvanised chains only offer limited corrosion-proofing because the coating is destroyed by abrasion.

### OUR SOLUTION

CR: iwis high performance chains made of hardened high-alloyed steels with good corrosion resistance and significantly higher strength than stainless steel chains.

### HIGHLIGHTS

- High wear resistance if relubrication is done at regular intervals
- Good and long-lasting corrosion resistance – in comparison with surface-coated chains
- Significantly higher fatigue resistance and breaking strength figures than stainless steel chains  
→ smaller dimensions possible

### TECHNICAL FEATURES

	iwis CR	iwis Standard	Stainless Chain
All components	hardened	hardened	not hardened
Pre-stretched	yes	yes	not regularly
Fatigue strength	80%	100%	50%
Wear resistance	95%	100%	30%

### AREAS OF APPLICATION

- Food product processing
  - Drinks manufacture
  - Packaging machines
  - Cheese and dairy technology
  - Areas where dominate moist or aggressive conditions
  - Cleaning systems
  - (Chemical) equipment construction
- ...and everywhere where chains have to remain articulated despite difficult conditions as a consequence of corrosion and may not rust on hygienic or visual grounds.

### CORROSION RESISTANCE

All CR chains are provided with a reliable high quality initial lubrication.

For permanent corrosion resistance, a sufficient regular relubrication is necessary.

ISO no.	iwis reference	Sales designation Pitch x inner width	$a_1$ (mm)	Outside width $a$ (mm)	$d_1$ (mm)	Diameter $d_2$ (mm)	Plate height (mm)	Tensile strength $F_B$ (N)	Bearing area $f$ (cm <sup>2</sup> )	Weight $q$ (kg/m)
08 B-1	L 85 CR	1/2 x 5/16"	16.9	18.5	8.51	4.45	12.2	15,000	0.50	0.70
10 B-1	M 106 CR	5/8 x 3/8"	19.5	20.9	10.16	5.08	14.4	18,000	0.67	0.95
12 B-1	M 127 CR	3/4 x 7/16"	22.7	23.6	12.07	5.72	16.4	22,000	0.89	1.25

### RUST- AND ACID-RESISTANCE

Dependent on

- duration
- concentration
- temperature
- variations of the mixture of the individual media. We recommend field trials to check fitness for the operational purpose.

### CHAIN SPROCKETS

Depending on the circumstances, chain sprockets can be used which are made of

- stainless material
- suitable plastics
- or steel, possibly with an electro-plated coating.

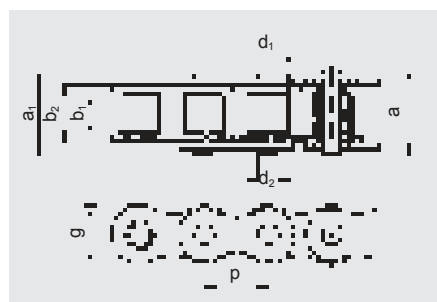

## Influencing Parameters

Technical outline: Which are the major factors causing corrosion?

### THE MAJOR PARAMETERS CAUSING CORROSION

There are four main factors causing corrosion:

- the medium in which the chain moves
- the material the chain is made from
- the construction of the component
- the run time and way of application (continuous, periodically, seasonal)

### CORROSION FACTORS

All CR Chains are provided with a reliable high quality initial lubrication.  
For permanent corrosion resistance, a sufficient regular relubrication is necessary.

CONSTRUCTION	MATERIAL	MEDIUM	TIME INFLUENCE
<ul style="list-style-type: none"> <li>• Surface condition</li> <li>• Other materials in environment</li> <li>• Assembly (welding and riveting)</li> <li>• Mechanical stress</li> <li>• Design</li> <li>• Protective measures</li> <li>• Contact to medium (partial or total dipping)</li> </ul>	<ul style="list-style-type: none"> <li>• Steel product</li> <li>• Alloying additive</li> <li>• Metallurgic condition (heat treatment and mechanical treatment)</li> <li>• Pollution</li> <li>• Composition</li> </ul>	<ul style="list-style-type: none"> <li>• Motion of medium</li> <li>• Chemical condition</li> <li>• Viscosity</li> <li>• Pollution</li> <li>• PH-value (acidity)</li> <li>• Temperature</li> <li>• Pressure</li> <li>• Concentration</li> <li>• Solid deposit</li> </ul>	<ul style="list-style-type: none"> <li>• Maintenance frequency</li> <li>• Relubrication intervall</li> <li>• Relubrication medium</li> <li>• Aging of structure</li> <li>• Tension development</li> <li>• Change of inert layer</li> <li>• Temperature changes</li> </ul>

All corrosion factors influence the corrosion resistance to the same extent.  
**Please refer to our Technical Service Team for professional support.**



# **JWIS**® **b.triton corrosion-resistant Chains**

Our new **b.triton** chains are the optimal solution when stainless steel reaches its strength limit and common coatings can no longer resist corrosion when exposed to harsh outdoor environments. **b.triton** chains use a high performance zinc-flake technology combined with a unique surface treatment to provide a protective finish that is **more corrosion resistant than any other coated chain** on the market.



 ***triton***

## JWIS® b.triton Chain

Pushing the limits of corrosion resistance!

### MAXIMUM CORROSION PROTECTION

Besides providing outstanding corrosion protection, the unique combination of carefully selected coatings also gives the chain **ideal wear running characteristics**. In the standardized salt spray test, JWIS b.triton chains demonstrate a much **higher corrosion resistance** than comparable competitors' products available on the market.

The unique characteristics of the special zinc flake coating ensure outstanding adhesion to the base material. An additional salt spray test with chains already in operational use confirmed that the chain is reliably protected against corrosion, even under harsh conditions:

### B.TRITON HIGHLIGHTS

- Best corrosion protection: up to 1,000 hours of salt spray testing in accordance with ISO 9227
- Special coating of chain links for added wear resistance
- Carefully selected high-quality carbon steel offers outstanding strength
- Suitable for temperatures from -10 °C to +130 °C thanks to a new initial lubricant iwiDUR-G
- Extended operating range up to 150 °C with high-temperature lubrication possible
- Extruded bushes and rollers for even better corrosion resistance, reduced run-in elongation and quieter running
- Environmentally friendly: materials comply with RoHS and are free from CrVI

### APPLICATION FIELDS

Environments with high **water/water vapour loads**, or stringent cleaning requirements in combination with extremely high standards of chain strength.

#### Application examples:

- In rough outdoor conditions
- Automated multi-storey car parks
- In slaughterhouses
- In the food industry
- In port applications
- In building engineering services

### MAXIMUM CORROSION PROTECTION COMBINED WITH OUTSTANDING WEAR RESISTANCE

A perfectly balanced combination of high-tech coatings ensures not only maximum corrosion protection, but also outstanding wear resistance properties!

**Special coatings** on bushes and pins reduce wear in **JWIS b.triton** chain joints. The new lubricant **"iwiDUR-G"**, developed especially for the applications in

which b.triton chains are used, provides additional protection against wear and corrosion.



All chains delivered with **iwiDUR-G**, a high-performance grease with outstanding wear resistance properties and additional corrosion protection, as standard. Alternative lubricants, for example with food-grade approval or suitable for high-temperature applications, are available on request.

For further information,  
see our product flyer or visit  
[www.iwis.com](http://www.iwis.com)





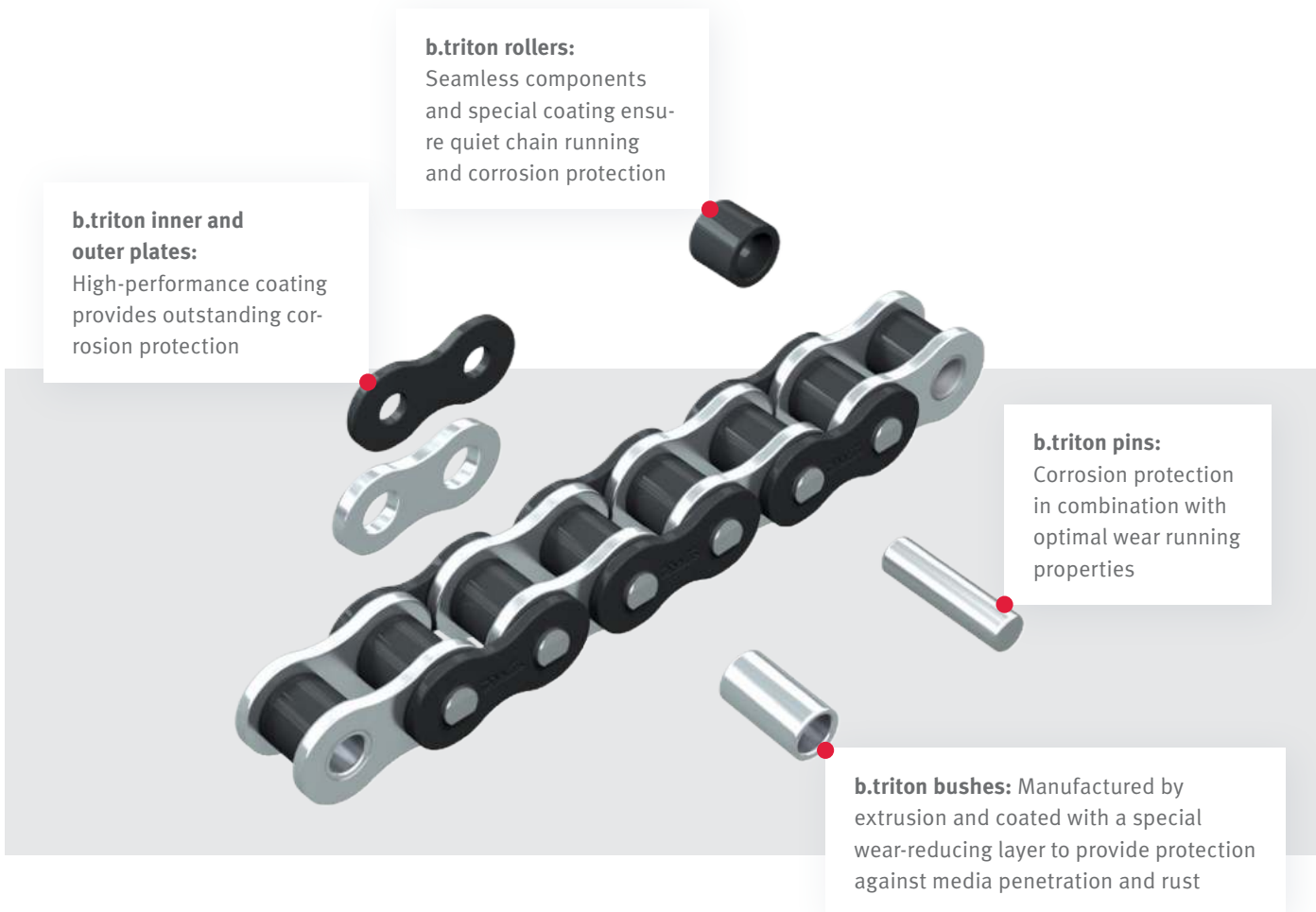

## **b.triton** Product range

ISO	iwis reference	Pitch p (")	Pitch p (mm)	F <sub>s</sub> ave. (N)	Tensile strength		Inner Link			Outer Link				
					F <sub>0</sub> /iwis min. (N)	Weight per meter q (kg/m)	Inner width b <sub>1</sub> (mm) min.	Inner link width b <sub>2</sub> (mm) max.	Plate height g (mm) max.	Pin length a <sub>1</sub> (mm) max.	Pin length conn. Link a (mm) max.	Roller diameter d <sub>1</sub> (mm) max.	Pin diameter d <sub>2</sub> (mm) max.	Transverse pitch e (mm)
<b>Simplex</b>														
08 B-1	L 85 b.triton	1/2"	12.70	19,800	17,800	0.67	7.75	11.30	11.81	17.0	19.2	8.51	4.45	-
10 B-1	M 106 b.triton	5/8"	15.875	27,000	22,200	0.92	9.65	13.28	14.73	19.6	22.5	10.16	5.08	-
12 B-1	M 127 b.triton	3/4"	19.05	32,700	28,900	1.19	11.68	15.62	16.13	22.7	25.3	12.07	5.72	-
16 B-1	M 1611 b.triton	1"	25.40	75,000	60,000	2.72	17.02	25.45	21.08	36.1	41.2	15.88	8.28	-
40-1	L 85A b.triton	1/2"	12.70	*	13,900	0.60	7.85	11.17	12.07	17.8	19.2	7.92	3.98	-
50-1	M 106A b.triton	5/8"	15.875	*	21,800	1.02	9.40	13.84	15.09	21.8	23.4	10.16	5.09	-
60-1	M 128A b.triton	3/4"	19.05	*	31,300	1.46	12.57	17.75	18.10	26.9	28.6	11.91	5.96	-
80-1	M 1610A b.triton	1"	25.40	*	55,600	2.72	15.75	22.60	24.13	33.5	36.6	15.88	7.94	-
100-1	M 2012A b.triton	1 1/4"	31.75	*	87,000	4.13	18.90	27.45	30.17	41.1	45.0	19.05	9.54	-
<b>Duplex</b>														
08 B-2	D 85 b.triton	1/2"	12.70	40,000	31,100	1.31	7.75	11.30	11.81	31.0	33.8	8.51	4.45	13.92
10 B-2	D 106 b.triton	5/8"	15.875	56,000	44,500	1.82	9.65	13.28	14.73	36.2	39.4	10.16	5.08	16.59
12 B-2	D 127 b.triton	3/4"	19.05	68,000	57,800	2.35	11.68	15.62	16.13	42.2	44.6	12.07	5.72	19.46
16 B-2	D 1611 b.triton	1"	25.40	150,000	106,000	5.39	17.02	25.45	21.08	68.0	73.4	15.88	8.28	31.88
40-2	D 85A b.triton	1/2"	12.70	*	27,800	1.20	7.85	11.17	12.07	32.3	33.8	7.92	3.98	14.38
50-2	D 106A b.triton	5/8"	15.875	*	43,600	2.03	9.40	13.84	15.09	39.9	42.2	10.16	5.09	18.11
60-2	D 128A b.triton	3/4"	19.05	*	62,600	2.99	12.57	17.75	18.10	49.8	51.6	11.91	5.96	22.78
80-2	D 1610A b.triton	1"	25.40	*	111,200	5.41	15.75	22.60	24.13	62.7	66.3	15.88	7.94	29.29

\* Average tensile strength values available soon

# **JWTS**® Accumulation Chains

The new-generation iwis accumulation chains L 88SF and M 120SF combine an optimized load distribution with a more gentle and even transport of the conveyed goods. The synthetic chain guides are capable of carrying up to twice the weight because the offset roller arrangement on which the chains run reduces the load on the guides by 50 %.

iwis accumulation chains allow easy positioning of the transported material at any point along the transport path and remove the need to start and stop the chain, thereby unsettling the conveyed material. The normal chain speed is 0.1 to 0.5 m/s. By fitting a simple acceleration rail, the conveying speed can be doubled (at locations in which material is not accumulated) without changing the chain speed. This is often used to separate goods.

Thanks to a special wax lubricant, the chains are low-maintenance. Applied only to the actual links during the assembly of the chains, the conveying rollers – and therefore the conveyed material – remain clean and have no contact with the lubricant. A special-purpose initial lubrication can be used for special-purpose applications. Accumulation rollers are available in the following materials: hardened steel, stainless steel, nickel-plated or plastic (also antistatic).





## iwis® Accumulation Chains

for more efficient conveyor systems. Cost-effective and long-lasting.

### PRODUCT RANGE

PREMIUM  
quality

### MEGAlife Accumulation Chains

Maintenance-free iwis accumulation chains with nickel-plated plates and pins, low-friction sintered metal rollers and special bearing design are used mainly in the electronics industry, food industry, timber, glass and ceramics processing, medical technology, automotive industry conveyors and all other applications where relubrication is problematic or impossible.

Outstanding wear resistance –  
even under extreme conditions!



- 1 Special bearing design with sintered metal bushes
- 2 Nickel-plated plates and pins, with eco-friendly, lubricant-free surfaces ensure reduced maintenance costs and less downtime for your application.

TOP  
product

### Accumulation Chains with offset accumulation rollers from iwis

This exclusive iwis accumulation chain generation has offset accumulation rollers on each pin, rather than a single wide roller on every second pin. As a result, each pin has a load-bearing function and transfers this load to twice as many rollers. This, has an extremely positive effect on chain guides.

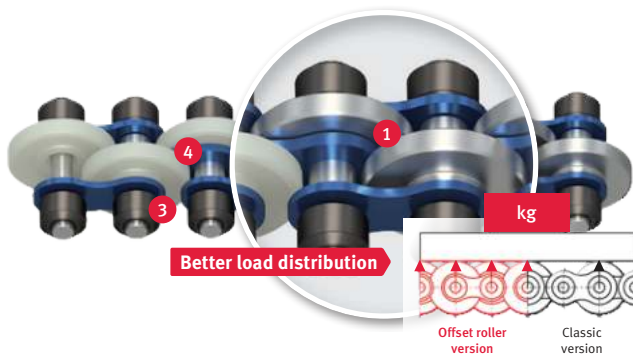

- 1 Offset arrangement of the accumulation rollers ensures optimised load distribution, better support and smoother running of the conveyed material.
- 2 Offset arrangement of the accumulation rollers reduces local load on the chain guide by **50%**. For example, plastic guides can be used for up to double the load.
- 3 Low-friction sintered metal rollers
- 4 Special bearing design

### Accumulation Chains from iwis

iwis accumulation chains have support rollers on both sides that serve two purposes: firstly, they engage with the sprocket teeth to transmit power, and secondly, they support the chain in the profile. One special feature are the slightly protruding bushes in the inner link 1 which prevent contact corrosion between inner link and outer plate.

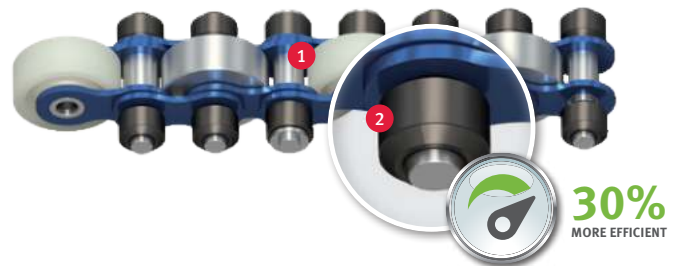

All 1/2" and 3/4" iwis accumulation chains are fitted with low-friction sintered metal rollers 2 that provide **consistent and extreme light running** and are not slowed down by lubricant. The length of our application conveyor can therefore be built about **30% longer** without any need for modification of the drive motors; alternatively, if the system length remains unchanged, smaller drive units may be fitted. Less strain on the chain and drive means **a longer service life for the entire conveyor system.**

NEW  
from iwis

## **b.smart** Accumulation Chain

**Know-how meets efficiency** – the new iwis **b.smart** accumulation chain. Configured for most conveyor applications – designed for optimum transportation of conveyed material.

Put robust, durable **b.smart** accumulation chains to work for you – proven **DVWS**® quality at an attractive price!



### Optimum relubrication

The service life of a chain depends on correct and adequate relubrication. After a certain time, which may vary according to operating conditions, the lubricant applied originally is eventually used up due to the oscillating motion of the chain bearing. Inadequate lubrication causes boundary friction, which in turn leads to fretting corrosion and increased chain wear. Selection of the correct lubricant and lubrication method are therefore a decisive factor in assuring that the relubrication process is effective.

ABSOLUTELY  
safe

## Protection for fingers + parts

Accumulation chains with finger and small parts protection feature optimum cover of the space between one accumulation roller and the next, preventing the ingress of small parts that could jam the rollers and/or chain link. In addition, the cover prevents the deliberate or accidental insertion of fingers while the conveyor is operating – an active contribution to accident prevention in line with increasingly strict industrial safety requirements.

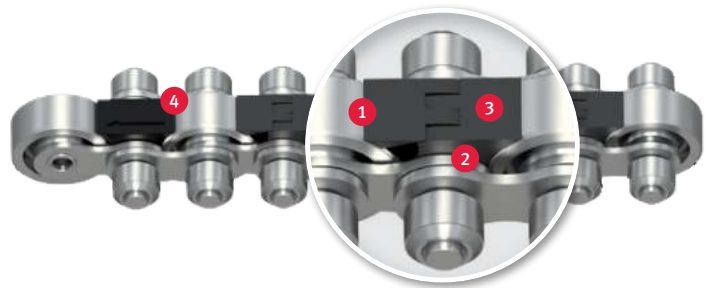

### Safety for operators and machines

- 1 100% cover of the space between accumulation rollers in accordance with required bend radii of the selected chain type
- 2 Firm mounting of plastic clip on inner link
- 3 No abrasive strain on conveyed goods, workpiece carriers or accumulation rollers
- 4 Two different finger protection versions – with and without joint



EXTREMELY  
flexible

## Side Bow Accumulation Chains

iwis side bow accumulation chain with offset rollers 1: The modular solution for direction changes in conveyor systems with extremely tight bend radii (> 350 mm). Optimum load distribution as transported material lies flat on links 2 even in bends, thus reducing chain wear.



### Standard solution

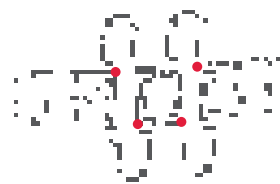

• Points of contact

### Our solution



— Lines of contact

## iwis® MEGAlife Accumulation Chains

Maintenance-free iwis accumulation chains



### PROBLEM/INITIAL SITUATION

- Lubrication is not at all or only partly possible
- Clean and dry surroundings required
- Difficult/obstructed lubrication passage
- Contamination of installation and material to be conveyed due to chain lubrication

### OUR SOLUTION

Accumulation chains from iwis with special redesigned joint and accumulation rollers made of sintered metal – a technical innovation – **the first genuine maintenance-free accumulation chains with light running rollers.**

#### Types:

- VR: with offset accumulation rollers
- OS: standard version without washers
- M: standard version with washers

### HIGHLIGHTS

- 1 **Special bearing design with sintered metal bushes**
- 2 Nickel-plated plates and pins, with eco-friendly, **lubricant-free surfaces** ensure reduced maintenance costs and less downtime for your application.

### ADDITIONAL HIGHLIGHTS

- Excellent wear resistance – also under extreme environmental conditions
- Easy to dismantle
- Environmentally-friendly due to lubrication free chain surface
- Chains suitable for clean rooms

### TECHNICAL FEATURES

- Dry chain surface and accumulation rollers
- Corrosion resistant
- Accumulation roller materials available: plastic or steel (V2A or nickel plated)
- Temperature range for use –40 °C up to +150 °C (for accumulation rollers made of steel)
- Accumulation chains can be supplied as Type VR or standard version in the sizes 1/2" and 3/4"
- Accumulation rollers made of sintered metal reduce friction. This leads to reduction of driving power and strain on the chain
- Natural-coloured, antistatic plastic accumulation rollers will not dirty the conveyed goods

### AREAS OF APPLICATION

- Electronic industry and circuit board manufacture
- Packaging and food industry
- Conveyor equipment
- Wood, glass and ceramic industry
- Medical technology

... and of course in all areas where relubrication is not at all or only partly possible.

### EFFICIENT

Comparison of frictional force

Chain with iwis low-friction rollers

Chain with classic idler rollers

### LONG SERVICE LIFE

Service life comparison (accumulation chains without relubrication)

iwis MEGAlife maintenance-free accumulation chains

Std. competitor chains

### ECONOMICAL

Comparison of friction coefficient

iwis MEGAlife chains

Standard competitor chains



30% more efficient with iwis low-friction rollers



iwis reference	Pitch p (mm)	Chain width				Accumulation roller		
		B (mm)	b (mm)	$b_4$ (mm)	e (mm)	Diameter (mm)	Loading capacity per roller (kg)	Weight (kg/m)
<b>Design VR: Version with offset accumulation rollers</b>								
L 88 SFK-ML	12.70	27	9.2	14.50	18.70	16.00	6	0.85
L 88 SFS-ML	12.70	27	9.2	14.50	18.70	16.00	8	1.40
M 120 SFK-ML	19.05	40	11.70	19.55	29.0	24.0 / 26.0 / 27.0 / 28.0	10	1.8
M 120 SFK-ML	19.05	45	11.70	19.55	31.5	24.0 / 26.0 / 27.0 / 28.0	10	1.8
M 120 SFS-ML	19.05	40	11.70	19.55	29.0	24.0 / 26.0 / 27.0 / 28.0	15	2.8
M 120 SFS-ML	19.05	45	11.70	19.55	31.5	24.0 / 26.0 / 27.0 / 28.0	15	2.8

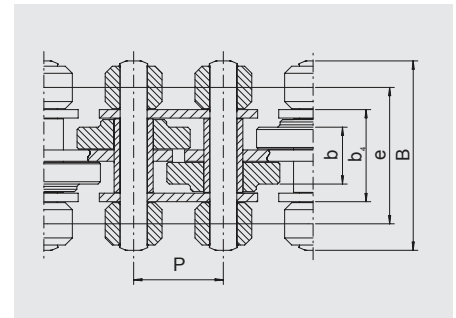

SFK – with plastic conveyor rollers SFS – with hardened steel conveyor rollers or with a choice of hardened steel or V2A conveyor rollers

iwis reference	Pitch p (mm)	Chain width B (mm)	e (mm)	$b_1$ (mm)	$b_2$ (mm) max.	$b_4$ (mm) max.	Width b (mm)	Accumulation roller			Diameter			
								Diameter	Loading capacity per roller (kg)	Roller $d_1$ (mm)	Pin $d_2$ (mm)	Weight (kg/m)		
<b>Design OS: Standard version without washers</b>														
L85 SFK-ML	12.7	27	18.7	7.75	11.3	14.5	7.55	–	16	17	6	8.51	4.45	0.802
L85 SFS-ML	12.7	27	18.7	7.75	11.3	14.5	7.55	–	16	17	8	8.51	4.45	1.223
M 127 SFK-ML	19.05	40	27.5	11.75	15.62	19.55	11.0	24.0	26.0	28.0	10	12.07	5.72	2.3
M 127 SFS-ML	19.05	40	27.5	11.75	15.62	19.55	11.0	24.0	26.0	28.0	15	12.07	5.72	3.1
<b>Design M: Standard version with side-mounted washers</b>														
M 127 SFK-ML	19.05	40	27.5	11.75	15.62	19.55	11.0	24.0	26.0	28.0	10	12.07	5.72	2.3
M 127 SFK-ML	19.05	43	29.0	11.75	15.62	19.55	11.0	24.0	26.0	28.0	10	12.07	5.72	2.3
M 127 SFK-ML	19.05	48	31.5	11.75	15.62	19.55	11.0	24.0	26.0	28.0	10	12.07	5.72	2.3
M 127 SFS-ML	19.05	40	27.5	11.75	15.62	19.55	11.0	24.0	26.0	28.0	15	12.07	5.72	3.1
M 127 SFS-ML	19.05	43	29.0	11.75	15.62	19.55	11.0	24.0	26.0	28.0	15	12.07	5.72	3.1
M 127 SFS-ML	19.05	48	31.5	11.75	15.62	19.55	11.0	24.0	26.0	28.0	15	12.07	5.72	3.1

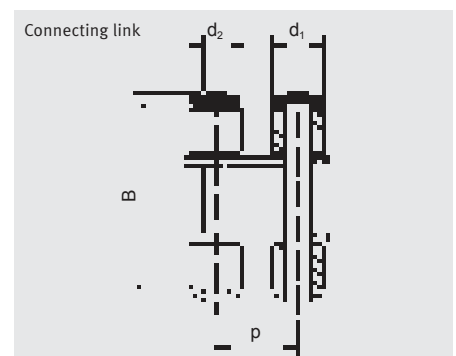
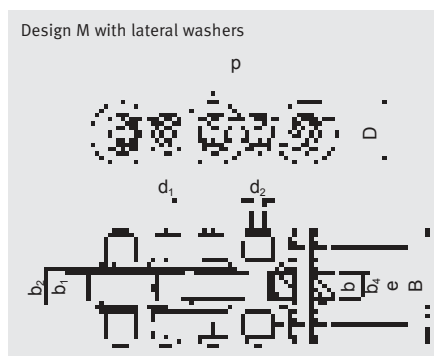
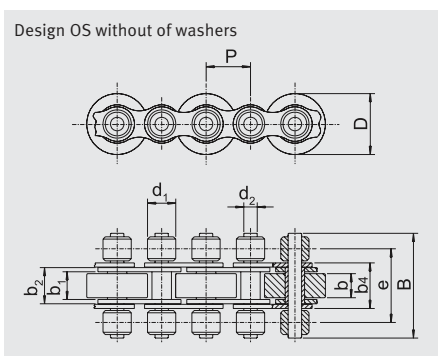

## iwis® Accumulation Chains with offset accumulation rollers

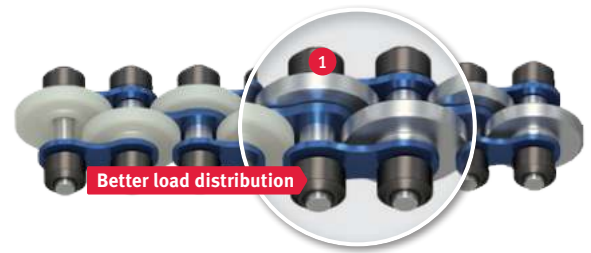

### PROBLEM/INITIAL SITUATION

- Simple and reliable transport of a very wide range of workpieces and workpiece carriers
- Continuous conveying, accumulating, singling out and acceleration

### OUR SOLUTION

This exclusive iwis accumulation chain generation has offset accumulation rollers on each pin, rather than a single wide roller on every second pin. As a result, each pin has a load-bearing function and transfers this load to twice as many rollers. This, has an extremely positive effect on chain guides.

### HIGHLIGHTS

- 1 Offset arrangement of the accumulation rollers ensures **optimised load distribution, better support** and **smoother running of the conveyed material**.
- 2 Offset arrangement of the accumulation rollers **reduces local load** on the chain guide by **50%**, for example, plastic guides can be used for up to double the load.

### HIGHLIGHTS

- Gentle transportation and optimum support for the material being conveyed
- In accumulating operation, roller friction only (see figure below)

- The newly developed **"light running rollers"** lead to a high reduction of drive power.

### COMPARISON OF FRICTIONAL FORCE

Chain with:

**iwis low-friction rollers**

classic idler rollers

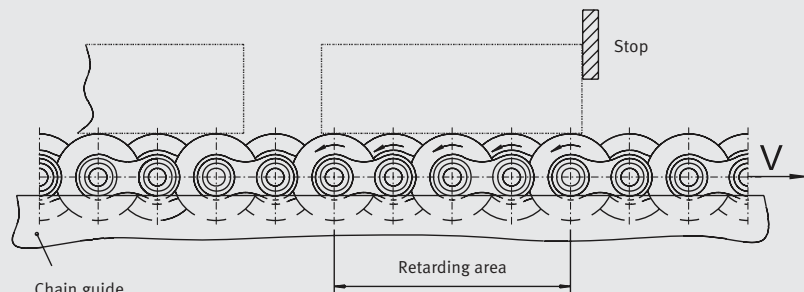
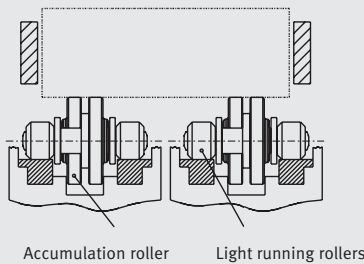

- Positioning the material transported with ease due to simple mounting points
- Chain no longer starts and stops jerkily
- Twice the transport speed is possible due to a simple acceleration rail (see figure below)

- Accumulation rollers made of hardened, stainless or nickel-plated steel, or plastic (also antistatic)
- The outside of the chain is clean because only the articulated points are lubricated

- Fully compatible with existing guides, deflector units and chain wheels
- Low-maintenance due to special wax lubrication (standard)
- Other initial lubrication for special applications on request

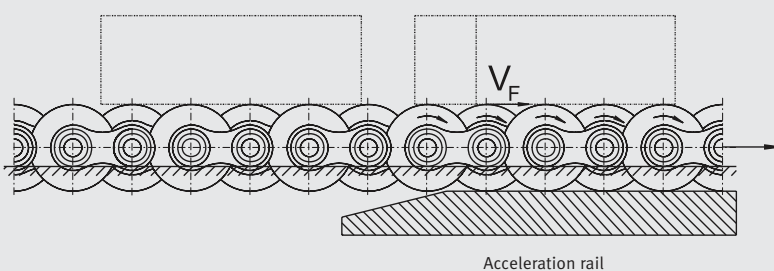



### ADDITIONAL ADVANTAGES

- Optimum load distribution – each pin bears load  
→ figure ① and ②
- Better support and smoother running of the conveyed material due to the accumulation rollers having an offset arrangement  
→ figures ③ and ④

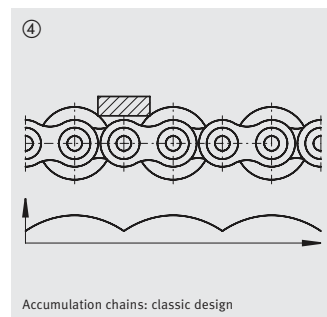
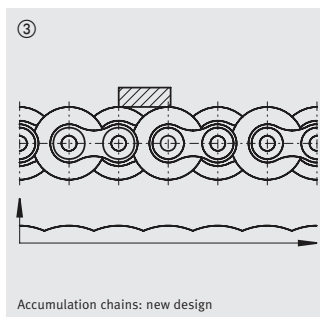
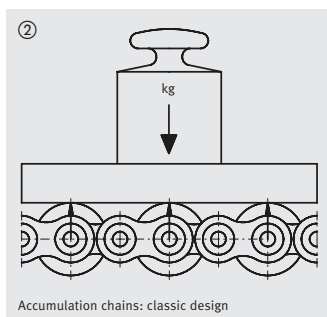
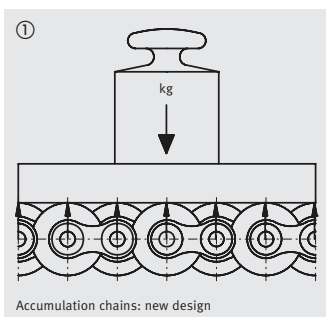

iwis reference	Pitch p (mm)	Chain width				Accumulation roller		
		B (mm)	b (mm)	b <sub>4</sub> (mm)	e (mm)	Diameter (mm)	Loading capacity per roller (kg)	Weight (kg/m)
<b>Accumulation Chains with offset accumulation rollers</b>								
L 88 SFK	12.70	27	9.2	14.50	18.70	16.00 <sup>1)</sup>	6	0.85
L 88 SFS	12.70	27	9.2	14.50	18.70	16.00 <sup>1)</sup>	8	1.40
M 120 SFK	19.05	40	11.70	19.55	29.0	24.0 <sup>1)</sup> / 26.0 / 27.0 <sup>1)</sup> / 28.0	10	1.8
M 120 SFK	19.05	45	11.70	19.55	31.5	24.0 / 26.0 / 27.0 / 28.0	10	1.8
M 120 SFS	19.05	40	11.70	19.55	29.0	24.0 <sup>1)</sup> / 26.0 / 27.0 <sup>1)</sup> / 28.0	15	2.8
M 120 SFS	19.05	45	11.70	19.55	31.5	24.0 / 26.0 / 27.0 / 28.0	15	2.8

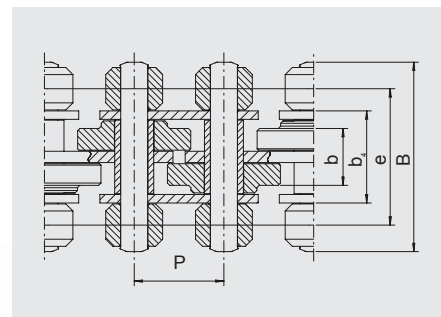

<sup>1)</sup> Supplied ex stock

SFK – with plastic accumulation rollers SFS – with hardened steel accumulation rollers

**30%** more efficient with iwis low-friction rollers

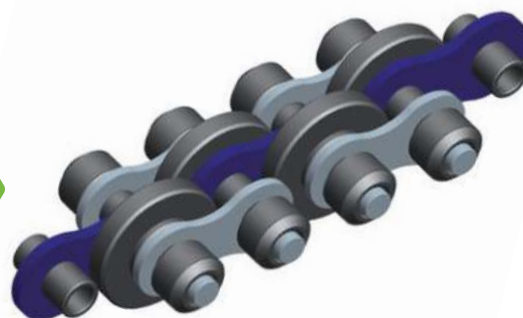

## JWIS® Standard Accumulation Chains

Easier, more reliable conveying of workpiece carriers



### PROBLEM/INITIAL SITUATION

- Simple and reliable transport of a very wide range of workpieces and workpiece carriers
- Continuous conveying, accumulating, singling out and acceleration

### OUR SOLUTION

JWIS brand accumulation chains have support rollers on both sides that serve two purposes: firstly, they engage with the sprocket teeth to transmit power, and secondly, they support the chain in the profile.

One special feature are the slightly protruding bushes in the inner link **1** which prevent contact corrosion between inner link and outer plate.

### ++ EXKLUSIVE ++

All 1/2" and 3/4" JWIS accumulation chains are fitted with low-friction sintered metal rollers **2** that provide **consistent and extreme light running** and are not slowed down by lubricant. The length of our application conveyor can therefore be built about **30% longer** without any need for modification of the drive motors; alternatively, if the system length remains unchanged, smaller drive units may be fitted. Less strain on the chain and drive means **a longer service life for the entire conveyor system.**

### HIGHLIGHTS

- Gentle transportation and optimum support for the material being conveyed
- In accumulating operation, roller friction only (see figure below)
- The newly developed **"light running rollers"** lead to a high reduction of drive power.

### COMPARISON OF FRICTIONAL FORCE

Chain with:

**iwis low-friction rollers**

classic support rollers



### IPW-LUBRICATED IWIS ACCUMULATION CHAINS



Pinpoint lubrication of bushes inside and outside

**DID YOU KNOW?**

**What is special about our IPW-lubricated JWIS® accumulation chains:**

iwis accumulation chains are lubricated by means of an inline process during their manufacture. Exactly the right quantity of lubricant is applied with pinpoint accuracy to each chain bearing. Unlike other chains on the market, JWIS accumulation chains are not immersed in oil, which offers the following advantages:

### HIGHLIGHTS

- iwis accumulation chains are dry on the outside
- Conveyed goods do not come into contact with lubricant
- No risk of over-lubrication, so no oil can splash or drip in sensitive areas
- Surrounding area is guaranteed to stay clean
- No dirt, particles, fibres or dust can adhere to the chain.

iwis reference	Pitch p (mm)	Chain width B (mm)	e (mm)	b <sub>1</sub> (mm)	b <sub>2</sub> (mm)	b <sub>4</sub> (mm)	Width b (mm)	Accumulation roller			Diameter			
								Diameter	Loading capacity per roller (kg)	Roller d <sub>1</sub> (mm)	Pin d <sub>2</sub> (mm)	Weight (kg/m)		
<b>Design OS: Standard version without washers</b>														
L85 SFK	12.7	27	18.7	7.75	11.35	14.5	7.55	-	16	-	6	8.51	4.45	0.802
L85 SFS	12.7	27	18.7	7.75	11.35	14.5	7.55	-	16	-	8	8.51	4.45	1.223
M 127 SFK	19.05	40	27.5	11.75	15.62	19.55	11.0	24.0	26.0	28.0	10	12.07	5.72	1.550
M 127 SFS	19.05	40	27.5	11.75	15.62	19.55	11.0	24.0	26.0	28.0 <sup>1)</sup>	15	12.07	5.72	2.592
<b>Design M: Standard version</b>														
M 127 SFK <sup>2)</sup>	19.05	40	27.5	11.75	15.62	19.55	11.0	24.0	26.0	28.0	10	12.07	5.72	1.742
M 127 SFK	19.05	43	29.0	11.75	15.62	19.55	11.0	24.0	26.0 <sup>1)</sup>	28.0	10	12.07	5.72	1.646
M 127 SFK	19.05	48	31.5	11.75	15.62	19.55	11.0	24.0	26.0	28.0	10	12.07	5.72	1.920
M 127 SFS <sup>2)</sup>	19.05	40	27.5	11.75	15.62	19.55	11.0	24.0	26.0	28.0	15	12.07	5.72	2.688
M 127 SFS	19.05	43	29.0	11.75	15.62	19.55	11.0	24.0	26.0 <sup>1)</sup>	28.0	15	12.07	5.72	2.688
M 127 SFS	19.05	48	31.5	11.75	15.62	19.55	11.0	24.0 <sup>1)</sup>	26.0	28.0	15	12.07	5.72	2.880
M 1611 SFK <sup>2)</sup>	25.4	65	44.9	17.02	25.45	32.0	16.5	38.5	-	-	25	15.88	8.28	4.104
M 1611 SFS <sup>2)</sup>	25.4	65	44.9	17.02	25.45	32.0	16.5	38.5	-	-	30	15.88	8.28	6.552
D 1611 SFS <sup>2)</sup>	25.4	99	76.9	17.02	25.45	63.4	16.5	38.5	-	-	30	15.88	8.28	11.584
<b>Design LR: Double-pitch version</b>														
LR 165 SFK <sup>2)</sup>	25.4	30.7	20.0	7.75	11.30	14.65	7.5	24.0	-	-	6	8.52	4.45	0.792
LR 247 SFK	38.1	48	31.5	11.75	15.62	19.55	11.0	24.0	35	-	10	12.07	5.72	1.200
LR 247 SFS	38.1	48	31.5	11.75	15.62	19.55	11.0	24.0	35	-	15	12.07	5.72	2.016
LR 3211 SFK <sup>2)</sup>	50.8	67.9	44.9	17.02	25.45	32.0	16.5	50.0	38.5	-	25	15.88	8.28	2.764
LR 3211 SFS <sup>2)</sup>	50.8	67.9	44.9	17.02	25.45	32.0	16.5	50.0	38.5	-	30	15.88	8.28	5.236

<sup>1)</sup> Supplied ex stock <sup>2)</sup> Chains without light running rollers  
SFK – with plastic conveyor rollers SFS – with hardened steel conveyor rollers

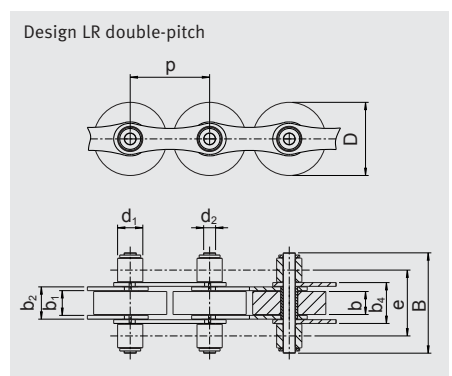
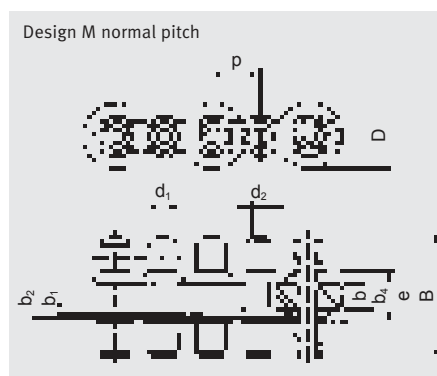
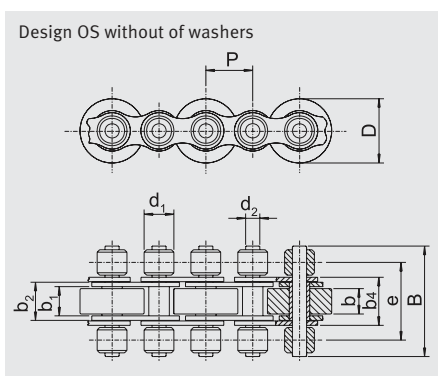
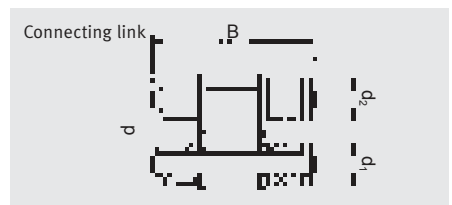

## **iwis** *b.smart* Accumulation Chains

Optimum transportation of conveyed goods



### PROBLEM/INITIAL SITUATION

- Simple and reliable transport of a very wide range of workpieces and workpiece carriers
- Continuous conveying, accumulating, singling out and acceleration

### KNOW-HOW MEETS EFFICIENCY

Put robust, durable **b.smart** accumulation chains to work for you – proven **iwis** quality at an attractive price!

Designed for cost-optimised conveyor technology applications – developed for optimum transportation of conveyed goods.

### OPTIMUM RELUBRICATION

The service life of a chain depends on correct and adequate relubrication. After a certain time, which may vary according to operating conditions, the lubricant applied originally is eventually used up due to the oscillating motion of the chain bearing. Inadequate lubrication causes boundary friction, which in turn leads to fretting corrosion and increased chain wear. Selection of the correct lubricant and lubrication method are therefore a decisive factor in assuring that the relubrication process is effective.

## **iwis** Accumulation Chains with finger and small parts protection

Absolutely safe

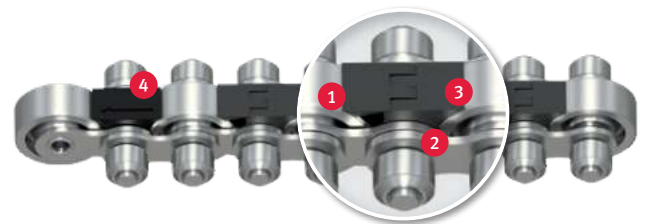

### PROBLEM/INITIAL SITUATION

- Simple and reliable transport of a very wide range of workpieces and workpiece carriers
- Continuous conveying, accumulating, singling out and acceleration

### OUR SOLUTION

Accumulation chains with finger and small parts protection feature optimum cover of the space between one accumulation roller and the next, preventing the ingress of small parts that could jam the rollers and/or chain link. In addition, the cover prevents the deliberate or accidental insertion of fingers while the conveyor is operating – an active contribution to accident prevention in line with increasingly strict industrial safety requirements.

### SAFETY FOR OPERATORS & MACHINES

- 1 100% cover of the space between accumulation rollers in accordance with required bend radii of the selected chain type
- 2 Firm mounting of plastic clip on inner link
- 3 No abrasive strain on conveyed goods, workpiece carriers or accumulation rollers
- 4 Two different finger protection versions – with and without joint



## **iwis® Side Bow Accumulation Chains**

Ideal for conveyor systems with extremely small curve radii



### OUR SOLUTION

L 88 SF SB and M 120 SF-SB design – **the solution** for modular changes of direction in conveyor systems

### HIGHLIGHTS

iwis Side bow accumulation chain with offset rollers **1**: The modular solution for direction changes in conveyor systems with extremely tight bend radii (**> 350 mm**).

Optimum load distribution as transported material lies flat on links **2** even in bends, thus reducing chain wear.

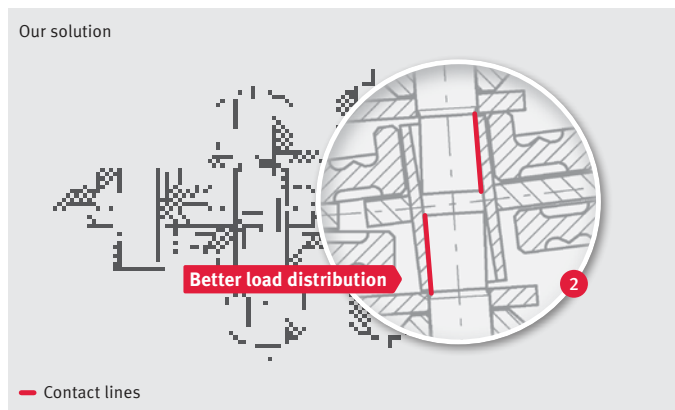
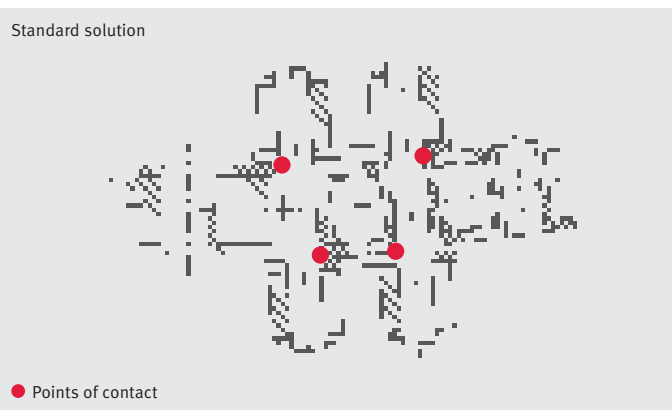

iwis reference	Pitch p (mm)	Chain width				Accumulation roller			
		B (mm)	b (mm)	b <sub>s</sub> (mm)	e (mm)	Diameter D (mm)	Loading capacity per roller (kg)	Weight (kg)	
<b>Side Bow Accumulation Chains</b>									
L 88 SFS-SB	12.70	27	9.2	15.0	18.70	16.00	8	1.40	
L 88 SFK-SB	12.70	27	9.2	15.0	18.70	16.00	8	1.40	
M 120 SFK-SB	19.05	40	11.70	20.10	29.0	24.0 / 26.0 / 27.0 / 28.0	10	1.8	
M 120 SFS-SB	19.05	40	11.70	20.10	29.0	24.0 / 26.0 / 27.0 / 28.0	15	2.8	

Connecting link dimensions vary

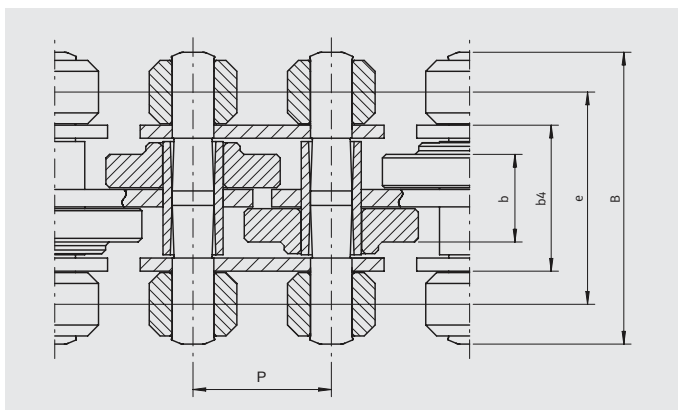

## iwis® Accumulation Chains

### Important information

#### MAINTENANCE GUIDE FOR ACCUMULATION CHAINS

As for every roller chain, the „bearing points“ of the accumulation chain are also subject to natural wear. The correct tension, good guidance and effective relubrication are needed to reduce this and therefore increase the service life of the chain.

An accumulation chain works perfectly at up to 2% extension caused by wear with the provision that it is constantly retensioned. Approximately 5% of the actual chain tensioning force occurring can be used as a guide value for pretensioning.

Accumulation chains are given extremely effective initial lubrication in the works. The lubricant is used up in the course of time and effective and regular relubrication is necessary. During this process, care must be taken that the lubrication is undertaken at the correct points (= bearing points) and that the lubricant is able to creep.

#### INFORMATION ON THE DESIGN OF ACCUMULATION CHAINS

Important criteria when selecting an accumulation chain are:

- Loading on the accumulation rollers from the weight of the material being conveyed on them. The load-bearing strength per roller is stated in the tables. If the contact surface for the material being conveyed is uneven, it is necessary to estimate how many free rollers are actually load-bearing.
- Loading on the chain from tensile forces occurring in operation. The most important influencing dimensions are the weight of the material conveyed and the friction factors. The following tensile forces occur in accumulation chains:
  - from friction resistance between roller and chain pin
  - from friction resistance between accumulation rollers and chain bush when in accumulating operation
  - from roller resistance when rolling the runners on to the chain guides and when rolling the conveyed materials on to the accumulation rollers.

Rough determination of the chain tensioning force  $F$  per chain strand:

$$F = \frac{\mu \cdot 9.81 \cdot Q \cdot 1.4}{n} \text{ [N]}$$

$\mu$  = friction value 0.08-0.3 depending on:

- material pairing  
Steel/steel or plastic/steel
- Condition of the friction surfaces:  
dry or lubricated
- Degree of contamination of the friction surfaces

$Q$  = Total weight conveyed [kg]

$n$  = Number of chain strands

The formula is valid for even distribution of the weight loading over the chain strands. If the conveyed material is not in full contact because of unevenness, an estimate has to be made as to what percentage of the length in contact is actually effective. The tensile strength per chain strand is correspondingly higher.

#### MAX. CONVEYOR LENGTH

Depending on loading 25 – 30 m, parallel and exact guidance must be ensured.

#### AREA OF USE...

... of accumulation chains:

- In many areas of conveyor engineering
- Where there are links in processing and assembly lines
- In warehouse engineering
- In a wide range of material flow systems

... and everywhere where work-pieces, components for storage, pallets, containers, crates etc. have to be conveyed, accumulated, accelerated and singled out in a simple way.

#### RECOMMENDED WORKING LOAD

iwis chain	Recommended max. working load [N]
L 88 SF	1500
L 85 SF	2300
M 120 SF	2500
M 127 SF	4000
M 1611 SF	5000
D 1611 SF	10000

## **iwis**® Accumulation Chains Accessories

### CHAIN SPROCKETS FOR ACCUMULATION CHAINS

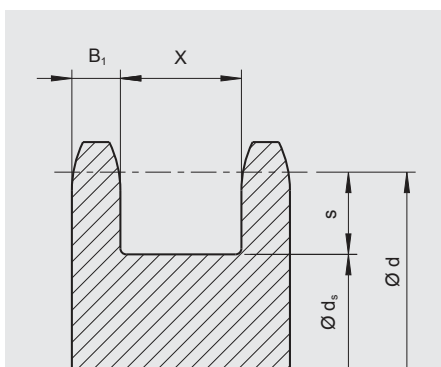

iwis reference	Pitch p (mm)	B <sub>1</sub> (mm)	X (mm)	s (mm)
L 88 SF	12.7	4	15.5	10
M 120 SF-B40	19.05	8.3	20,7	15.0
M 127 SF-B40/B43	19.05	8.3	20.7	15.0
M 120 SF-B45	19.05	10.8	20.7	15.0
M 127 SF-B48	19.05	10.8	20.7	15.0
M 1611 SF	25.4	11.6	33.3	20.5

$d_s = d - 2s$   $d = p : (\sin 180^\circ : z)$  Recommended number of teeth minimum  $z = 15$

### CHAIN GUIDE/EXAMPLE

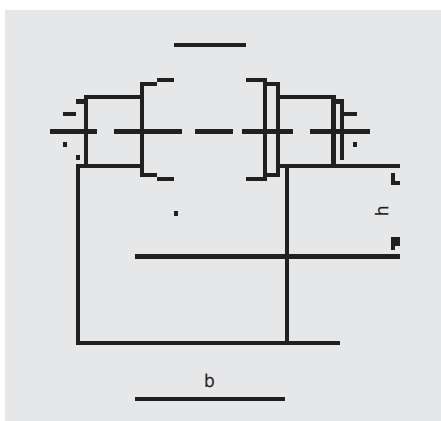

iwis chain	b (mm)	h (mm)
L 88 SF	15	10
L 88 SF SB	15.5	10
M 120 SF	20	15
M 120 SF SB	21	15
M 127 SF	20	15
M 1611 SF	33	20

### TOOL



#### ARTICLE NO. 40000646

Tool for dismantling accumulation chain M 120 SF and M 127 SF with 3/4 inch pitch (available from stock)

### CLEANING BRUSHES FOR PROFILES

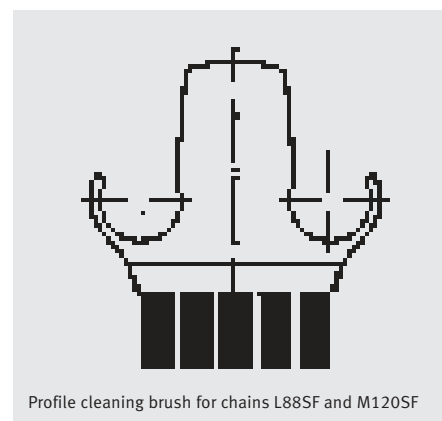

Profile cleaning brush for chains L88SF and M120SF

iwis has two types of multipurpose brushes especially designed to clean conveying profiles for most stringent conditions (for example: chips, welding drops, dust etc.).



Brush for chains L85SF und M127SF. Other chain types types on request.



# Special Conveyor Chains

iwis offers an extensive program of special chains for various industrial applications and requirements. While the plate chain is being used wherever smooth and reliable conveying through very narrow bends is necessary, the transfer chains are utilized wherever gentle transportation is required. iwis grip chains are applied wherever plate and sheet type materials are drawn in or off, transported or positioned. Additional iwis special conveyor chains: tube and can transport chains (POC), pallet transporting chains, side bow chains, leaf chains, push pull chains and hollow pin chains.







## **iwis**® Grip Chains

Safe infeeding, transportation and positioning of thin-walled, large-area soft foils and panels

### PRODUCT RANGE



Design A  
With 1 tip

Design B  
With 2 tips

Design C  
With flat clamps

Design D  
With button clamps

Design E  
With clamp E

Design F  
With clamp F

### HIGHLIGHTS

- iwis high-performance chains with excellent wear resistance
- Minimal initial elongation due to optimum pre-stretching
- High rigidity also enables applications in long machines
- Basic chain versions are chemically nickel-plated / MEGAlife maintenance-free versions are available on request
- Identical chain lengths (within the selected tolerance range) ensure excellent running characteristics in both synchronous and parallel operation
- Differing levels of spring force allow an extremely wide range of materials to be gripped gently and held securely
- Chains with restricted length tolerances can be produced
- Recommended maximum running speed:
  - 2 m/s for the 1/2" grip chain
  - 1,2 m/s for the 5/8" grip chain
 Different control geometry is required for higher running speeds.
- iwis provides complete, ready-to-install solutions!

### FLYER

See our product flyer for more information.



All chains can be supplied with a high-quality **food-grade** initial lubricant!

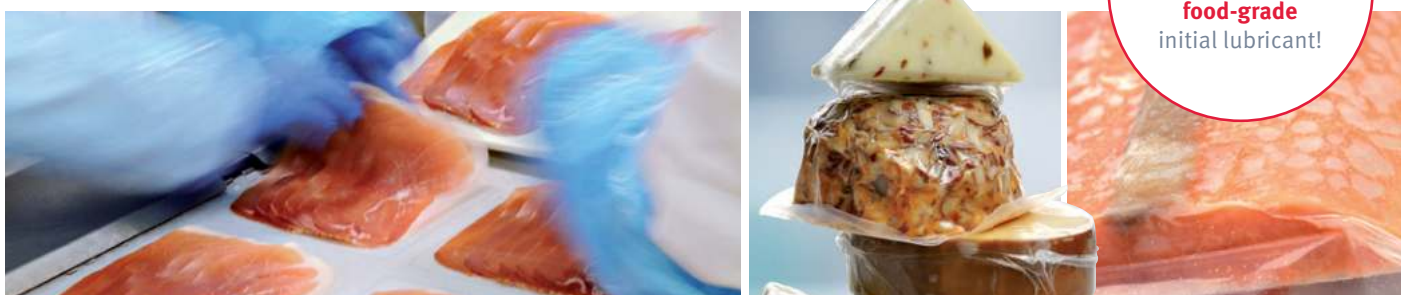

## THE NEW IWIS GRIP CHAIN

Version E



**i** For more technical details, see p. 90

### CURRENT SOLUTION

- Not enough space to insert film
- Applying force only to individual points in the foil can cause the film to tear, which also results in increased noise.
- Foil deformation possible at the edge of the gripper element

### OUR SOLUTION

- Accurate fitting of gripper in the groove
- Better retention force than the competition
- Retention force dependent on plastic film used
- Burled plate for optimized functional safety and hygiene
- More free space for better foil insertion
- Films are not twisted, no deformation at the edge of the gripper element
- Lower noise emissions
- Easier removal of foil scraps at the line outfeed

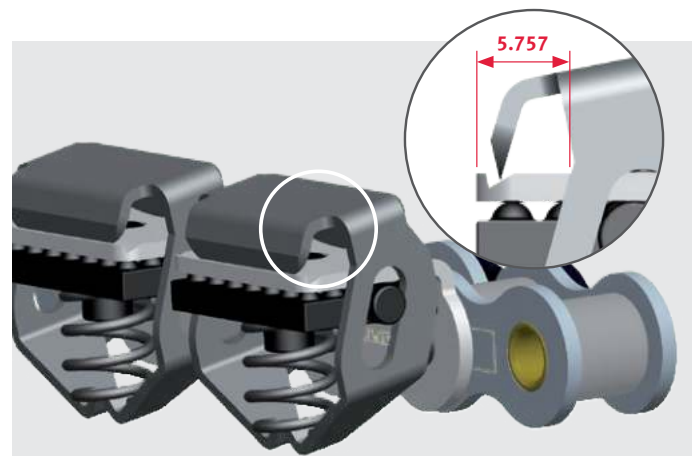
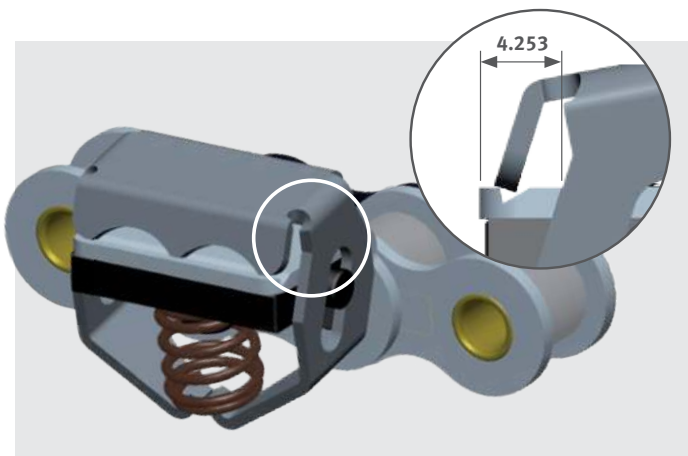

## iwis® Grip Chains

Safe infeeding, transportation and positioning of thin-walled, large-area soft foils and panels

### “1-TIP” GRIP CHAINS



### “2-TIP” GRIP CHAINS



### TECHNICAL FEATURES

- Simplex and duplex chain 1/2 x 5/16“ acc. to ISO 606
- Gripper with 1 tip, special designs on request
- Retention force is dependent on material conveyed and spring design – different number of coils and wire spring diameters available
- The gripper opens when it runs against a control disc (e.g. sprocket hub), causing it to swivel away outwards
- Food-grade initial lubrication
- Sprocket designs on request

### TECHNICAL FEATURES

- Simplex and duplex chain 1/2 x 5/16“ acc. to ISO 606
- Gripper with 2 tips, special designs on request
- Retention force is dependent on material conveyed and spring design – different number of coils and wire spring diameters available
- The gripper opens when it runs against a control disc (e.g. sprocket hub), causing it to swivel away outwards
- Higher retention force in comparison with 1-tip grip chain
- Food-grade initial lubrication
- Sprocket designs on request

iwis reference	DIN ISO	Pitch p [mm]	Average foil retention force $F^*$ [N]	Spring	x	y	Article No.
L 85 Grip	08 B-1	12.7	10	0.7 x 6	5	6	50007495
L 85 Grip	08 B-1	12.7	24	0.9 x 5	4	5	50034722
D 85 Grip	08 B-2	12.7	10	0.7 x 6	5	6	50007033

iwis reference	DIN ISO	Pitch p [mm]	Average foil retention force $F^*$ [N]	x	y	Article No.
L 85 Grip	08 B-1	12.7	35	3.0	4.5	50024958

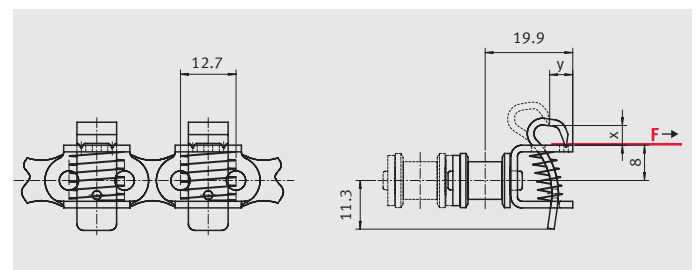
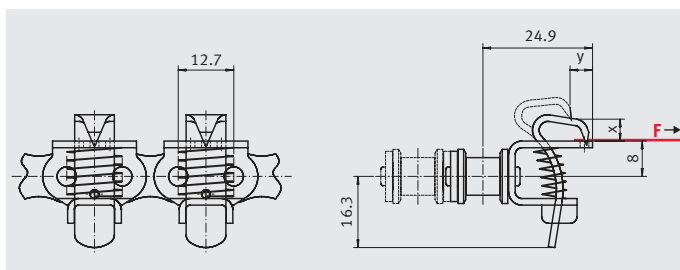

Dimensions x and y are dependent on the springs used. These are maximum values for the opening stroke. A smaller opening stroke will increase life expectancy of the spring.

\* Reference foils were used to determine the average foil gripping force (F).

Concrete values are dependent on the film used (material, surface, thickness). Deviations are possible.

**“FLAT CLAMP” GRIP CHAINS**

**“BUTTON CLAMP” GRIP CHAINS**



**TECHNICAL FEATURES**

**TECHNICAL FEATURES**

- **Simplex and duplex chain** 1/2 x 5/16“ acc. to ISO 606
- Gripper with flat clamping surface
- Retention force is dependent on material conveyed and spring design – different number of coils and wire spring diameters available
- The gripper opens when it runs against a control disc (e.g. sprocket hub), causing it to swivel away outwards
- Gentle handling of materials
- Low transmission forces
- Sprocket designs on request
- Can also be used for paper

- **Simplex chain** 1/2 x 5/16“ or 5/8 x 3/8“ acc. to ISO 606
- Rotationally symmetrical gripper element
- Extremely flat button clamp
- Retention force is dependent on material conveyed and spring design – different number of coils and wire spring diameters available
- **iwis patent** (spring without additional fixing elements)
- Does not swivel away outwards when opened
- Sprocket designs on request

iwis reference	DIN ISO	Pitch p [mm]	Average foil retention force F* [N]	Spring	x	y	Article No.
L 85 Grip	08 B-1	12.7	3	0.7 x 6	5	3.5	50037062
L 85 Grip	08 B-1	12.7	5	0.9 x 5	4	2.8	50035540
D 85 Grip	08 B-2	12.7	3	0.7 x 6	5	3.5	50032581

iwis reference	DIN ISO	Pitch p [mm]	Average foil retention force F* [N]	e	Article No.
M 106 Grip	10 B-1	15.875	70	16.8	50034301
L 85 Grip	08 B-1	12.7	70	15.8	50035491

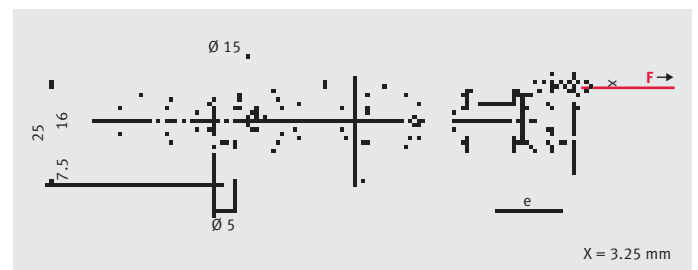
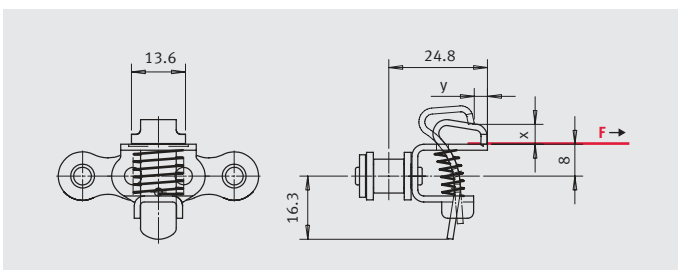

Dimensions x and y are dependent on the springs used. These are maximum values for the opening stroke. A smaller opening stroke will increase life expectancy of the spring.  
\* Reference foils were used to determine the average foil gripping force (F).  
Concrete values are dependent on the film used (material, surface, thickness). Deviations are possible.

## iwis® Grip Chains

Safe infeeding, transportation and positioning of thin-walled, large-area soft foils and panels

### GRIP CHAIN WITH CLAMP E



### GRIP CHAIN WITH CLAMP F



### TECHNICAL FEATURES

- Optimization of grip chain M106 with attachment 202.6 on one side and delivery as a complete solution with gripper system consisting of clamp, burled plate and spring
- Clamp and spring made of corrosion-resistant steel
- Chain is chemically nickel-plated
- Available with long-lasting lubrication or food-grade lubricant
- Alternative: M106 standard chain also available without attachments (Customers' own clamps can be fitted)
- Springs with optimised surface structure

iwis reference	ISO	Pitch p [mm]	Average foil retention force F* [N]	x	y	Length	Article No.
M 106 Grip	10 B-1	15.875	85	4.9	6.1	5 m	50040658
M 106 Grip	10 B-1	15.875	85	4.9	6.1	50 m	50039260

### TECHNICAL FEATURES

- **Single and duplex chain 1/2 x 5/16"** acc. to ISO 606
- Complete gripper element
- Gripper element with a continuous sharp-aged gripping flange
- Retention force is dependent on material conveyed
- Clamp and spring made of stainless steel spring steel
- Due to a special geometry of sprockets used, the gripper opens with a slight sideways movement
- Food-grade initial lubrication
- Sprocket designs on request

iwis reference	ISO	Pitch p [mm]	Average foil retention force F* [N]	Spring	x	y	Article No.
L 85 Grip	08 B-1	12.7	42	1.3 x 5.5	3	0.6	50045980

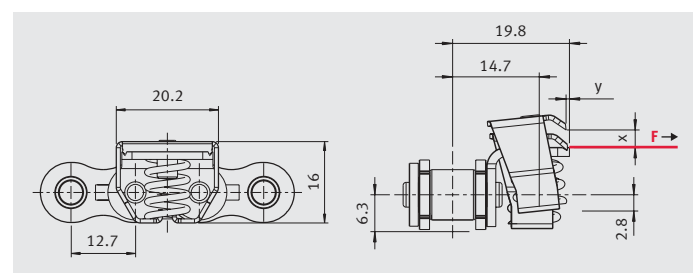
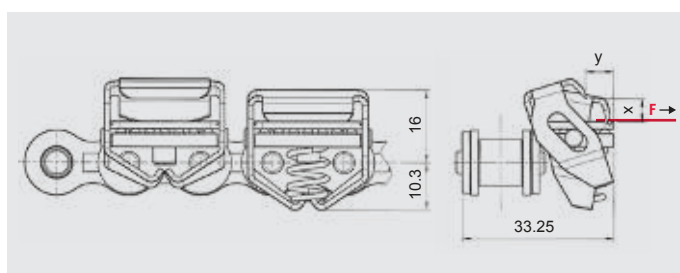

Dimensions x and y are dependent on the springs used. These are maximum values for the opening stroke. A smaller opening stroke will increase life expectancy of the spring.

\* Reference films were used to determine the average film gripping force (F).

Concrete values are dependent on the film used (material, surface, thickness). Deviations are possible.

## **iwis**® Tube Conveyor Chains

Gentle support and reliable transportation for thin-walled hollow bodies

### PROBLEM/INITIAL SITUATION

Gentle support and reliable transportation for thin-walled hollow bodies through several processing stations (cleaning, painting, drying...).

### OUR SOLUTION

iwis high-performance chains – roller chains with corrosion-resistant, easy to change attachments. **Exclusive to iwis.**



### HIGHLIGHTS

- Transport bars can be changed easily on site using the special iwis tool provided; no need to break the chain or remove it from the machine
- Adapter and bars made of highly alloyed, corrosion-resistant steels with good elastic characteristics
- iwis standard roller chains with particular wear-resistant SL-pins are used, so longer service life in comparison with hollow pin chains
- Transport bars available in required lengths with 1 mm graduations
- Different shapes for bar ends available – for example protection heads made of aluminium or plastic
- Freely selectable distance between the bars
- Basic chains also available in maintenance-free version (MEGAlife)
- 1/2", 5/8" und 3/4" also available in curved side design (only ANSI)

### TECHNICAL FEATURES

- The bars are pinched on to the extended pins of the base chain using an adapter and secured by fins to prevent twisting
  - The bar can be changed quickly and easily if repairs are necessary by breaking open the adapter with the iwis special tool (see illustration)
- i** Suitable tool for mounting and removal can be supplied.

### AREAS OF APPLICATION

- Everywhere where tubes and other thin-walled hollow bodies (cans) are transported, cleaned, painted, dried...

**Inquiry form tube conveyor chains:**  
[www.iwis.de/  
tube-conveyor-chains-inquiry](http://www.iwis.de/tube-conveyor-chains-inquiry)

ISO	iwis reference	Pitch p (mm)	L max. (mm)	D <sub>1</sub> (mm)	m (mm)	D <sub>2</sub> (mm)	D <sub>3</sub> (mm)
08B-1	L 85 SL	12.7	300	8.0	22.0	4.0	8.0
10B-1	M 106 SL	15.875	300	8.0	22.0	4.0	8.0
12B-1	M 127 SL	19.05	300	8.0	22.0	4.0	8.0
12 A-1 ANSI 60	M 128 ASL	19.05	300	8.0	22.0	4.0	8.0

Please state the length L in any enquiry or order.

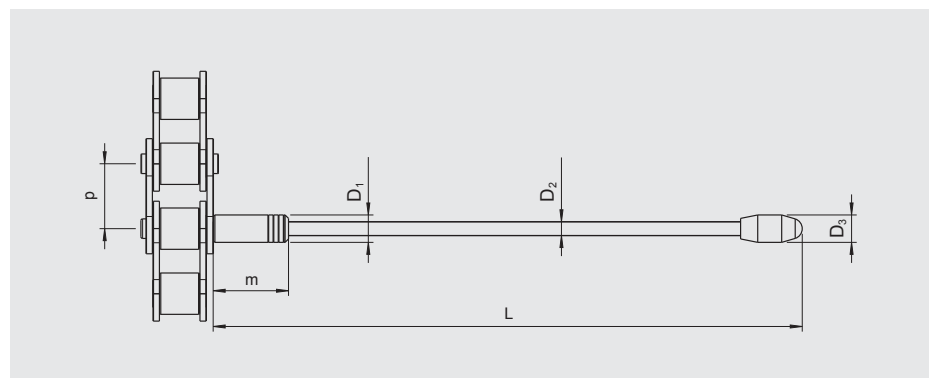
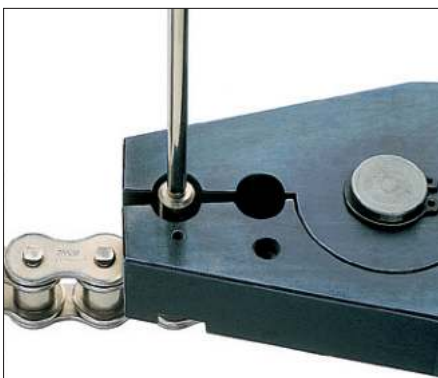

## iwis® Pin Oven Chains

The reliable and safe transport of cans

### PROBLEM/INITIAL SITUATION

The reliable and safe transport of cans or other thin-walled hollow bodies at high speeds and temperatures.

### OUR SOLUTION

iwis high-performance chains are extremely wear-resistant with specially adjusted transport pins and superior protective heads – the right solution for every 2-part can handling application!



### HIGHLIGHTS

- iwis precision roller chains are long-lasting, reliable and particularly wear resistant.
- iwis Pin Oven Chains for can manufacturing applications are initially treated with our special lubricant IPP. IPP is PWIS-free, drip-proof, has a very low evaporation rate, is suitable for high-temperature operation and approved for use in the food industry.
- **Standard protective head:** high-performance material (PEEK), outstandingly heat-resistant (up to at least 260 °C, depending on application). PEEK is also highly resistant to chemicals. Protective heads are also optionally available with sliding washers, if necessary (only recommended for applications where contamination is uncritical).
- Length of transport pins can be adapted to your specifications.
- Transport pins: easy to change on the production line without breaking the chain or removing it from the machine (POChain P/-S)

- Transport pins can be installed at defined intervals (e.g. every 7th pin).
- iwis offers three fixture options for transport pins:
  - POChain-I: pins are integrated in the outer chain plates
  - POChain-P: split-pin fixture
  - POChain-S: pins are secured with special nuts
- Temperature range: 0 °C to +260 °C

### AREAS OF APPLICATION

- Everywhere where cans or other thin-walled hollow bodies are transported, painted, dried...

**Inquiry form POChain:**  
[www.iwis.de/POChain-inquiry](http://www.iwis.de/POChain-inquiry)

### TWO PIN VERSIONS

**Bendable pin:** These pins are manufactured to be tough yet bendable enough to withstand inadvertent impact during conveyor jams or accidental contact with the machine frame. These pins are easy to bend back into their original position by hand.

**SnapOff pin:** The material specification of these pins cause them to break off in the event of any accidental contact or impact during operation. The advantage for you: the hardness of the transport pin material is similar to that of the pins of the base chain, so the wear rate of both sets of pins is the same.

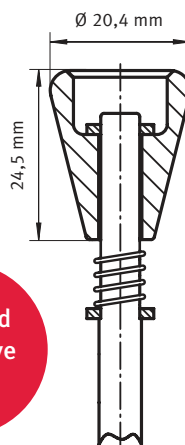

Standard protective head

### OUR FIXTURE SOLUTIONS

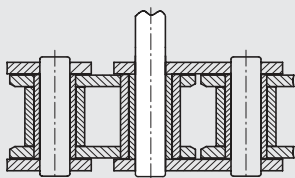

iwis POChain-I

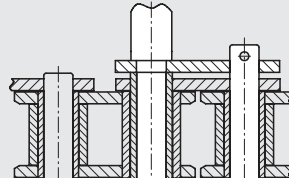

iwis POChain-P

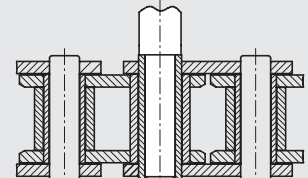

iwis POChain-S



Chain type	ISO	iwis designation	Pitch × inner width $p \times b_1$	Breaking load $F_b$ (N)	Roller $\varnothing$ $d_1$ max. (mm)	Hollow pin inner $\varnothing$ min. $D$ (mm)	Inner width $b_2$ min. (mm)	Pin length $b_4$ (mm)	Transport pin $\varnothing$ $T$ (mm)	Weight (dependent on transport pin length)
POChain-I	12 A-1/ANSI 60	M 128A SL	3/4 × 1/2"	31,300	11.91	–	12.7	26.3	5.97	approx. 1.9 kg/m
POChain-P	12 A-1/ANSI 60	M 128A SL	3/4 × 1/2"	31,300	11.91	6.0	12.7	26.7	5.97	approx. 1.9 kg/m
POChain-S	12 A-1/ANSI 60	M 128A SL	3/4 × 1/2"	31,300	11.91	6.0	12.7	26.7	8.00	approx. 2.3 kg/m

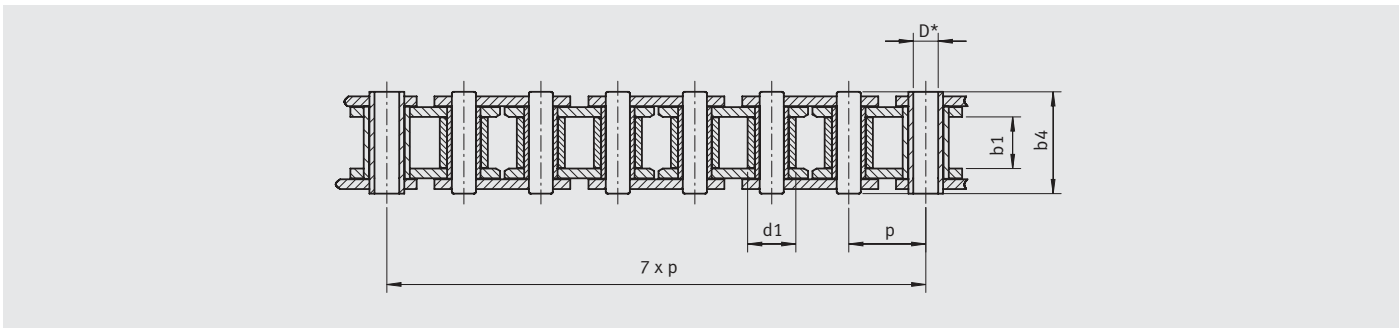

\*Notice: Dimensions only apply to POChain-P/S. K defines the dimension from outer plate to the end of the protective head.

### HIGHLIGHTS IWIS ELASTIC CAN TIP (ECT)

- Less complex design: one high-temperature elastomeric head replaces one PEEK protective head, three washers and a spring!
- The design and material properties of the elastomeric head take over the damping properties of a spring.
- Defective heads can be replaced easily and without tools.
- Even defective heads still have emergency running capabilities.
- ECT material is PWIS-free and FDA approved!
- Will not damage thin-walled drinks cans.
- Suitable for temperatures up to 215 °C. Available now!

New iwis head solutions for your special requirements:  
**innovative and patented**

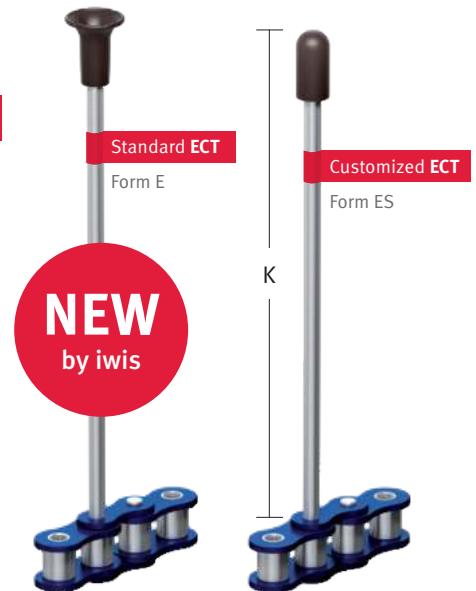

### NOMENCLATURE

Our precise nomenclature makes ordering easier for you. The detailed designation code helps you to find and order exactly the right chain for your application quickly and without any trouble – in writing, by phone or via our online request form.

1 2 3
4 5 6 7
8

60-M128A-ST-I-7-7.060-SO-P-S-322L-POChain

- |   |  |
|---|--|
| <ul style="list-style-type: none"> <li>1 [ST] Standard with IPP lubricant</li> <li>2 [I] Integral [P] Push-fit [S] Threaded</li> <li>3 Pin interval (every 7<sup>th</sup> pin)</li> <li>4 Pin length dimension K (4-digit in inches 4-digit in mm)</li> </ul> | <ul style="list-style-type: none"> <li>5 [SO] SnapOff pin [BE] Bendable pin</li> <li>6 [P] PEEK [E] Elastomeric standard ECT [ES] Customized elastomeric ECT</li> <li>7 [S] without loose-fit spacer [W] with loose-fit spacer</li> <li>8 Individual chain length (links)</li> </ul> |
|---|--|

[www.iwis.de/POChain-inquiry](http://www.iwis.de/POChain-inquiry)

## iwis® Push Pull Chains

Compact, flexible, strong!

Now even  
**BETTER!**

### PROBLEM/INITIAL SITUATION

- Restricted installation space
- Absorption and/or transmission of pressure forces in and perpendicular to running direction
- Deflection of pressure forces from any direction

### OUR SOLUTION

The compact design of iwis push pull chains makes them ideal for the transmission of both compressive and tensile forces – even without chain guides. Chain engineering for the tightest spaces.



### HIGHLIGHTS

- Push pull chains are only flexible in one direction
- Compact design for maximum functionality
- Suitable for pushing loads and bridging gaps without chain guides
- Conversion of translational tensile and compressive forces into rotational motion and vice versa
- Variety of material specifications can be supplied
- IWIS endpieces are the interface between push pull chain and traction/propulsion element; they create the chain pre-tensioning required.
  - Easy fitting with standard components
  - Individual interface available on request
- Stainless steel versions also available.

### ROTATIONAL, TRANSLATIONAL

- Push pull chains can perform the same functions as linear drives, so an endless, continuous chain drive is often no longer necessary.
- The side-bow and back-bend capabilities of push pull chains can be individually customised, which offers a wide range of versatile solutions.
- An added bonus of these chains is their extremely compact design, resulting in space savings of up to 60% – a significant cost factor.

### APPLICATIONS

- General mechanical engineering
- Medical technology
- Automotive engineering
- Conveyor systems
- Building services engineering
- Machine tools
- Ergonomic workplace design and furniture



Customized version EC16M-RS





iwis reference	Pitch $p$ (mm)	Roller diameter $d1$ max (mm)	Width between inner plates $b1$ min (mm)	Pin diameter $d2$ max (mm)	Pin length			Plate dimension			Max. compressive force <sup>2)</sup> $F_D$ max (kN)	Min. tensile strength $F_t$ (kN)	Weight $q$ (kg/m)
					$L$ max (mm)	$L_c$ max (mm)	$H$ (mm)	$h$ (mm)	$t/T$ max (mm)				
<b>Push Pull Chains</b>													
G52 RS <sup>1)</sup>	8.00	5.00	3.16	2.31	10.1	11.2	7.1	3.6	0.8	0.9	3.0	0.27	
G67 RS <sup>1)</sup>	9.525	6.35	5.72	3.31	15.7	16.9	8.2	4.1	1.2	1.8	6.5	0.55	
EC6M RS	9.525	5.08	4.80	3.58	13.2	15.2	13.5	9.0	1.3/2.0	1.5	6.0	0.73	
EC8M RS	12.70	7.92	7.90	3.98	17.2	19.2	17.1	11.0	1.5	3.5	13.0	1.02	
L85 RS <sup>1)</sup>	12.70	8.51	7.75	4.45	19.8	21.4	11.8	5.9	1.7/1.5	3.8	13.0	0.93	
M106 RS <sup>1)</sup>	15.875	10.16	9.65	5.08	22.8	24.2	14.4	7.2	1.7/1.6	5.7	16.0	1.56	
M128A RS	19.05	11.91	12.60	5.96	30.0	31.4	18.0	9.0	2.4	10.2	25.0	1.96	
M1610A RS	25.40	15.88	15.88	7.92	39.0	40.9	23.0	11.5	3.2/3.0	18.5	40.0	3.56	

<sup>1)</sup> The inner link dimensions of our push pull chains correspond to ISO 606. Smallest sprocket: 10 teeth.

<sup>2)</sup> Max. compressive force dependent on chain length and drive parameters.

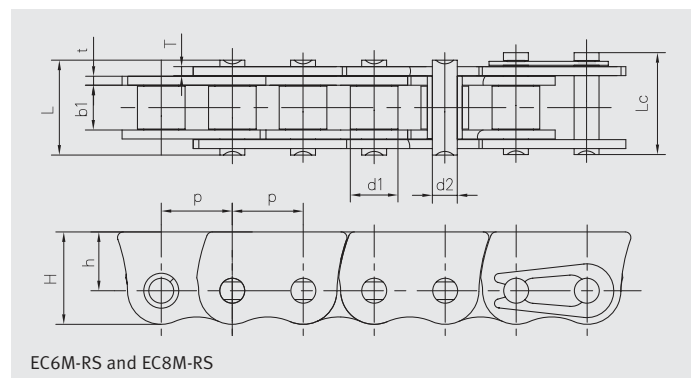
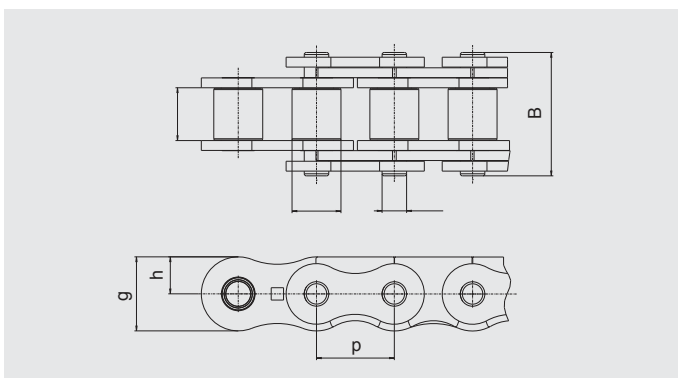

## JWIS® Plate Chains

For really tight bends

### PROBLEM/INITIAL SITUATION

Ensuring the reliable, smooth conveying and storage of workpieces and workpiece carriers on narrow serpentine tracks.

### OUR SOLUTION

JWIS brand plate chains with special plates pressed directly onto the chain pins guarantee an absolutely flat, step-free transport track in the tightest of spaces.



### HIGHLIGHTS

- The iwis plate chain program includes roller chains according to standard ISO 606, ISO 1275 as well as works standard
- Guarantees an absolutely flat, step-free transport track
- Low noise emission
- Wide variety of different plate shapes allows individualised conveyor system design
- Various alternative plate materials available

- Effective protection of functional areas of the chain
- Intermeshing design of plates provides a continuous flat surface for workpiece transport
- Special plate shape allows the construction of very tight be
- Long conveying distances possible in very small spaces
- No risk of injury
- DIN sprockets may be used
- CAD data of all plate chain types available

### AREAS OF APPLICATION

- Conveyor technology
- Beverage industry
- Automotive industry
- General engineering
- Packaging and food industry
- Medical technology and pharmaceutical industry
- Machine-to-machine linking and automation
- Storage and buffer systems
- Tool transport
- Under-floor conveyors

### SOME EXAMPLES OF DIFFERENT PLATE CHAIN VERSIONS

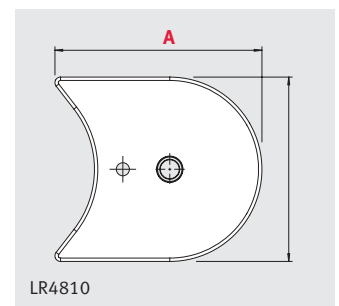
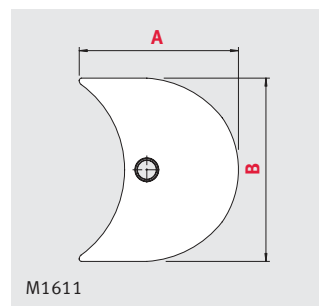
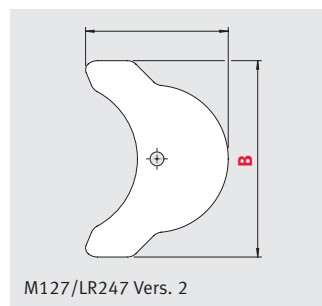
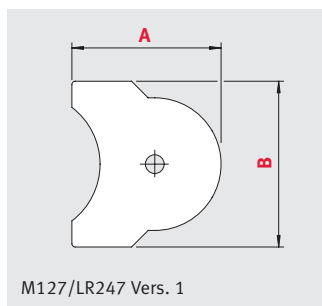

### HIGHLIGHTS

- 1 Wide variety of different plate shapes allows individualised conveyor system design
- 2 Various alternative plate materials available

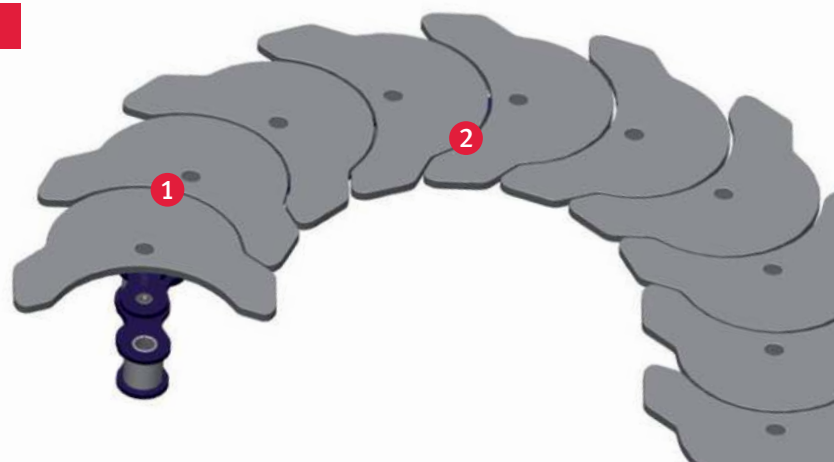

**KNOW-HOW/ENGINEERING**

If required, iwis will design customer-specific solutions for conveyor systems. Our design engineers will provide support with the configuration, calculation and construction of new conveyors.

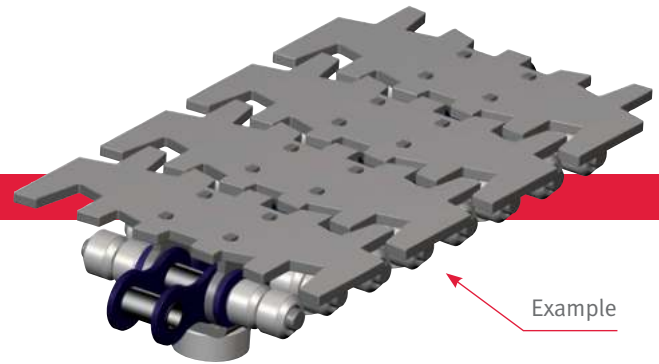

Contact us for more details!

ISO	iwis reference	P (mm)	s (mm)	A (mm)	B (mm)	Min. radius R (mm)	Min. no. ofteeth per sprocket	a (mm)	a1 (mm)	m (mm)	Basic chain
12 B-1	M127 Vers. 1	19.05	3.5	45	50	64	21	24.8	26.25	23.3	standard
12 B-1	M127 Vers. 2	19.05	3.5	59.25	80	152	50	24.8	26.25	23.3	standard
16 B-1	M1611	25.4	3.5	69.5	80	90	22	37.4	39.9	35.4	standard
212 B-1	LR247 Vers. 1	38.1	3.5	45	50	62	10	-	26.35	23.05	cranked
212 B-1	LR247 Vers. 2	38.1	3.5	59.25	80	152	25	-	26.35	23.21	cranked
-	LR4810	76.2	3	92.6	82.5	147	12	34.0	35.9	31.12	standard

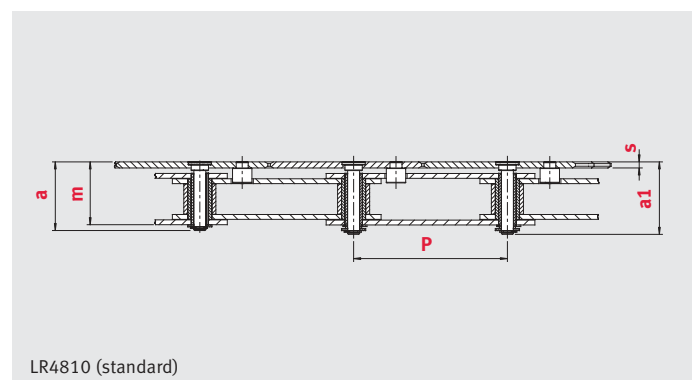
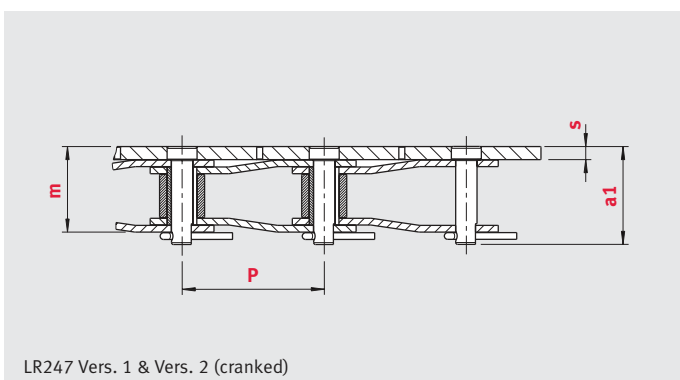
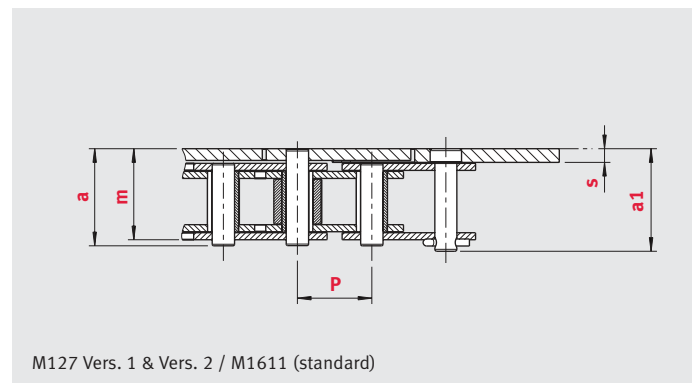
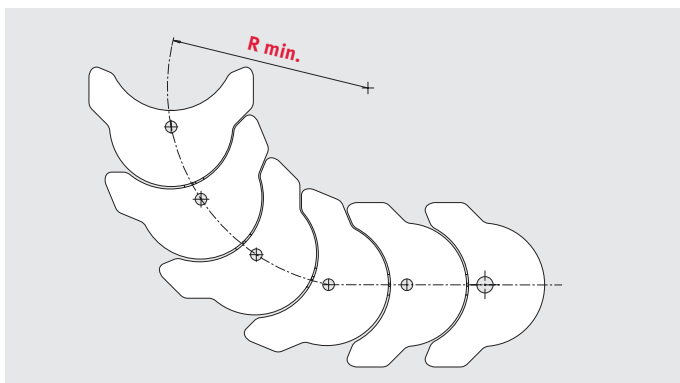

## iwis® Transfer Chains according to ISO 606

Conveying, transporting, stop-start conveying of single parts, pallets...

### PROBLEM/INITIAL SITUATION

Open conveyor systems are susceptible to contamination by foreign bodies or small parts, which can cause belt malfunction or damage the goods.

### OUR SOLUTION

Fully enclosed transfer chains (= TF) with wear-resistant, rugged snap-on plastic attachments prevent malfunctions caused by foreign bodies etc.  
**Exclusive to iwis.**



### HIGHLIGHTS

- All-round protection of functional components of the chain: attachments enclose the chain on three sides, even in the vicinity of sprockets
- Variety of base chains available e.g. **MEGALife**, nickel-plated or corrosion-proof
- Gentle handling of delicate goods
- Close-fitting covers prevent the risk of injuries and malfunctions
- Outside of the chain is absolutely clean, so there is no accumulation of dust
- Drive chain always remains clean, even under adverse operating conditions
- Suitable for horizontal and vertical installation
- No lifting of the load in the vicinity of the sprockets

### TECHNICAL CHARACTERISTICS

#### Chain configuration

Depending on conveyor situation, friction coefficients of 0.1 to 0.3 are assumed for determination of the required chain tensile force. The friction coefficients refer to the contact between chain and chain guide. Base chain calculation is performed according to the examples set out in the iwis Chain Engineering Handbook or via the iwis chain calculation programme available on our website.

#### Important: TF roller chains are not riveted!

You can rely on iwis for help and support in case you have enquiries about details of chain design or CAD data. Please contact us if you need help.

### AREAS OF APPLICATION

- General mechanical engineering
  - Conveyor and warehouse technology
  - Packaging and food industry
  - Electronic components and PCB production
  - Electrical goods and household appliances
  - Medical devices and pharmaceuticals
  - Wood, glass and pottery processing
  - Chemicals and process engineering
  - Printing and paper industry.
- ... and in all other applications that call for gentle handling.

The chain is particularly suitable for machine-processed parts – even items with sensitive surfaces.

DIN/ISO No.	iwis designation	Standard chain	Pitch p (mm)	Mean breaking load iwis $F_B$ (N)	Innerwidth inner link b1 (mm)	Roller $\phi$ d1 (mm)	Width B (mm)	Attachment					
								Height H (mm)	Height above centre of pin h (mm)	Max. load per attachment F (N)	Max. permitted surface pressure vertical (N/mm <sup>2</sup> )	Chain weight (kg/m)	Max. pull-off force acc. to iwis test (N)
08 B-1	L85 TF	L85 SL	12.7	22,000	7.75	8.51	19.85	15.5	8.1	137	0.45	0.84	200
10 B-1	M106 TF	M106 SL	15.875	27,000	9.65	10.16	25.0	17.6	9.7	195	0.45	1.18	300
12 B-1	M127 TF	M127 SL	19.05	32,700	11.75	12.07	29.8	19.9	11.3	265	0.45	1.59	620

\*The suffix SL (Super Longlife) denotes base chains with especially wear-resistant pins

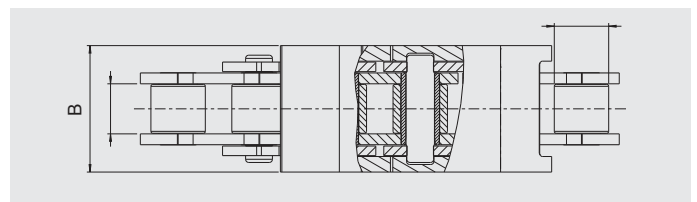
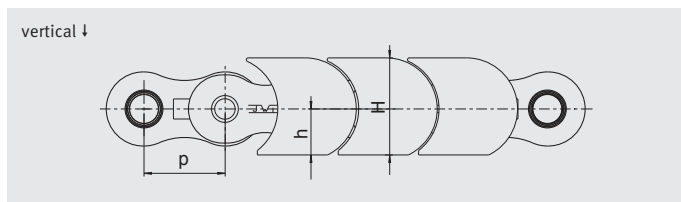

## ATTACHMENT CHARACTERISTICS

iwis offers three attachment versions. The basic assumption for all temperature specifications is a max. surface pressure of 0.45 MPa; significantly higher temperature ranges are possible if surface pressure is lower. Please contact iwis in advance for advice.

### 1. Standard applications

Colour:	white
Water absorption ASTM D570:	0.22%
Rockwell hardness M-scale ASTM D785:	80
Surface resistance ASTM D257:	> 1.0E + 15Ω
Max. temperature short-term:	140 °C
Max. temperature constant:	100 °C
Min. temperature:	-50 °C

### 2. Heat-resistant applications

Colour:	black
Water absorption ISO 62 in normal climate:	0.25%
Ball indentation hardness ISO 2039-1:	130 MPa
Surface resistance IEC 60093:	> 1.0E + 15Ω
Max. temperature short-term:	150 °C
Max. temperature constant:	140 °C
Min. temperature:	-50 °C

Different material configurations are possible for special applications e.g. with gradients, accumulation or aggressive media. In these cases, please contact iwis for an individual advisory consultation.

### 3. Antistatic applications

Colour:	light grey
Water absorption ISO 62 in normal climate:	9%
Surface resistance IEC 60093:	6.8E + 12Ω
Max. temperature short-term:	130 °C
Max. temperature constant:	90 °C
Min. temperature:	-40 °C



## JWIS® Transfer Chains according to ISO 606

Conveying, transporting, stop-start conveying of single parts, pallets...

### CHAIN GUIDES

For iwis transfer chains installed horizontally, we recommend T-shaped chain guides to support the chain rollers. T-shaped chain guides are not required for vertical chain installation.

iwis designation	$B_1$ (mm)	$b$ (mm)	$h$ (mm)	$H_1$ (mm)
08B-1	20	7.5	3.1	15.6
10B-1	25	9.5	3.5	17.7
12B-1	30	11.3	3.9	20.1

### CONNECTING LINK

The chain ends are connected by a two-pin outer link block ① and a push-fit side plate ② pressed onto the pins. By bending the chain appropriately, the two attachments ③ can be clipped on over the pin. A locking spring is not required. The two relevant attachments are coloured black for easy location of the connecting link.



Connecting link: Same dimensions as chain

Vertical

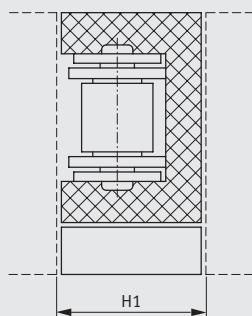

Horizontal

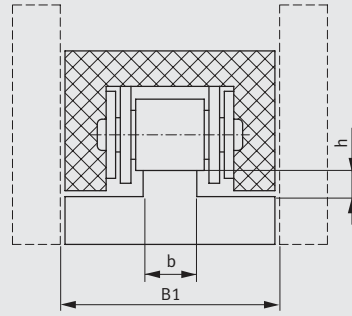

### CORROSION RESISTANCE

Corrosion-proof CR chains, nickel-plated chains or low-maintenance **MEGALife chains** with maximum service life can also be used as base chains for transfer chains. For more information on these chains, please refer to the catalogue "JWIS Precision chain systems for drive and conveyor purposes".

### LUBRICATION

Selecting the right lubricant and the appropriate lubrication method guarantees minimisation of chain wear, adequate corrosion protection and optimum damping performance. Depending on the required application, the base chain can be treated with one of the iwis initial lubricants. For an overview of lubricants, please refer to the catalogue "JWIS Precision chain systems for drive and conveyor purposes".

### SPROCKETS

Standard sprockets compliant with DIN 8187 can be used for TF chains. In the case of sprockets where  $z > 18$ , the TF chain is also completely enclosed in the vicinity of the sprockets and the drive chain is protected against the ingress of foreign bodies.

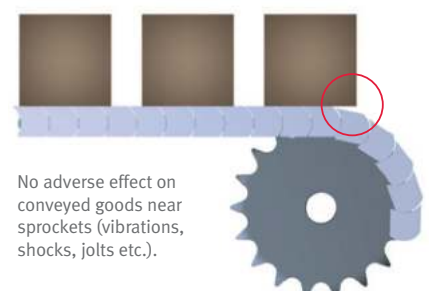

No adverse effect on conveyed goods near sprockets (vibrations, shocks, jolts etc.).



## **iwis® Hollow Pin Chain**

Simple fixing of attachments and transverse struts

ISO	iwis reference	ANSI Ref. no.	Pitch p (")	Pitch p (mm)	g (mm)	B (mm)	D (mm)	Tensile strength $F_a$ (N)	Weight (kg/m)
12 A-1	M 128 HB	60-1	3/4	19.05	18.0	25.5	6	36,500 <sup>1)</sup>	1.23

<sup>1)</sup> Breaking strength without pins inserted 34,500 N

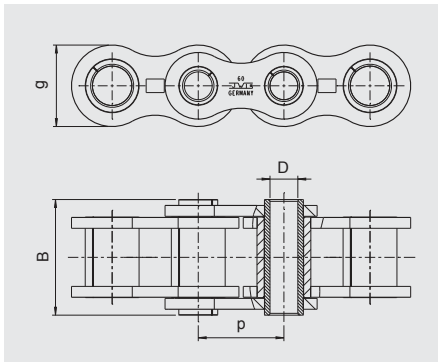

Special bush chain in accordance with roller chain 3/4 x 1/2 inch to ISO 606. Hollow pins can be arranged at any desired interval.



## iwis® Pallet Transporting Chains

### HIGHLIGHTS

- Material to be transported can be positioned throughout because of the straight side plates
- Roller chains with straight side plates for transporting a wide range of material
- Also available in MEGAlife version

iwis reference	Pitch $p$ (mm)	$g$ (mm)	Ave. tensile strength $F_b$ (N)	Weight $q$ (kg/m)
Single strand chain M 128 AG	19.05	18.0	42,000	1.75
Double strand chain D 128 AG	19.05	18.0	84,000	3.50

Dimensions and figures not stated correspond to those for iwis chains M 128 A SL or D 128 A to ISO 606, ANSI Standard.

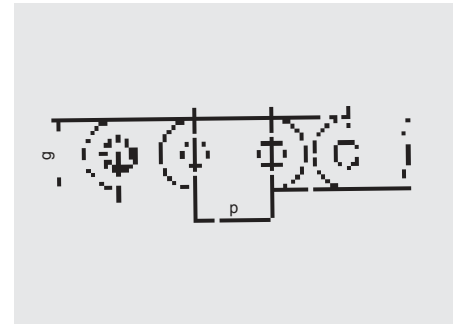

## iwis® Side Bow Chains

Transporting, conveying, pulling on curved shape tracks

### PROBLEM/INITIAL SITUATION

- Transporting and conveying on curved shape tracks
- Chains twisting when the shafts are at an angle to each other
- Change in the position of the material being transported e.g. from the horizontal to the vertical

### OUR SOLUTION

iwis high-performance chains with specially designed chain link.

**Exclusive to iwis.**

### HIGHLIGHTS

- Instead of being in contact with the line, the chain link is in overall contact throughout the curved area.
- Very narrow radii of curvature are possible because of symmetrical, tapered pins
- By using iwis straight and bent side plates suitable for universal use as conveyor chains

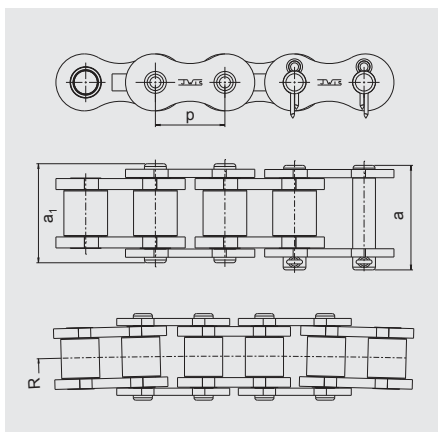

iwis reference	Pitch $p$ (mm)	$a_1$ (mm)	Outer width $a$ (mm)	Min. radius $R$ (mm)	Tensile strength $F_b$ (N)	Continuous (N)	Transient (N)	Weight (kg/m)	Max. permissible chain pull power	Connecting links available
L 85 A-SB	12.7	16.8	17.8	425	10,000	600	1,500	0.65		2, 4, 8
M 106 A-SB	15.875	21.0	22.3	500	18,000	900	2,500	1.00		2, 4, 8
M 128 A-SB	19.05	26.3	27.7	750	26,000	1200	3,700	1.50		2, 4, 8

Dimensions and values not stated here correspond to iwis chains L 85 A, M 106 A and M 128 A SL.

**iwis® Leaf Chains**

iwis reference	Pitch		Length over 100 x pitch (mm)	Plate combination	Arrangement	Min. iwis tensile strength $F_u$ (N)*	Bearing area $f$ (cm <sup>2</sup> )	Weight $q$ (kg/m)	Bearing pin diameter $d_1$ (mm)	$a_1$ (mm)	Overall width $a$ (mm)	End link dimensions									
	$p$ (inch)	$p$ (mm)										$g_2$ (mm)	$g_3$ (mm)	$u_1$ (mm)	$u_2$ (mm)	$u_3$ (mm)	$u_4$ (mm)				
FL 522	-	8.0	800.0	2 x 2		5,000	0.05	0.15	2.31	5.6	-	6.3	1.0	6.2	-	16.0	-	15.0	10.0	-	-
FL 523	-	8.0	800.0	2 x 3		7,000	0.05	0.19	2.31	6.7	-	6.3	1.0	6.2	-	16.0	-	15.0	10.0	-	-
FL 623 <sup>1)</sup>	3/8	9.525	945.0	2 x 3		10,000	0.08	0.32	3.31	8.3	-	8.1	1.2	6.2	-	16.0	-	15.0	10.0	-	-
FL 623 b <sup>1)</sup>	3/8	9.525	944.0	2 x 3		20,000	0.20	0.46	3.31	10.9	-	8.2	2.0	6.2	-	-	-	-	-	-	-
FL 823 b	1/2	12.70	1265.0	2 x 3		28,000	0.18	0.65	4.45	12.4	-	10.8	2.0	8.2	-	18.0	-	20.0	11.0	-	-
FL 834 a	1/2	12.70	1268.0	3 x 4		21,000	0.17	0.42	3.68	13.1	-	9.1	1.5	8.2	-	18.0	-	20.0	11.0	-	-
FL 834 b	1/2	12.70	1265.0	3 x 4		42,000	0.27	0.91	4.45	16.5	-	10.8	2.0	8.2	-	18.0	-	20.0	11.0	-	-
FL 845 a	1/2	12.70	1268.0	4 x 5		34,000	0.24	0.67	3.68	16.9	25	9.1	1.6	8.2	12.2	18.0	25.0	20.0	11.0	30.0	15.0
FL 866 bd	1/2	12.70	1263.0	3 x 3 <sup>2)</sup>		62,000	0.40	1.17	4.45	20.6	28	10.8	1.5	8.2	-	18.0	-	20.0	11.0	-	-
FL 1044 bd	5/8	15.875	1587.5	2 x 2 <sup>2)</sup>		57,000	0.37	1.12	5.08	16.8	28	13.7	1.8	10.4	16.2	20.0	35.0	25.0	12.0	45.0	21.0
FL 1066 bd	5/8	15.875	1587.5	3 x 3 <sup>2)</sup>		86,000	0.55	1.68	5.08	24.0	35	13.7	1.8	10.4	16.2	20.0	35.0	25.0	12.0	45.0	21.0
FL 1266 bd	3/4	19.05	1898.0	3 x 3 <sup>2)</sup>		115,000	0.76	2.18	5.72	30.0	40	14.9	2.2	10.4	16.2	20.0	35.0	25.0	12.0	45.0	21.0
FL 1644 d	1	25.40	2530.5	2 x 2 <sup>2)</sup>		157,000	1.00	2.92	8.28	28.0	40	20.8	3.0	12.2	18.2	25.0	40.0	30.0	15.0	50.0	24.0
FL 1666 d	1	25.40	2530.5	3 x 3 <sup>2)</sup>		231,000	1.50	4.35	8.28	41.0	50	20.8	3.0	12.2	18.2	25.0	40.0	30.0	15.0	50.0	24.0

<sup>1)</sup> Straight side plates <sup>2)</sup> double \*iwis standard

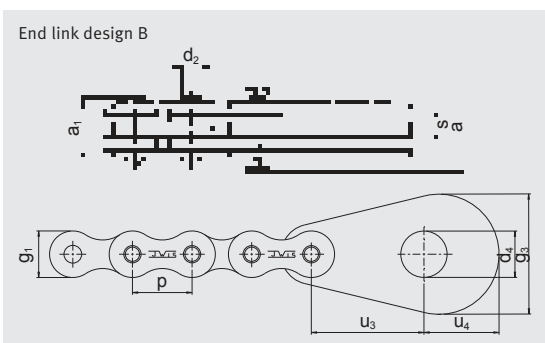
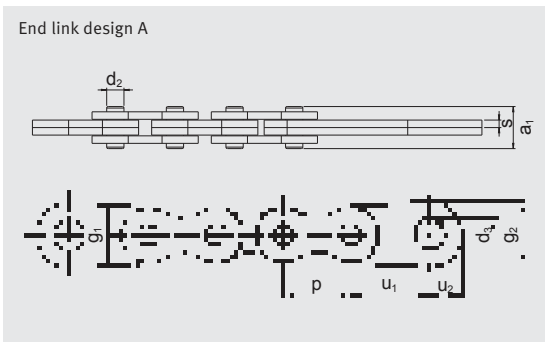

**iwis Leaf Chains**

are manufactured from precision iwis roller chain parts according to ISO 606. Therefore the actual pitch deviates from the nominal pitch. For length calculations use the length over 100 x pitch, not the nominal pitch.

Special versions and combinations with roller chains are available on request.

Dimensioning should be carried out with at least a 10-fold safety margin, depending on chain exposure to low- or high-impact shocks and subject to any regulations imposed by external authorities.

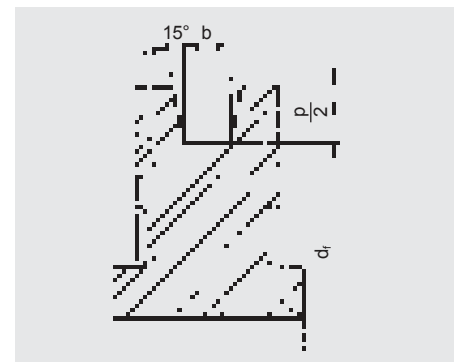

Example for the design of a deflection roller

Inner roller width:  
 $b = a_1 \cdot 1.15$   
 Minimum base diameter:  
 $d_{fmin} = p \cdot 5$

Where possible, fit large diameters.



# Chain Condition Monitoring “Smart”

The **CCM-S**, the latest chain monitoring innovation from iwis, is now equipped with additional sensors and interfaces, measures the wear elongation of chains during use and, in this way, helps maintenance staff recognise in good time when the chain has to be replaced due to wear elongation.

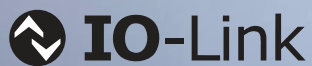

- ✓ Digitalisation interface
- ✓ Ready-to-install plug-and-play principle
- ✓ Optimised design



# CCM-S Chain Condition Monitoring "Smart" (CCM-S)

The chain elongation monitoring system

## INTELLIGENT CHAIN MONITORING

- Maintenance staff can (re)act in time!
- No long downtimes of production lines and machines
- Optimized maintenance and service intervals through digital condition monitoring
- Avoidance of financial losses due to unplanned production downtimes
- Monitoring of precise chain applications
- System based on the "plug-and-play" principle – no calibration necessary
- Wear- and impact-resistant 1 sliding shoe
- Stable, leakproof 2 plastic housing (Protection class: IP67)

- ✓ Digitalisation interface
- ✓ Ready-to-install plug-and-play principle
- ✓ Optimised design



### DATA TRANSFER

Globally standardised, field bus-independent IO-Link technology as communication standard.



### SLE FUNCTION

Sections of chain segments can be **measured individually** and then evaluated for deviations from the average elongation. Connectors are sold separately.



### ADD-ON SENSORS

Chain temperature, along with shocks on the CCM-S's sliding shoe, is monitored thanks to two additional sensors.



### PRESENTATION

**Monitoring data** can be displayed locally on the computer via the a free of charge monitoring software provided by iwis.



### SPEED

Different speed ranges and changes of load direction are not a problem for the CCM-S.



### CHAIN SIZES

The CCM-S can be used for **simplex** as well as for **duplex and triplex chains** because only one chain strand is detected at a time.



### CONTACT-FREE

Precise monitoring takes place **contactless** and **without direct intervention** in the the chain drive.



### INTEGRATION

The CCM-S can be integrated **quickly and easily** in numerous chain applications – including as a retrofit without the need for special tools.

## OPERATING CONDITIONS

- Normal industrial environmental conditions  
(For particularly heavy-duty or highly abrasive applications, please contact our support)
- Operating temperature range: 0 °C to 70 °C (32 °F to 160 °F)
- Chains with attachments or extended pins are basically no problem – as long as there occurs no direct contact with the CCM-S.
- Protection class: IP67
- Insensitive to non-magnetic contamination
- We recommend the installation of the CCM-S system in the tight strand, under certain circumstances is the installation in the slack strand also possible.
- USB connection to PC interface (USB connector 2.0 Type A)
- External power supply as per IO-Link specification: 18-30V

## CCM-S ALL-IN-ONE SOLUTION

### Scope of supply consisting of:

- CCM-S module
- Mounting strips
- IODD file [\[DOWNLOAD\]](#)
- PC software [\[DOWNLOAD\]](#)
- Installation and Operating Instructions [\[DOWNLOAD\]](#)

### Optionally available as accessories:

- IO link cable in various lengths: 5 m (Art. 40012346), 10 m (Art. 40012347), 15 m (Art. 40012348) and 20 m (Art. 40013418)
- USB cable (Art. 40012712)
- 3D data exists and is available on request
- Information on electrical and mechanical connections can be found in the Installation and Operating Instructions [\[DOWNLOAD\]](#).

## RANGE

Article no.	Designation	Article no.	Designation
40011816	CCM-S-08B IWIS	40011822	CCM-S-40 IWIS
40011817	CCM-S-10B IWIS	40011824	CCM-S-50 IWIS
40011818	CCM-S-12B IWIS	40011825	CCM-S-60 IWIS
40011819	CCM-S-16B IWIS	40011826	CCM-S-80 IWIS
40011821	CCM-S-20B IWIS	40011827	CCM-S-100 IWIS
40011828	CCM-S-24B IWIS	40011831	CCM-S-120 IWIS
40011829	CCM-S-28B IWIS	40011855	CCM-S-140 IWIS
40011830	CCM-S-32B IWIS	40011856	CCM-S-160 IWIS

**NOTE** The CCM-S system is only used to provide information. It is expressly stated that the system does not protect against chain drive failures and machine stoppages. The CCM-S system also does not indicate the probability of future chain elongations.

The customer is aware that the CCM-S system is preset to a chain elongation value of 3% as reference value. iwis has preset this reference value without reference to concrete applications. The customer can define the reference value independently and verify on his own responsibility whether the reference value is uncritical in the application or if it might lead to critical situations or consequences of damage due to inadmissible chain elongation.

Each customer can change and reset the value suitable for its application via the software supplied or via IO-Link.



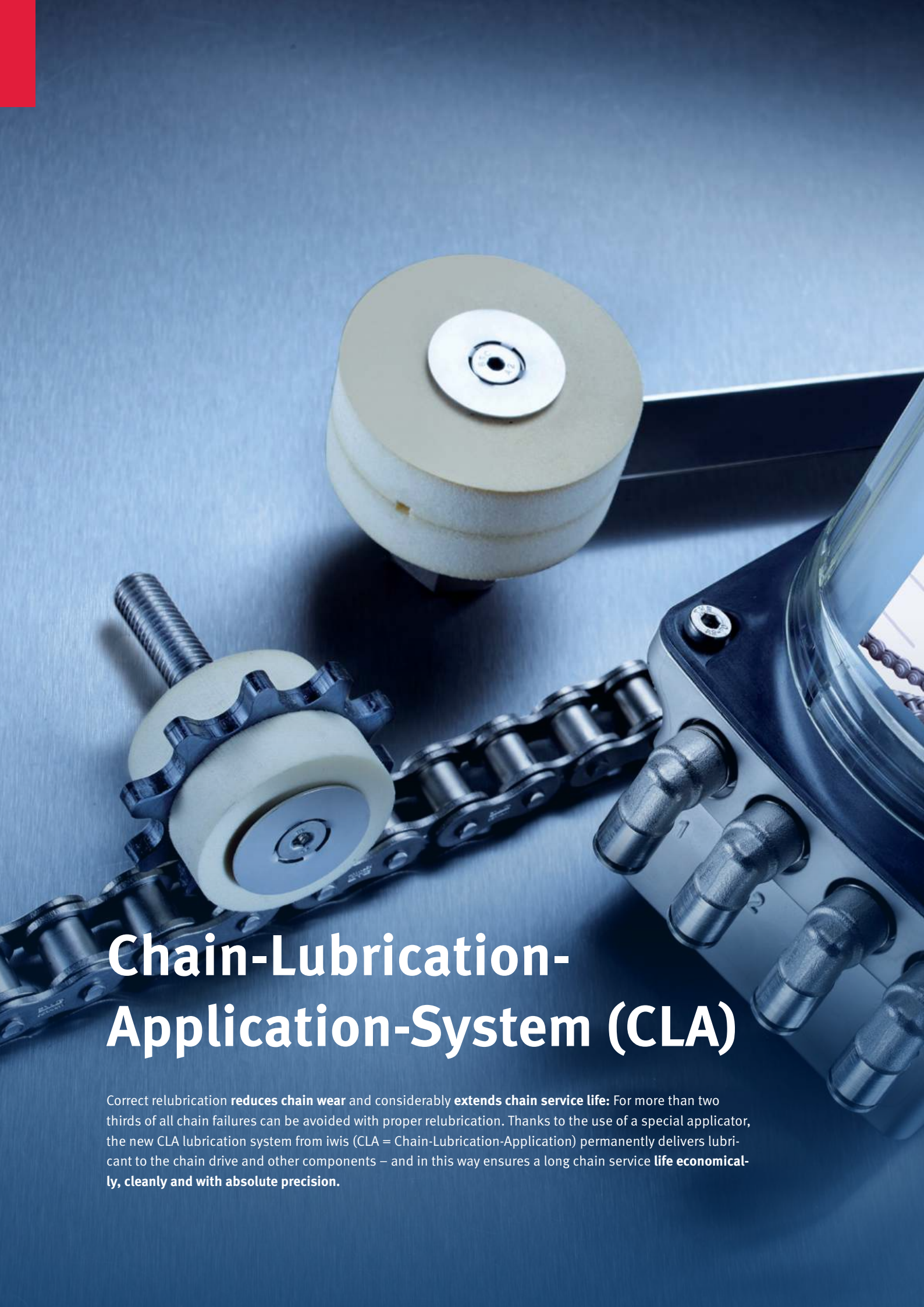

# Chain-Lubrication- Application-System (CLA)

Correct relubrication **reduces chain wear** and considerably **extends chain service life**: For more than two thirds of all chain failures can be avoided with proper relubrication. Thanks to the use of a special applicator, the new CLA lubrication system from iwis (CLA = Chain-Lubrication-Application) permanently delivers lubricant to the chain drive and other components – and in this way ensures a long chain service life **economically, cleanly and with absolute precision**.





80%

**iwis**

antriebssysteme  
wir bewegen die welt

Tel. +49 89 76909-1500  
sales@iwis.com

60%

40%

20%

## Chain-Lubrication-Application (CLA)

The most efficient minimum quantity lubrication system



### FOR A LONG CHAIN LIFE

iwis's new, fully automatic CLA lubrication system for chain drives acts as a highly efficient **minimum quantity lubrication system**. The applicator, which is made from an extremely **resistant material**, acts as a reservoir via which small quantities of lubricant are continuously delivered to the chain at the precise locations where it is actually needed. This prevents the operating chain from sometimes not being supplied with enough lubricant and also prevents unnecessarily large volumes of oil from being dispensed onto the chain and its environment.

The applicators are available in standard dimensions as well as in custom variants.

### HIGHLIGHTS CLA

- Clean, precise minimum quantity lubrication
- Resilient, long-life applicators
- Lubricant is dosed to the applicators at regular intervals. Here, it is buffered and constantly applied to the chain in small quantities
- Economical dosing saves valuable lubricant and protects the environment
- High-performance lubricants for long-lasting lubrication and low consumption
- Simple to install and take into operation
- Can be retrofitted to existing systems without difficulty

### HIGHLIGHTS PUMP

- Compact and powerful with max. 70 bar pump pressure
- Capacity of 400 ml lubricant oil
- Simple and fast to refill with oil
- Error messages issued when lubrication is interrupted: Filling level empty, hydraulic overload due to blocked hoses etc. and over- or undervoltage in the unit
- Remote status monitoring possible

### DEVICE

Dimensions (W x H x D)	111 x 198.5 x 108 mm
Weight (empty)	Approx. 1450 g
Fitting	2x holes for M6 screws
Installation orientation	Vertical
Operating temperature	-15 °C to +60 °C
Protection class	IP54

### HYDRAULIC ELEMENTS

Lubricant volume	Real: 500 ml, software: 400 ml*
Lubricant	Oil, 68 cSt up to 2500 cSt
Max. delivery pressure	70 bar
Delivery volume	0.15 cm <sup>3</sup> per stroke

\* The implemented software uses 400 ml as a basis for calculation as the unit is generally not completely filled.  
Note: No M12x4 cable is supplied as standard

### ELECTRIC ELEMENTS

Operating voltage	24 V
Connector	M12 x 1, 4-pole
Power consumption	At 24 V DC I <sub>max</sub> = 350 mA
Filling level monitoring	Integrated, reed switch
Pressure monitoring	Integrated, electronic
Error message	LCD (time-controlled variant only), PLC

### SAFE OPERATION

- Hoses are not constantly pressurized, so no risk of injury from damaged hoses
- Lubricant empty: Pump reports low oil level
- Overload: Excessive back pressure is detected, for instance if a hose is kinked
- Status messages on operating the pump are displayed directly on the pump (TC version) or reported to the PLC (PC version).

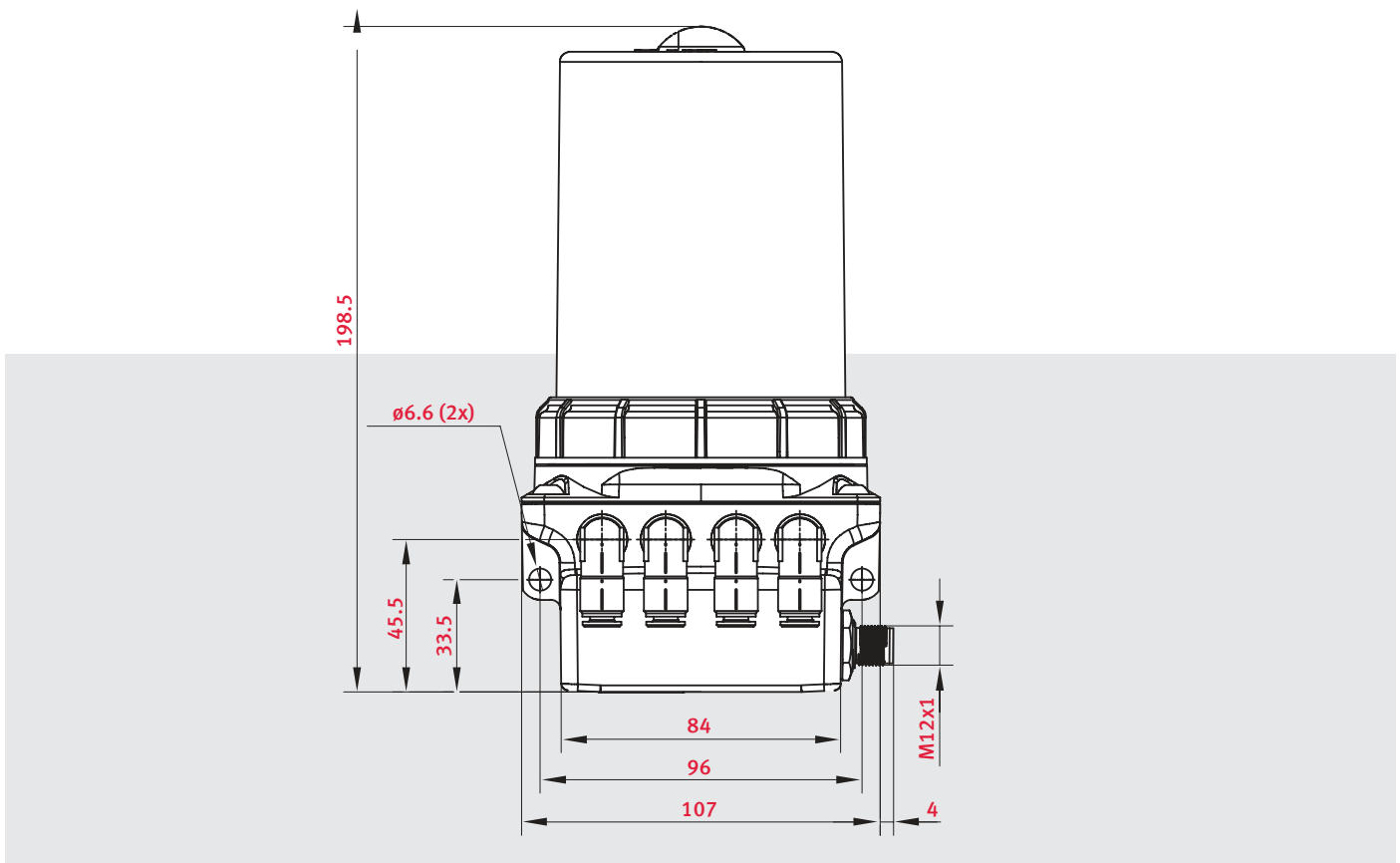

## The following models of the iwis CLA lubrication pumps are available:

	Pulse-controlled via machine's PLC (PC)					Time-controlled (TC standalone)
<b>CLA lubrication pump</b>	1A 1PK 400 ml	2A 1PK 400 ml	2A 2PK 400 ml	3A 2PK 400 ml	4A 2PK 400 ml	2A 1PK 400 ml
<b>Pump outlets</b>	1	2	2	3	4	2
<b>Max. lubrication points with splitter</b>	4	8	8	12	16	8
<b>Different lubrication volumes</b>	1	1	2	2	2	1
<b>Item number</b>	40014911	40014912	40014914	40014915	40014916	40014917

Whereas the pulse-controlled variant of the CLA lubrication pump is controlled by different signal lengths from the machine's PLC, the time-controlled variant allows you to set two different modes using a display on the unit itself: -Et- mode defines the emptying time of the 400 ml within the set time period (e.g. 6 months). In this case, the pauses between the pump strokes are calculated automatically and distributed evenly over the time period. Alternatively, -h mode- can be used to set how often the pump is to deliver lubricant within a given period. For instance, three pump strokes every two hours. One pump stroke always corresponds to 0.15 cm<sup>3</sup> of lubricant, allowing dosing to be tailored to the current application. For further details, refer to the CLA Operating Instructions.

Further information can be found in our product flyer and comprehensive operating instructions at: [www.iwis.com/downloads](http://www.iwis.com/downloads)



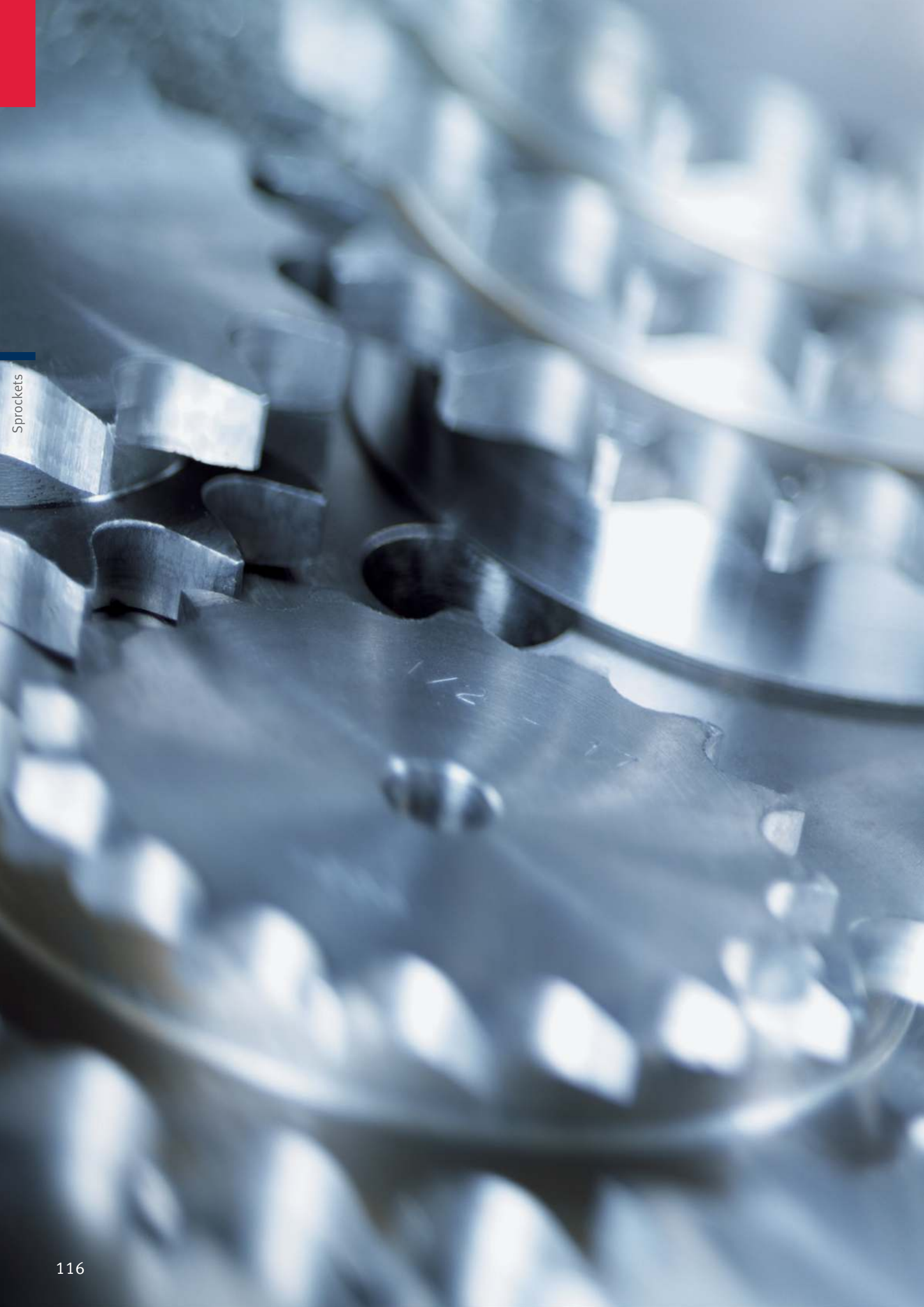

# JWIS<sup>®</sup> Sprockets

The form of the sprockets is determined by the following factors: type of chain, the number of teeth, the torque to be transmitted and the application. A distinction is drawn between sprockets and chain plate wheels for roller chains according to Norm (e.g. ISO 606) and special versions. Sprockets with hub allow the transmission of a higher torque, whereas plate wheels may be used only for the transmission of small torques. For a detailed instruction regarding design and construction of sprockets and plate wheels, please refer to our iwis chain engineering hand book.



## **iwis**® Sprockets and Plate Wheels

according to ISO 606

ISO / Simplex roller chain / Duplex roller chain / Triplex roller chain

### AVAILABLE SPROCKETS AND PLATE WHEELS

ISO	Simplex roller chain	Duplex roller chain	Triplex roller chain
04	•	-	-
05 B	•	•	-
06 B	•	•	•
08 B	•	•	•
10 B	•	•	•
12 B	•	•	•
16 B	•	•	•
20 B	•	•	•
24 B	•	•	•
28 B	•	•	•
32 B	•	•	•

The iwis sprocket and plate wheel program will be supplied from our sister company iwis antriebssysteme GmbH in Wilnsdorf.

For more detailed information about our complete sprocket program, please take note of the catalogue "Sprockets and drive components".



### FURTHER AVAILABLE PRODUCTS

- Taper bush for sprockets
- Chain tensioning wheel complete with ball bearing - ready for installing
- Sprockets for taper bush
- Sliding hub range, series DA
- Sliding hub range, series FT
- ELITE sliding clutches, series FT
- Shaft coupling by chain coupling

### ON REQUEST WE MANUFACTURE AND DELIVER

- Production of **keyways** in accordance with DIN 6885/1 in widths 3 P9/JS9 – 25 P9/JS9, various special sizes available on request
- Conventional **inner processing** of sprockets and turned parts with a max. outer diameter up to 620 mm and a turned length up to 500 mm
- Press-fitting of **ball bearings** in technical drawing-relevant components and production of **chain tensioning wheels** on hydraulic presses fitted with special fixtures
- If requested by the customer, we also offer inductive heat treatment of the gear tooth geometry to prolong material service life
- **Surface treatment** such as zinc plating, black oxidation or nickel plating
- Sprockets with **high tolerance requirements**
- **Drilling of pitch circle holes and threads**
- Production of mechanically processed parts of any geometry up to 350 mm diameter or max. dimensions of 1,050 mm x 560 mm x 460 mm

## Notes

A large rectangular grid consisting of 20 columns and 30 rows of small squares, intended for taking notes.





# **JWTS<sup>®</sup>** Tools

iwis tools facilitate the breaking and riveting of roller chains pursuant to ISO 606 and the iwis norm and are useful for workshop use. The iwis tool product range also includes repairing tools for tube and pin oven chains, accumulation chains and plate chains.



## iwis® Tool Set for workshop use

The fork and anvil extraction kit is suitable for use with chains manufactured to ISO 606. Anvil (A) and fork (A 1) are suitable for breaking chains which have shouldered bearing pins.

To break chains with parallel bearing pins it is necessary to use plate (D 1) together with pin punch (B). The tool kits can also be used to assemble chains.

Fetching up punch (C) and bearing pin riveting punch (E) are used to complete this operation.

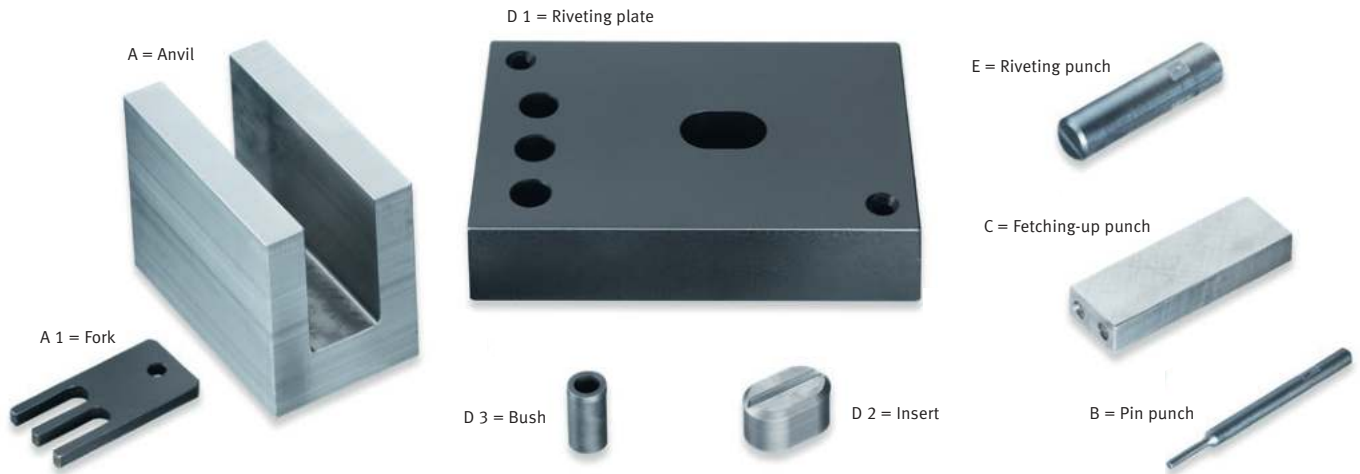

ISO	iwis reference	Pitch (") A	Anvil A	Fork A 1	Pin punch B	Fetching-up punch C	Riveting plate D 1	Insert D 2	Bush D 3	Riveting punch E
<b>Order no.</b>										
05 B	G 52, D 52	8 mm	-	-	5014	40006688	5024	5026	5033	5038
06 B	G 62 1/2, G 67, G 68, EC-6-M	3/8	-	-	5011	40006689	5024	5026	5033	5038
06 B	D 67, EC-6-D	3/8	5001	5007	5011	40006689	5024	5026	5033	5038
-	P 83 V	1/2	-	-	5011	40006692	5024	5026	5033	5038
08 A	S 84 V, L 85 A, D 85 A	1/2	-	-	5011	40006691	5024	5027	5034	5039
08 B	L 85 SL, D 85 SL, EC-8-M, EC-8-D	1/2	5000	5004	5012	40006690	5024	5027	-	5039
10 B	M 106 SL, D 106 SL, EC-10-M	5/8	5000	5005	5013	40006693	5024	5027	-	5039
10 A	M 106 A, D 106 A	5/8	-	-	5013	40006694	5024	5028	5034	5040
12 B	M 127 SL, D 127, EC-12-M, EC-12-D	3/4	5000	5006	5013	40006695	5024	5028	-	5040
12 A	M 128 A SL, D 128 A	3/4	-	-	5016	40006696	5024	5028	5035	5040
16 A	M 1610 A, D 1610 A	1	-	-	5015	40006705	5024	5029	5035	5041
16 B	M 1611, D 1611, EC-16-M, EC-16-D	1	5002	5008	5015	40006697	5024	5029	-	5041
20 B	M 2012, D 2012, EC-20-M, EC-20-D	1 1/4	5003	5009	5015	40006698	5025	5030	-	5042
24 B	M 2416, D 2416, EC-24-M, EC-24-D	1 1/2	-	5010	5017	40006699	5025	5032	5036	5044

## Applications

### Breaking chains and chain assembly

#### BREAKING (PARALLEL BEARING PIN)



The outer link to be broken has to be placed over the holes in the riveting plate (D). The bearing pins are hammered flush with the outer plate and then driven through the chain with pin punch (B) whose diameter must be smaller than that of the bearing pin ①. To assist when breaking large pitch chains it is recommended that the rivet head is initially ground away.

#### BREAKING (SHOULDERED BEARING PIN)



The fork (A 1) is placed through the chain at the outer link which is to be removed. The fork is then supported by the anvil and the bearing pins are driven through the chain using punch (B) ②. Multiple strand chains can also be broken in this way, the fork should then be placed in the top strand of the chain.

#### ASSEMBLY



The procedure used is common to both shouldered and parallel bearing pin chains. The new riveting link connects the two inner links. This connecting link is supported by an insert in riveting plate (D) ③.



A new outer link plate is fitted using fetching-up punch (C) ④. With parallel bearing pin chain it is possible to over fit the outer link plate on the bearing pins. It is necessary to check that the joint remains free and easily moveable after fitting.



The newly fitted outer link then requires the bearing pin ends to be riveted. This is done with riveting punch (E) ⑤.

## JWIS® Chain Breaker

### How to use the iwis multi-station chain breaker

#### CHAIN BREAKER

iwis tools are very handy for the workshop as they make it easy to cut roller chains made to ISO 606 (DIN 8187/8188) and to our works standard in different lengths.

This chain breaker can be clamped in a vice or screwed onto a workbench. Position it at the front edge of the bench to provide enough space for the lever to swing down fully. Surfaces to rest the chain to the left and right will make it easier to handle long chains.

The rotating head holds five sets of ejector tools, each of which is marked with the respective size of chain. If set correctly, both chains with shouldered and chains with straight pins can be broken.

The following chain sizes can be cut in lengths by the JWIS Chain Breaker:

- 06B to 12B
- 08A to 12A

ARTICLE NO. 4500

#### REPLACING THE PRESSURE PINS AND SUPPORT FORKS

##### Pressure pins ①:

Loosen grub screws ② pull pins out upwards. Replace as a complete set.

##### Support forks ③:

Loosen top nut ④ after knocking out safety spring pin. Press out middle bolt ⑤ downwards and remove tool tray ⑥ forward. Take out the two spring pins which secure the support fork. Insert new fork.

Pay attention when reassembling, that the pressure plate ⑦ is correctly positioned with the latch pin at the back of the body casting. Tighten nut ④ back up and secure with pressure pin.

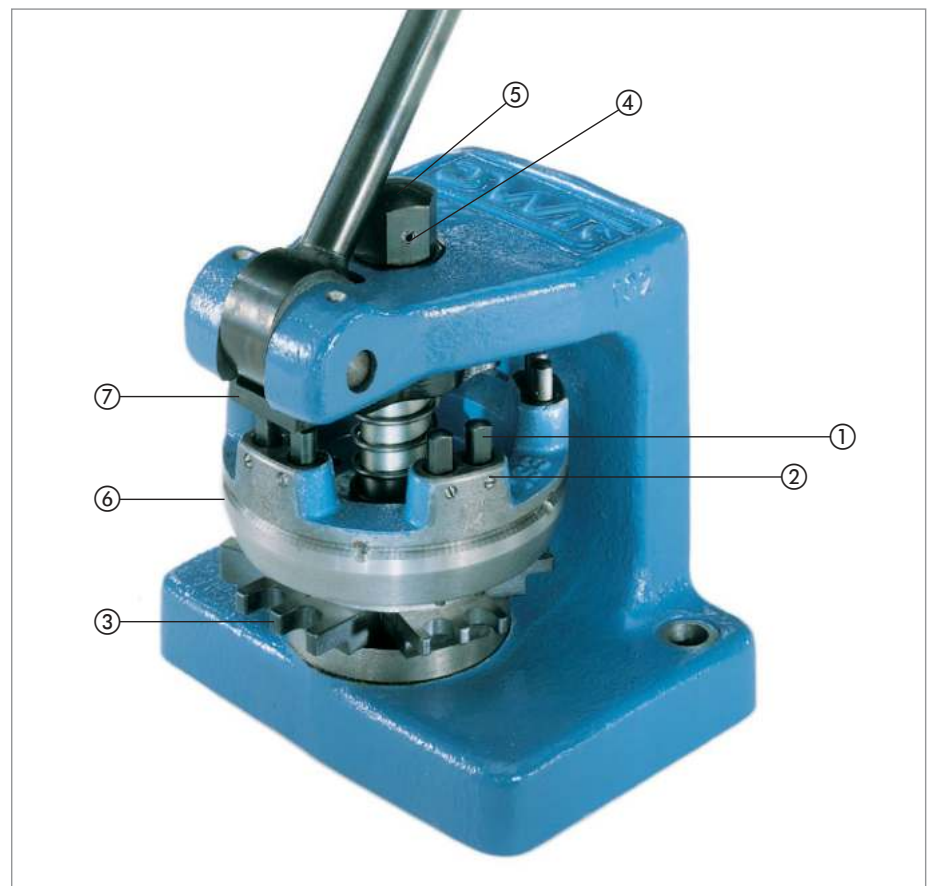

## **iwis**® Chain Breaker

### How to use the iwis multi-station chain breaker

#### A) CHAINS WITH SHOULDERED PINS



Chain link with shouldered pin

For breaking chains with shouldered pins the chain is fitted into the appropriate fork according to pitch, and the complete outer link is pressed out when the lever is pulled. It is important that the chain is fully located in the fork.

ISO	iwis reference	Pitch	Adjustment
06 B - 2	D 67	3/8 x 7/32	3/8
06 B - 3	TR 67	3/8 x 7/32	3/8
08 B - 1	L 85 SL	1/2 x 5/16	1/2
08 B - 2	D 85 SL	1/2 x 5/16	1/2
08 B - 3	TR 85	1/2 x 5/16	1/2
10 B - 1	M 106 SL	5/8 x 3/8	5/8
10 B - 2	D 106 SL	5/8 x 3/8	5/8
10 B - 3	TR 106	5/8 x 3/8	5/8
12 B - 1	M 127 SL	3/4 x 7/16	3/4
12 B - 2	D 127	3/4 x 7/16	3/4
12 B - 3	TR 127	3/4 x 7/16	3/4

#### B) CHAINS WITH PARALLEL PINS



Chains with parallel bearing pins

For breaking chains with parallel pins it is necessary to grind off the rivet heads on one side of the chain. Afterwards the outer link is pressed out as above.

ISO	ANSI type	iwis reference	Pitch	Adjustment
06 B - 1	-	G 67	3/8 x 7/32	3/8
08 A - 1	40-1	L 85 A	1/2 x 5/16	1/2
08 A - 2	40-2	D 85 A	1/2 x 5/16	1/2
08 A - 3	40-3	TR 85 A	1/2 x 5/16	1/2
10 A - 1	50-1	M 106 A	5/8 x 3/8	5/8
10 A - 2	50-2	D 106 A	5/8 x 3/8	5/8
10 A - 3	50-3	TR 106 A	5/8 x 3/8	5/8
12 A - 1	60-1	M 128 A SL	3/4 x 1/2	3/4
12 A - 2	60-2	D 128 A	3/4 x 1/2	3/4
12 A - 3	60-3	TR 128 A	3/4 x 1/2	3/4

If a grinding device is not available the rivets can be knocked out with a punch after the outer sideplate has been pressed off. Here the bushes must be well supported to prevent them coming off the inner plates

when the pressure pins and support forks are being replaced. Although chains can be taken apart without pregrinding the riveted head the danger of damage to the bush bore does exist. This could reduce chain

life. The iwis multi-station chain breaker can also be used to cut conveyor chains with straight or bent attachments plates of corresponding size. It is not suitable for 3/8 x 5/32" chains.

## **iwis**® Repairing Tool for Tube and Pin Oven Chains

### Replacement of conveyor pins

#### SPECIAL TOOL

The above represented iwis tool has been specially developed to repair tube and pin oven chains.

It allows easy replacement of conveyor pins on already installed chains, types L 85 SL, M 106 SL, M 127 SL, M 128 ASL and M 128 A-SB (changeable).

Chain	Pitch	$D_i$	m
L 85 SL	12.7	8.0	22.0
M 106 SL	15.876	8.0	22.0
M 127 SL	19.05	8.0	22.0
M 128 ASL	19.05	10.0	22.0
M 128 A-SB	19.05	10.0	22.0

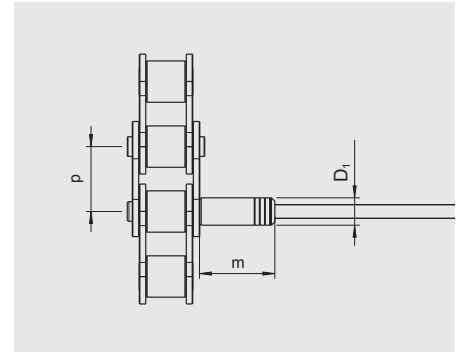

Repairing tool for tube chains and spare parts

Article No.

Mounting plier for adapter 8 mm

40000421

Tool / Insert 8 mm for assembling

40000424

Tool / Insert 8 mm for disassembling

40000425

Mounting plier for adapter 10 mm

40002625

Tool / Insert 10 mm for assembling

40000423

Tool / Insert 10 mm for disassembling

40000422



## How to employ it

### Removal and fastening of pin adapter

#### REMOVE PIN ADAPTER



Insert the adapter into the jaws ① and break it by closing the tool. If necessary, repeat the action after 45° rotation. Once the adapter has been broken, remove the pin.

#### FIXING OF A NEW CONVEYOR PIN



The new adapter is set onto the extended pin. Seize it with the gripping jaws ② and clamp it with the tool. Thus repaired, the chain is operational again.



## **iwis**® Chain Pin Extractor and **iwis**® Chains Pullers

### UNIVERSAL CHAIN PIN EXTRACTOR H



#### ARTICLE NO. 4511

For use with any chain having shouldered bearing pins only.

**Chain ref:**

- 08B-1 / L 85 SL
- 08B-2 / D 85 SL
- 08B-3 / TR 85
- 10B-1 / M 106 SL
- 10B-2 / D 106 SL
- 10B-3 / TR 106
- 12B-1 / M 127 SL
- 12B-2 / D 127
- 12B-3 / TR 127

The chain is clamped between the extractor jaws and the pins are then pressed out one by one by rotating the extractor handle.

### SIMPLE RIVET EXTRACTOR F



#### ARTICLE NO. 4516

For chains with parallel pins.

**Chain ref:**

- P 83 V
- S 84 V

The chain is placed in the tool and the pins are pressed one by one through both outer plates. (Note: This extractor should not be used on chain with shouldered pins).

### CHAIN PULLERS



#### ARTICLE NO. A) 4518 B) 4519

- a) No. 35 for 1/2 to 3/4" pitch chain
- b) No. 80 for 1" to 2" pitch chains

The maximum opening range of the chain puller clamp is 50 mm for type a) and 125 mm for type b).



## **iwis® Tools for Breaking and Riveting of Roller Chains**

### Outline

	no.	Art-No.
Multi-station rivet extractor		4500
<b>Spare parts for iwis multi station rivet extractor</b>		
Pressure plate	7	9806
Spare-part-set fork and 2 punch points for 3/8" incl. spring		11926
Spare-part-set fork and 2 punch points for 1/2" incl. spring		11927
Spare-part-set fork and 2 punch points for 5/8" incl. spring		11928
Spare-part-set fork and 2 punch points for 3/4" incl. spring		11929
<b>Universal rivet extractor</b>		
Universal rivet extractor H for chains of 1/2" to 3/4" pitch		4511
Replacement spindle		4512
Reversible replacement pin		4513
Simple rivet extractors F no.4 for F82V, S84V, L85A		4516
<b>iwis special tools</b>		
Repairing tool for tube and pin oven chains		
Mounting plier for adapter 8 mm		40000421
Tool / Insert 8 mm for assembling		40000424
Tool / Insert 8 mm for disassembling		40000425
Mounting plier for adapter 10 mm		40002625
Tool / Insert 10 mm for assembling		40000423
Tool / Insert 10 mm for disassembling		40000422
Tool for accumulation chains		40000646
Replacement pin		40001734
Chain disassembly tool for plate chains		40003392
<b>Tensioners for mounting procedure</b>		
No. 35 3/8" to 3/4"		4518
No. 80 from 1" on		4519
<b>Additional articles</b>		
Chain gauge		4568
Chain lubricant VP 6 Kombi superplus 400 ml (packaging unit: 12 pcs.)		15701

#### CHAIN DISASSEMBLY TOOLS



#### ARTICLE NO. 40000646

For accumulation chains M 120 SF and M 127 SF with pitch 3/4".

#### CHAIN DISASSEMBLY TOOLS



#### ARTICLE NO. 40003392

For plate chains M 127 with pitch 3/4".

## Jwis® Tools

### Outline

ISO	No.	Art-No.
<b>Anvil A</b>		
08 B, 10 B, 12 B	2	5000
06 B	3	5001
16 B	4	5002
20 B	5	5003
<b>Fork A1</b>		
08 B	2	5004
10 B	3	5005
12 B	4	5006
06 B	6	5007
16 B	8	5008
20 B	9	5009
24 B	10	5010
<b>Pin punch B</b>		
06 B, 08 A	1	5011
08 B	2	5012
10 B	3	5013
05 B	4	5014
20 B, 16 A, 16 B	5	5015
12 A	6	5016
24 B	7	5017
<b>Fetching up punch C</b>		
05 B	1	40006688
06 B	3	40006689
iwis norm 1/2"	4	40006692
08 A	5	40006691
08 B	6	40006690
10 B	7	40006693
10 A	8	40006694
12 B	9	40006695
12 A	10	40006696
16 A	11	40006705
16 B	12	40006697
20 B	13	40006698
24 B	14	40006699

ISO	No.	Art-No.
<b>Riveting plate D1</b>		
05 B-16 B, 08 A-16 A	1	5024
20 B, 24 B	2	5025
<b>Insert D2</b>		
05 B, 06 B	1	5026
08 A, 08 B, 10 B	2	5027
10 A, 12 A, 12 B	3	5028
16 A, 16 B	4	5029
20 B, 24 A	5	5030
20 A	6	5031
24 B	8	5032
<b>Bush D3</b>		
05 B, 06 B	1	5033
08 A, 10 A	2	5034
12 A, 16 A	3	5035
24 B	4	5036
-	5	5037
<b>Riveting punch E</b>		
05 B, 06 B	1	5038
08 A, 08 B, 10 B	2	5039
10 A, 12 A, 12 B	3	5040
16 A, 16 B	4	5041
20 B	5	5042
-	6	5043
24 B	7	5044







# Automatic Tensioners

Automatic chain tensioners compensate the chain elongation in the machines and conveyor systems and that way further the run time of the applied chain. iwis chain tensioners are made from high quality materials. Depending on the application various types are available.

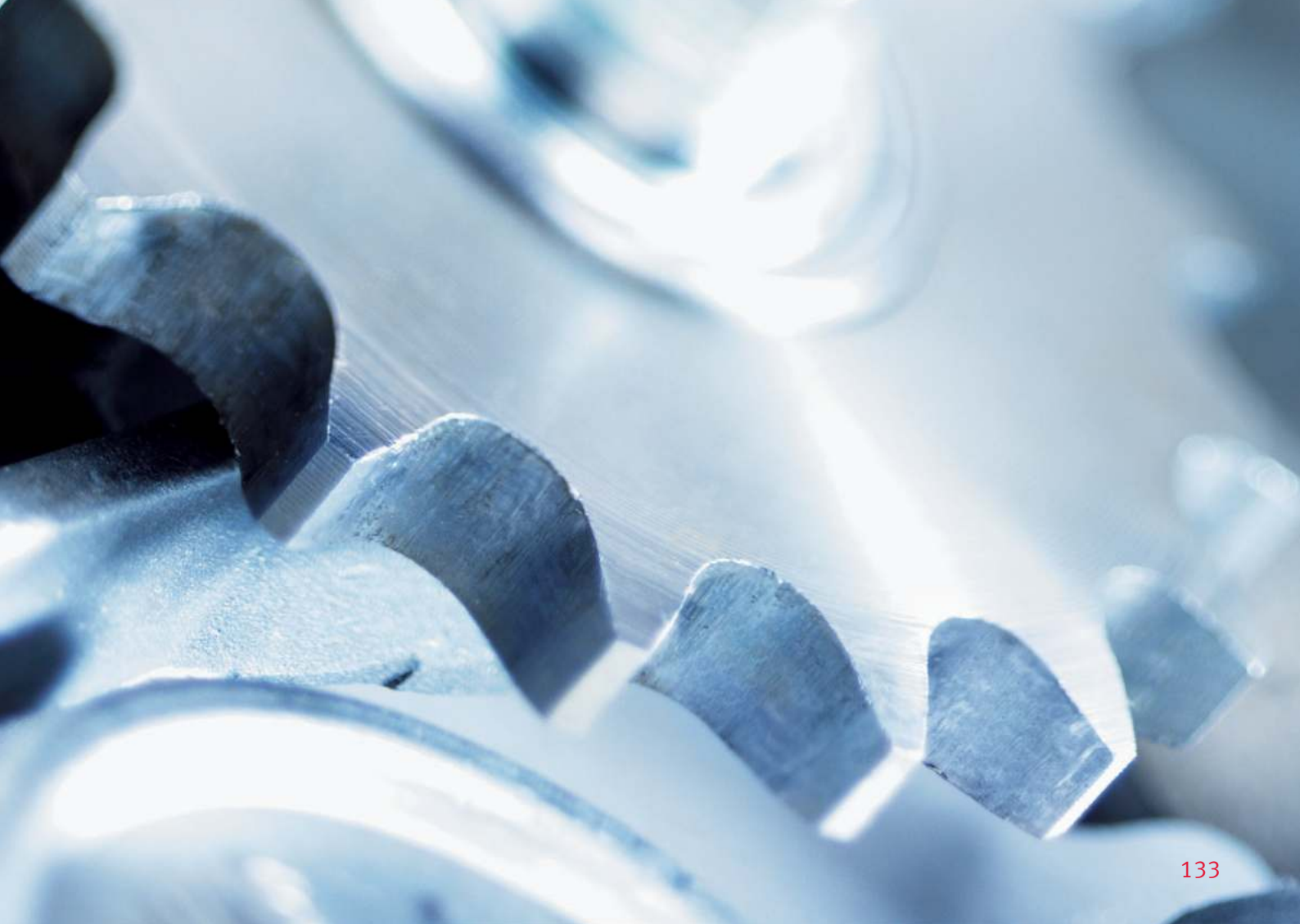

## iwis® RHR Type with sprocket and bearing



	Chain pitch	Newton	A ± 1	B	C	D	E	F	G	H ± 1	L	Q	R	S	T	U	V	Z	
<b>Type RHR</b>																			
RHR 111	3/8" x 7/32"	0÷100	58	6	8	35	80	M6	8.5	51	8	22	5	9.2	19.7	9.7	16.7	21	
RHR 155	3/8" x 7/32"	0÷150	71	8	8.5	45	100	M8	10.5	64	8	30	6	9.2	19.7	9.7	16.7	21	
RHR 155	1/2" x 5/16"	0÷150	71	8	8.5	45	100	M8	10.5	64	8	30	6	9.2	19.7	12.5	19.5	16	
RHR 188	1/2" x 5/16"	0÷300	84	10.5	8.5	58	100	M10	13	78	10	37	8	9.2	19.7	12.5	19.5	16	
RHR 188	5/8" x 3/8"	0÷300	85	10.5	8.5	58	100	M10	13	78	10	37	8	9.2	19.7	15.3	23.3	17	
RHR 277	3/4" x 7/16"	0÷900	114	15	10.5	78	130	M12	17	107	12	53	10	9.2	19.7	17.7	25.7	15	
RHR 277	1" x 17 mm	0÷900	114	15	10.5	78	130	M12	17	107	12	53	10	8.9	19.4	26.4	34.4	12	

### TYPE RHR

- Good damping effect, reducing noise and vibration
- Operating angle > 30° in both directions of rotation
- Simple screw mounting, internally or externally
- Operational temperature -40 °C to +80 °C
- Interchangeable to similar systems
- The sprocket can be mounted on both sides

### EXAMPLE OF ORDER

Tensioner for 1/2" pitch single chain RHR 155 1/2" S. For single chain available from stock. For double chain on request

**S** = single chain **D** = double chain

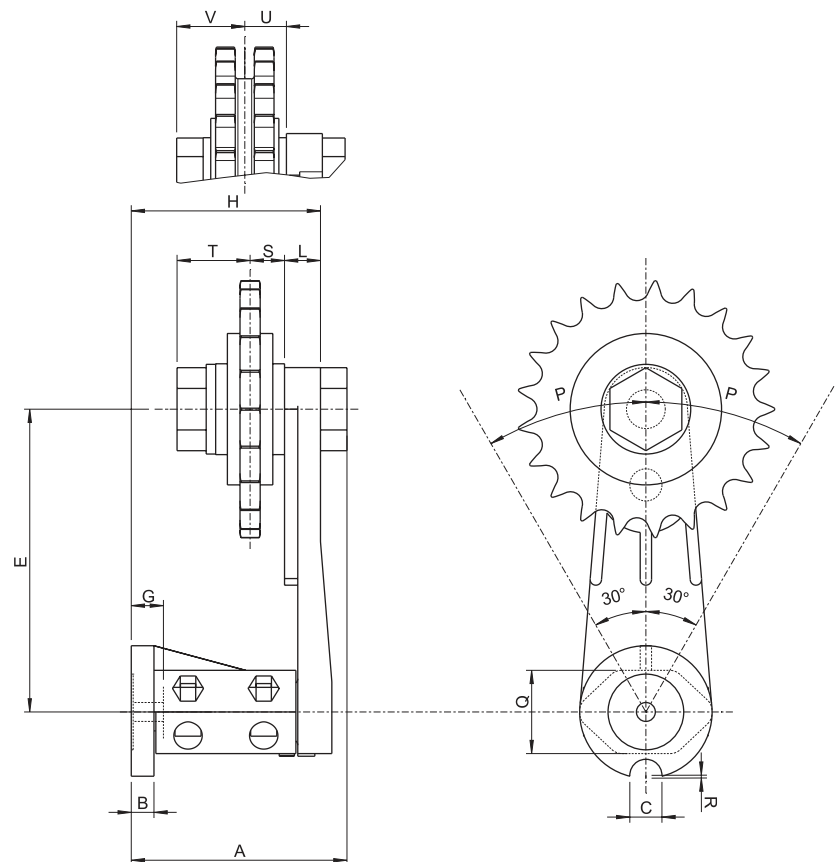

**iwis® RHP Type**  
with low friction coefficient polythene head



	Chain pitch	Newton	A <sub>1</sub> ± 1	B	C	D	E	F	G	H ± 1	I	L	M	N	O	Q	R	U	Y
<b>Type RHP</b>																			
RHP 111	3/8" x 7/32"	0 ÷ 100	57	6	8	35	80	M6	8.5	51	7	8	20	70	20	22	5	22	102
RHP 155	3/8" x 7/32"	0 ÷ 150	70	8	8.5	45	100	M8	10.5	64	7	8	20	70	20	30	6	22	122
RHP 155	1/2" x 5/16"	0 ÷ 150	70	8	8.5	45	100	M8	10.5	64	7	8	20	70	20	30	6	22	122
RHP 188	1/2" x 5/16"	0 ÷ 300	84	10.5	8.5	58	100	M10	13	78	7	10	20	70	22	37	8	29	122
RHP 188	5/8" x 3/8"	0 ÷ 300	85	10.5	8.5	58	100	M10	13	78	8	10	25	90	22	37	8	29	129
RHP 277	3/4" x 7/16"	0 ÷ 900	114	15	10.5	78	130	M12	17	107	8	12	30	90	22	53	10	29	159
RHP 277	1" x 17 mm	0 ÷ 900	114	15	10.5	78	130	M12	17	107	8	12	45	110	25	53	10	35	165

**TYPE RHP**

- Operational temperature -40 °C to +80 °C

**EXAMPLE OF ORDER**

Tensioner for 1/2" pitch single chain RHP 155 1/2" S. For single chain available from stock. For double chain on request.

**S** = single chain **D** = double chain

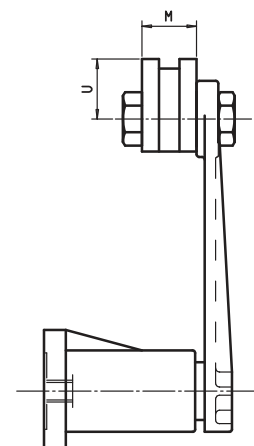
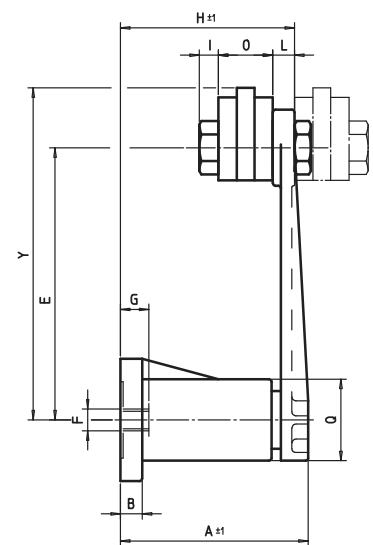
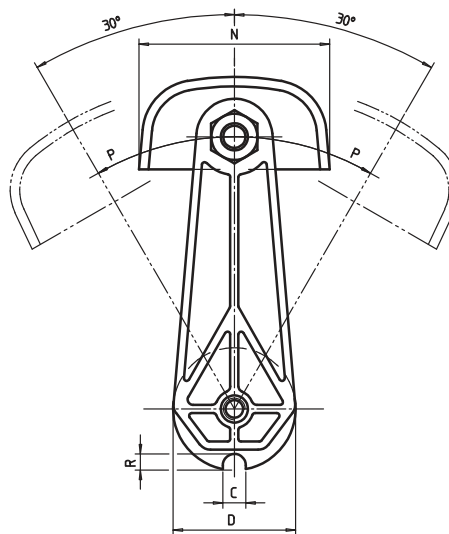

## iwis® TCR Type with sprocket and bearing



Type TCR	Newton		Chain pitch	Z	A	B	C	CH	D	E	F	G	H	I	L	M	N	O	P	β
	min.	max.																		
*TCR-05 – 3/8"	30	80	3/8" x 7/32"	21	5	15	15	24	63	35	23	23	75.5	9.2	119	M10	19.7	-	-	45°
TCR-1 – 3/8"	50	180	3/8" x 7/32"	21	5	15.5	15.5	24	69	36	30	25	86.5	9.2	134	M10	19.7	18	11	45°
TCR-1 – 1/2"	50	180	1/2" x 5/16"	16	5	15.5	15.5	24	69	36	30	25	86.5	9.2	134	M10	19.7	16.5	12.5	45°
TCR-1 – 5/8"	50	180	5/8" x 3/8"	17	5	15.5	15.5	24	69	36	30	25	86.5	9.2	134	M10	19.7	21.8	15.3	45°
TCR-2 – 5/8"	120	500	5/8" x 3/8"	17	7	18	18	27	90	43	34	30	100	9.2	159	M12	19.7	21.8	15.3	30°
TCR-2 – 3/4"	120	500	3/4" x 7/16"	15	7	18	18	27	90	43	34	30	100	9.2	159	M12	19.7	19.4	17.7	30°
TCR-2 – 1"	120	500	1" x 17 mm	12	7	18	18	27	90	43	34	30	100	8.9	159	M12	19.4	23.9	26.4	30°
TCR-2 – 1 1/4"	120	500	1 1/4" x 3/4"	9	7	18	18	27	90	43	34	30	100	11.5	159	M12	19.4	-	-	30°
TCR-2 – 1 1/2"	120	500	1 1/2" x 1"	9	7	18	18	27	90	43	34	30	100	14	159	M12	19.4	-	-	30°

\* Plastic version

### TYPE TC

- Linear force progression
- Operating angle > 45° in both directions of rotation
- Simple screw mounting, internally or externally
- Operational temperature -20 °C to +130 °C
- Resistant against oil and solvents
- Better fastening due to 2 (TCR-1) resp. 3 (TCR-2) grooves
- The sprocket can be mounted on both sides

### EXAMPLE OF ORDER

Tensioner for 1/2" pitch single chain TCP 1 1/2" S. For single chain available from stock. For double chain on request.

**S** = single chain **D** = double chain

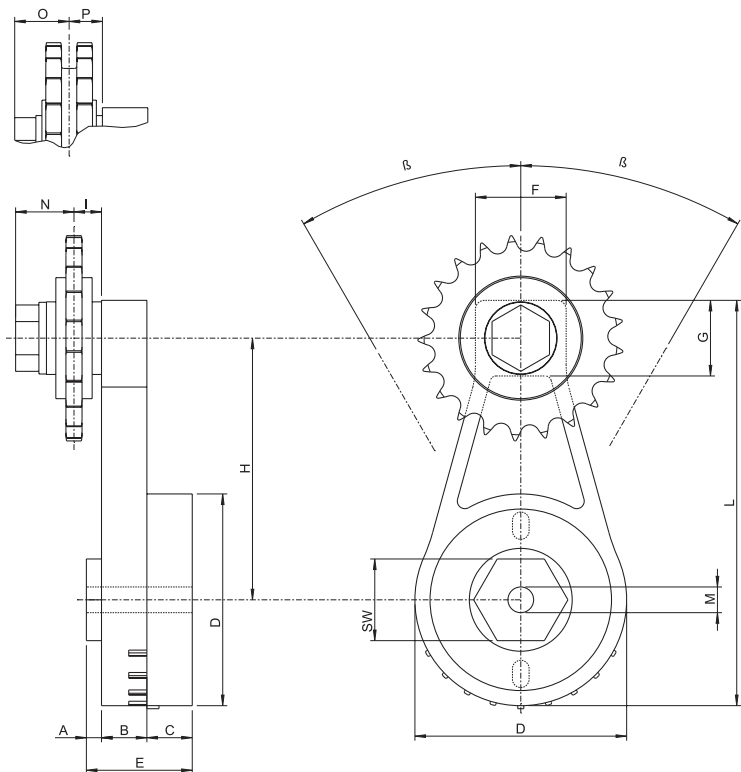



## **iwis**® TCP Type with low friction coefficient polythene head



Type TCP	Newton		Chain pitch	A	B	C	CH	D	E	F	G	H	I	L	M	N	O	P	Q	β	
	min.	max.																			
Type TCP																					
*TCP-05 – 3/8"	30	80	3/8" x 7/32"	5	15	15	24	63	35	23	23	75.5	5,5	119	M10	70	20	-	22	45°	
TCP-1 – 3/8"	50	180	3/8" x 7/32"	5	15.5	15.5	24	69	36	30	25	86.5	7	134	M10	70	20	20	22	45°	
TCP-1 – 1/2"	50	180	1/2" x 5/16"	5	15.5	15.5	24	69	36	30	25	86.5	7	134	M10	70	20	20	22	45°	
TCP-1 – 5/8"	50	180	5/8" x 3/8"	5	15.5	15.5	24	69	36	30	25	86.5	7	134	M10	90	22	25	29	45°	
TCP-2 – 5/8"	120	500	5/8" x 3/8"	7	18	18	27	90	43	34	30	100	8	159	M12	90	22	25	29	30°	
TCP-2 – 3/4"	120	500	3/4" x 7/16"	7	18	18	27	90	43	34	30	100	8	159	M12	90	22	30	29	30°	
TCP-2 – 1"	120	500	1" x 17 mm	7	18	18	27	90	43	34	30	100	8	159	M12	110	25	45	35	30°	

\* Plastic version

### TYPE TCP

- Operational temperature -50 °C to +80 °C

### EXAMPLE OF ORDER

Tensioner for 1/2" pitch single chain TCP 1 – 1/2" S. For single chain available from stock. For double chain on request.

**S** = single chain **D** = double chain

- The sprocket can be mounted on both sides

### NOTE

Assembly instruction tensioner TC type  
→ [Page 135](#)

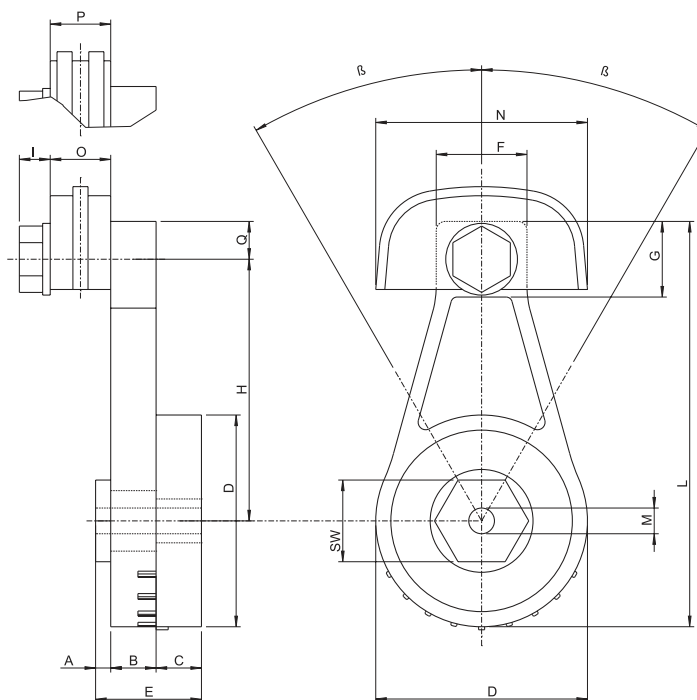

## iwis® TO Type Automatic chain tensioners



Type TO	Newton		Chain pitch	A1	A2	B	C	D	E	F	G	H	I	L	M	P	R
	min.	max.															
TO-1 – 3/8"	130	250	3/8" x 7/32"	20	20	23	12.5	11	56.2	7	58	74	110	138	–	70	100
TO-1 – 1/2"	130	250	1/2" x 5/16"	20	20	23	12.5	11	56.2	7	58	74	110	138	–	70	100
TO-1 – 5/8"	130	250	5/8" x 3/8"	20	25	23	12.5	11	56.2	7	58	74	110	138	–	70	100
TO-2 – 5/8"	180	420	5/8" x 3/8"	22	25	28	15	12.5	70.5	9	70	87	133	169	–	90	120
TO-2 – 3/4"	180	420	3/4" x 7/16"	22	30	28	15	12.5	70.5	9	70	87	133	169	–	90	120
TO-3 – 1"	300	650	1" x 17 mm	25	45	33	17.5	14.5	82	9	86	104	160	202	21	110	140
TO-3 – 1 1/4"	300	650	1 1/4" x 3/4"	25	54	33	17.5	14.5	82	9	86	104	160	202	21	110	140
TO-3 – 1 1/2"	300	650	1 1/2" x 1"	25	71	33	17.5	14.5	82	9	86	104	160	202	21	110	140
TO-05 – 3/8"	95	190	3/8" x 7/32"	20	–	25	12.5	9	60	10	53	75	120	149	22	70	100
TO-05-DP1 – 3/8"	95	190	3/8" x 7/32"	20	20	25	12.5	9	60	10	53	75	111	139	22	70	100
TO-05-DP1 – 1/2"	95	190	1/2" x 5/16"	20	20	25	12.5	9	60	10	53	75	111	139	22	70	100
TO-05-DP1 – 5/8"	95	190	5/8" x 3/8"	20	25	25	12.5	9	60	10	53	75	111	139	22	70	100

### AUTOMATIC CHAIN TENSIONERS

The automatic tensioners take up the chain slackening and keep the tension constant, without any operator attending the adjustment. The TO-AT-ET tighteners are designed to last and are made of top quality materials. Operational temperature -50 °C to +80 °C

Available on request:

- Studs and spring in stainless steel AISI 304 for the Food industry
- Special head shapes
- Version TO-05 and TO-05 DP1 with basic body in plastic execution (DELRIN). Slight type with lower tensioning force – available on request.

\* Plastic version

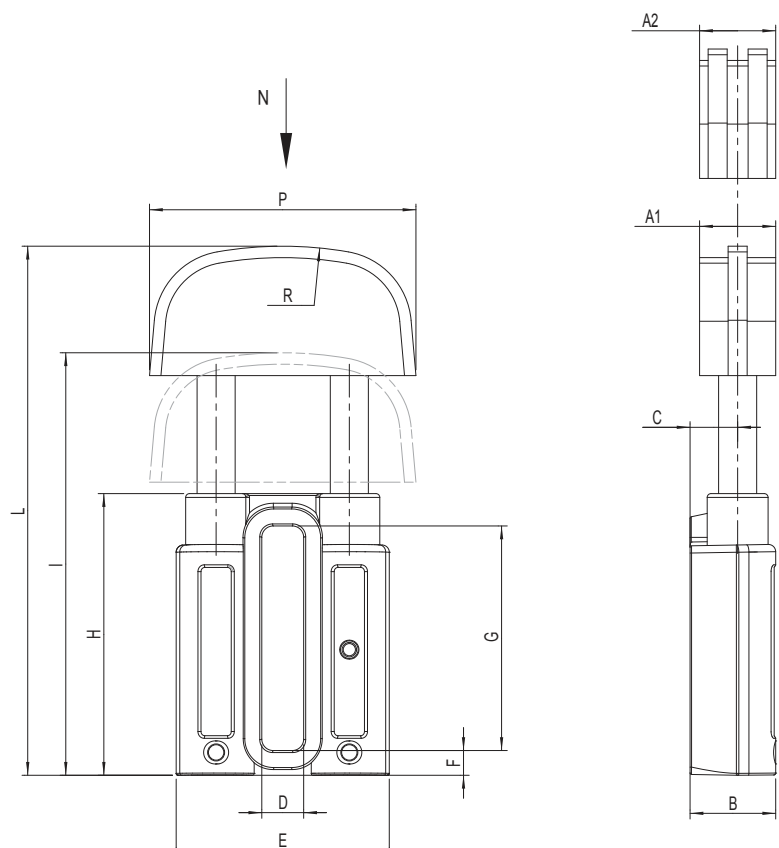

**iwis® TA Type**



Type TA	Newton		Chain pitch	A1	A2	B	C	D	E	F	G	H	I	L	M	P	R
	min.	max.															
TA-1 – 3/8"	130	250	3/8" x 7/32"	20	20	23	12.5	11	56.2	7	58	74	115	143	-	140	120
TA-1 – 1/2"	130	250	1/2" x 5/16"	20	20	23	12.5	11	56.2	7	58	74	115	143	-	140	120
TA-2 – 5/8"	180	420	5/8" x 3/8"	22	25	28	15	12.5	70.5	9	70	87	128	164	-	140	140
TA-2 – 3/4"	180	420	3/4" x 7/16"	22	30	28	15	12.5	70.5	9	70	87	128	164	-	140	140
TA-3 – 1"	300	650	1" x 17 mm	25	45	33	17.5	14.5	82	9	86	104	145	187	21	140	160
TA-3 – 1 1/4"	300	650	1 1/4" x 3/4"	25	54	33	17.5	14.5	82	9	86	104	145	187	21	140	160
TA-3 – 1 1/2"	300	650	1 1/2" x 1"	25	71	33	17.5	14.5	82	9	86	104	145	187	21	140	160
TA-3 – 1 3/4"	300	650	1 3/4" x 31 mm	29.5	-	33	17.5	14.5	82	9	86	104	145	187	21	140	160

**TA SERIES**

- Tensioning head made of low friction coefficient special wearproof plastic (dynamic friction coefficient 0.06 on dry steel)
- High tensile steel ground studs
- Self-lubricating bearings for axial slide
- Applies to reverse direction drives
- Operational temperature -40 °C to +65 °C

**EXAMPLE OF ORDER**

Tensioner for 1/2" pitch double chain  
TA 1 – 1/2" D

**S** = single chain **D** = double chain  
**T** = triple chain

N.B.: Our tensioners are supplied for chains complying to ISO standards.

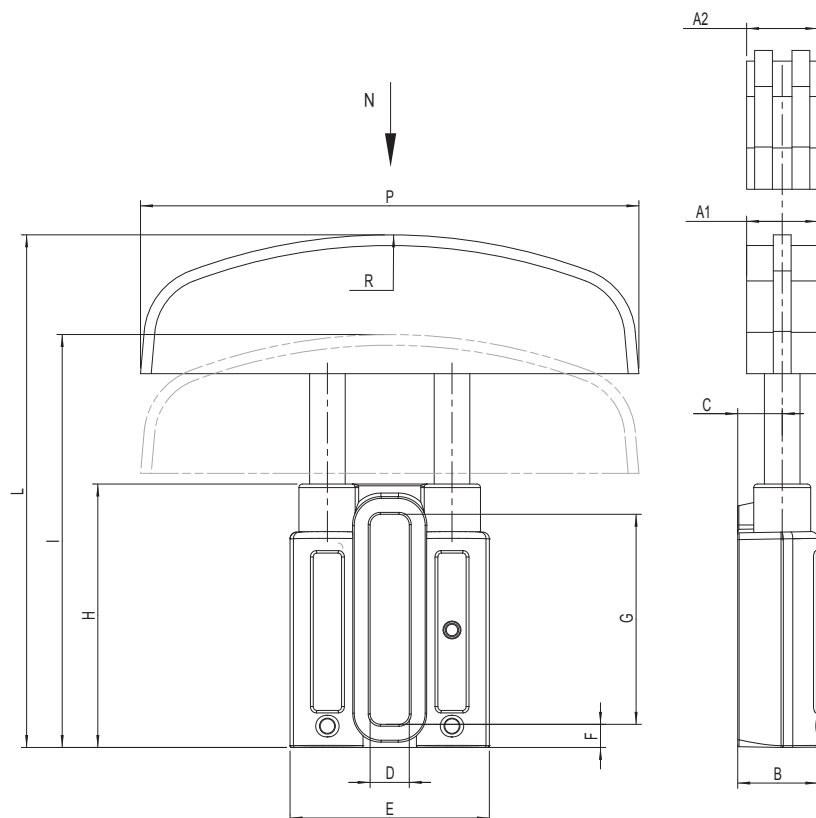

## iwis® ETR Type with sprocket and bearing



Type ETR	Newton		Chain pitch	Z	A	B	C	D	E	F	G	H	I	L	M	P	Q	R
	min.	max.																
ETR1 – 3/8"	130	250	3/8" x 7/32"	21	20	23	12.5	11	56.2	7	58	74	99	127	-	11	19.7	9.2
ETR1 – 1/2"	130	250	1/2" x 5/16"	16	20	23	12.5	11	56.2	7	58	74	99	127	-	12.5	19.7	9.2
ETR2 – 5/8"	180	420	5/8" x 3/8"	17	25	28	15	12.5	70.5	9	70	87	127	163	-	15.3	19.7	9.2
ETR2 – 3/4"	180	420	3/4" x 7/16"	15	25	28	15	12.5	70.5	9	70	87	127	163	-	17.7	19.7	9.2
ETR3 – 1"	300	650	1" x 17 mm	12	30	33	17.5	14.5	82	9	86	104	151	193	21	26.4	19.4	11.3
ETR3 – 1 1/4"	300	650	1 1/4" x 3/4"	9	30	33	17.5	14.5	82	9	86	104	151	193	-	29.7	19.4	11.5

### ETR SERIES

- Maintenance-free
- Tensioning force changeable (option)
- Resistant against oil and solvents
- Simply mounting and adjustment
- Applies to reverse direction drives
- The sprocket can be mounted on both sides
- Operational temperature -20 °C to +120 °C

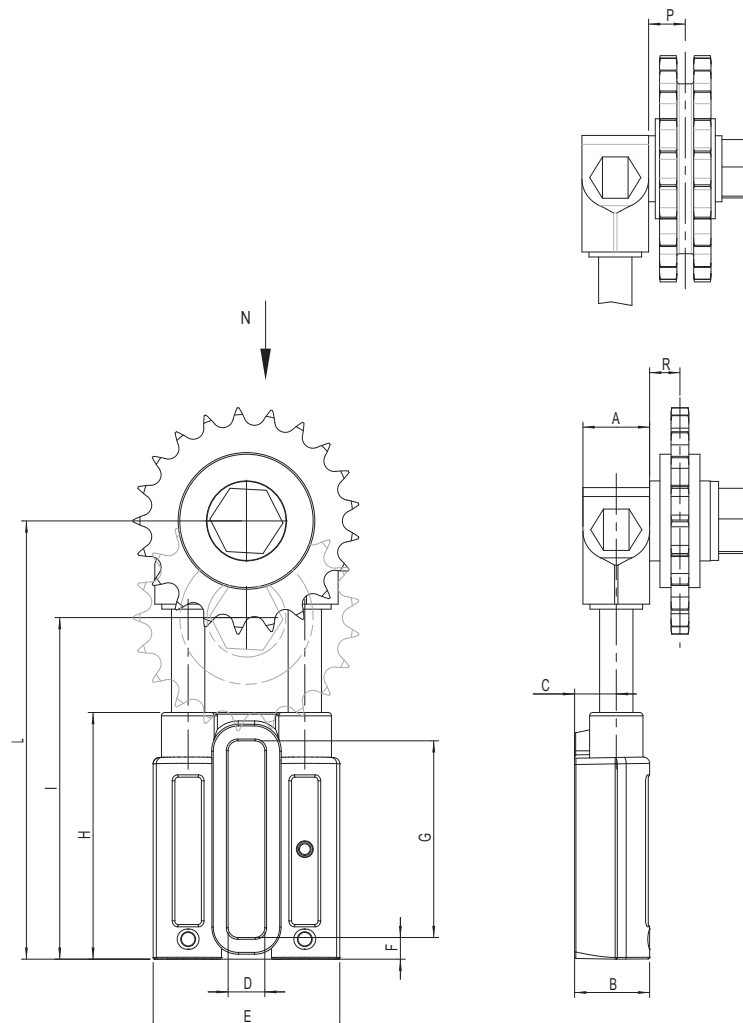

**iwis® TF Type**  
Plastic tightening head

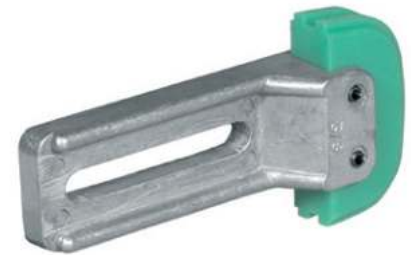

	Chain pitch	A	B	C	D	E	F	G	H	I	L	N	R	A <sub>1</sub>	A <sub>2</sub>
<b>Type TF</b>															
TF 1	3/8"	69	20	138	10	73	10.5	40	100	15	30	15	15	20	20
TF 1	1/2"	69	20	138	10	73	10.5	40	100	15	30	15	15.25	20	20.5
TF 2	5/8"	89	20	164	12	85	12.5	50	120	18	36	18	19.5	22	25
TF 2	3/4"	89	20	164	12	85	12.5	50	120	18	36	18	21.75	22	29.5
TF 3	1"	109	25	173	13	82	12.5	60	140	20	40	20	30.5	25	46
TF 3	1 1/4"	109	25	173	13	82	12.5	60	140	20	40	20	-	25	-
TF 3	1 1/2"	109	25	173	13	82	12.5	60	140	20	40	20	-	25	-

**TF TYPE**

- Wear resistant tensioning head in low friction ( $\mu = 0.06$ ) plastic
- Simple mounting and adjustment
- Operational temperature -50 °C to +80 °C

**EXAMPLE OF ORDER**

Tensioner for 1/2" pitch double chain  
TF 1 – 1/2" D

**S** = single chain   **D** = double chain  
**T** = triple chain

Our tensioners are supplied for chains complying to ISO standards.

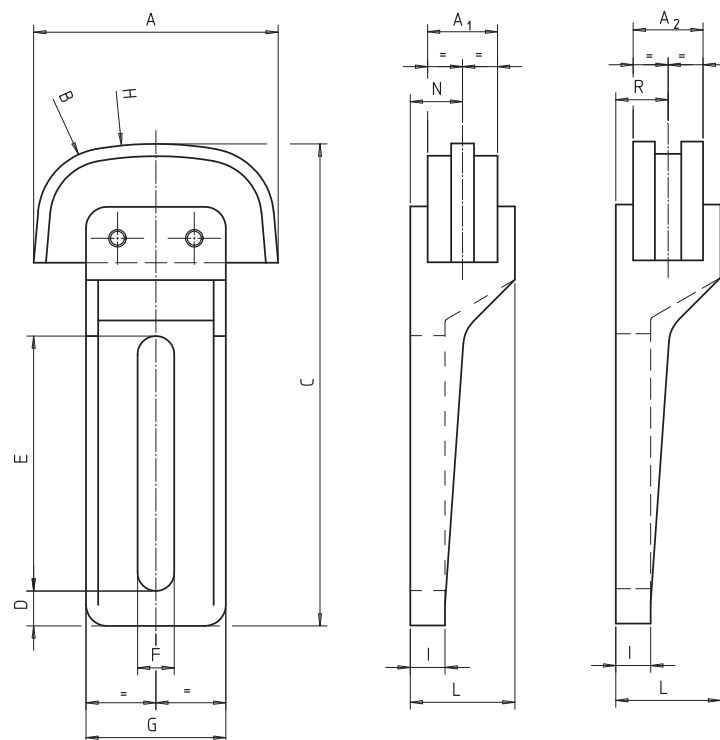

## iwis® Chain Tensioner AMS with ratchet function



for iwis chain	ISO ref.	Tensioning Unit No.	No. of teeth z	Tensioning force N	Tensioning path S mm	Adjusting range mm	Dimensions A mm	Dimensions B mm	Basic element No.	Support bracket No.	Tensioner complete with wheel
Typ AMS											
G 67	06 B-1	10	21	0-100	0-25	60	47.6	39.4	AMS 11	01	AMS 116
G 67	06 B-1	10	21	0-100	0-25	60	47.6	39.4	AMS 12	02	AMS 126
L 85	08 B-1	10	18	0-100	0-25	60	47.6	39.4	AMS 11	01	AMS 118
L 85	08 B-1	10	18	0-100	0-25	60	47.6	39.4	AMS 12	02	AMS 128
M 106	10 B-1	10	17	0-100	0-25	60	47.6	39.4	AMS 11	01	AMS 1110
M 106	10 B-1	10	17	0-100	0-25	60	47.6	39.4	AMS 12	02	AMS 1210
M 127	12 B-1	20	15	0-300	0-45	40	52.0	40.0	AMS 23	03	AMS 2312
M 1611	16 B-1	20	12	0-300	0-45	40	52.65	41.3	AMS 23	03	AMS 2316

### AMS TYPE

- Automatic retensioning
- Pawl and ratchet rebound safety mechanism
- Constant vibration damping
- Simple adjusting device
- Low in maintenance
- Resistant against oil and solvents

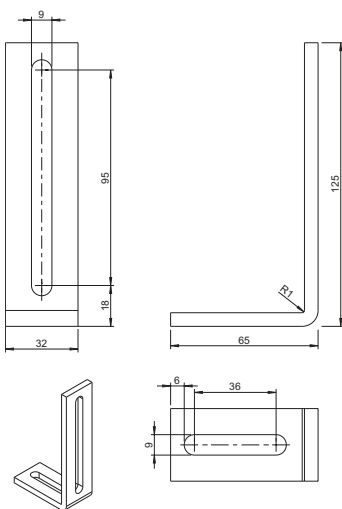

Support bracket 01

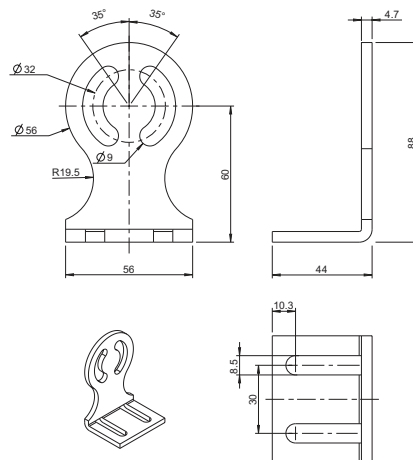

Support bracket 02

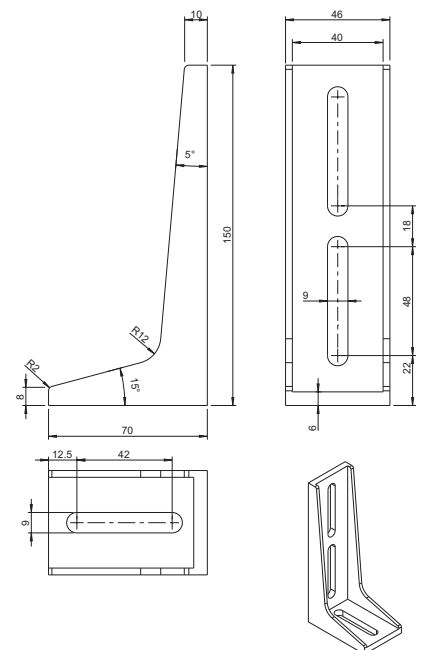

Support bracket 03

**iwis® Chain Tensioner AMS**  
 with ratchet function



AMS 10

AMS 20

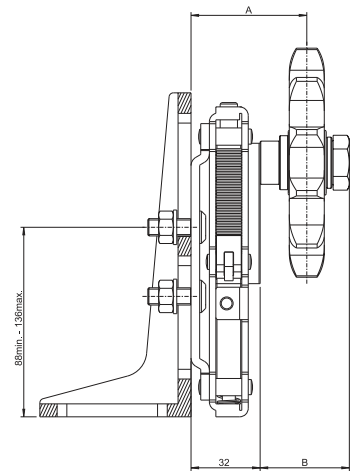
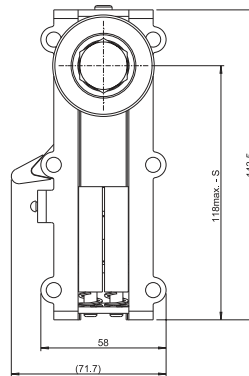
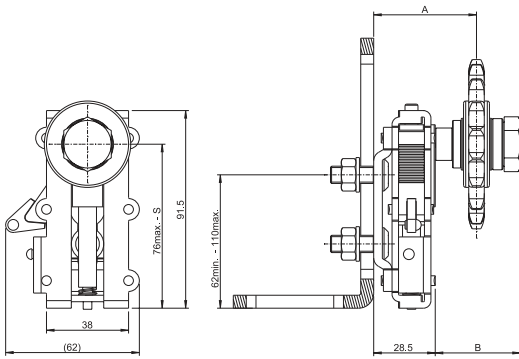

**iwis® TC Type**  
 Tensioner assembly TC Type



ALTERNATIVE A

ALTERNATIVE B

CORRECT ASSEMBLY

WRONG ASSEMBLY

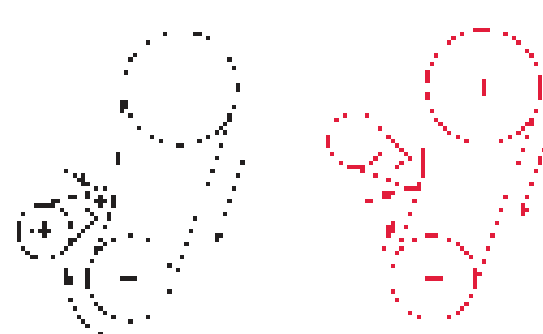
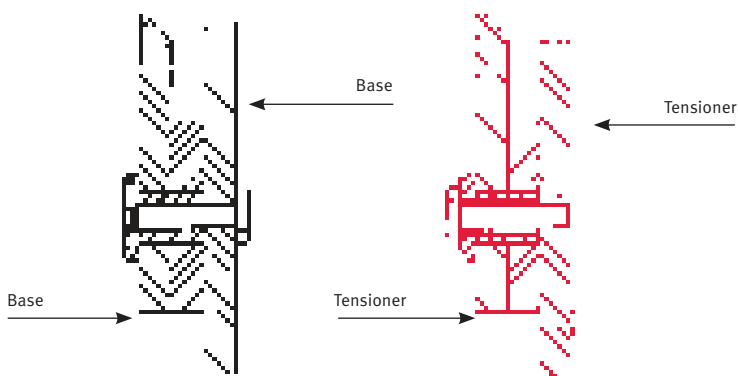





# **JWIS**<sup>®</sup> Chain Guide

Regular maintenance and lubrication are preconditions for low wear and long service life of the chain drive. The maintenance and lubrication frequency, as well as the related relubrication, are determined by the operating conditions of the application. The iwis chain guide outlines the choice of possible chain lubrications and recommended relubricants. All initial lubricants are developed especially for iwis and their composition is tailored to be the best possible for the product chain. Please contact our Technical Service Team for more information regarding the maintenance and handling of chains. We will happily advise you!

Our chain guide gives you an overview of our range of iwis initial lubricants and recommended relubricants. All initial lubricants are developed especially for iwis and their composition is tailored to meet all possible demands for our product 'chain'.



## Lubricating the **iwis**® chains iwis chain lubricants

### THE BEST POSSIBLE SOLUTION FOR EVERY APPLICATION

Sufficient and effective lubrication increases the length of life of the chains several times over. The selection of the correct lubricant and the appropriate method of lubrication guarantee best reduction of wear, sufficient protection from corrosion and optional damping characteristics.

Countless trials on specially developed test equipment and close collaboration with well known lubricant manufacturers make iwis your competent partner for all questions relating to chain lubrication.

All iwis chains are provided with sufficient, reliable, high quality initial lubrication in accordance with precisely stipulated procedures, which are the subject of constant monitoring, and delivered ready for installation.

All the initial lubricants are developed especially for iwis and their composition is tailored to be the best possible for the chain product.

### RECOMMENDATIONS

The chain drive should be cleaned with a brush before the lubricant is topped up to enable the lubricant to enter. In addition the surface of the chain can be cleaned with cleaner's naphtha or petroleum. Full submersion and washing out is not recommended.

Connecting elements (for example, connecting links), when supplied separately, have only been immersion-protected against rust and must be greased upon installation. If the connecting links are supplied together with the chains, they will have been greased with the same lubricant as the chains.

### MANUAL LUBRICATION

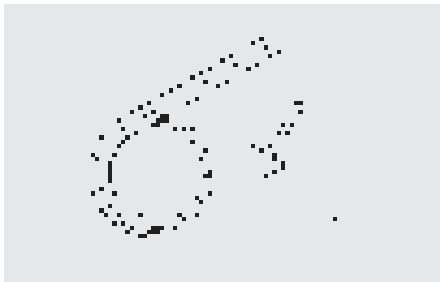

Using a paint brush, oil can or [spray can](#) for slow-running chain drives. The proven VP6-Kombi superplus (spray) is distinguished by the following characteristics:

- Synthetic high performance chain lubricant
- Optimum lubricating effect and adhesion
- Excellent ability to creep
- For normal and high temperature use up to +250 °C (+482 °F)
- Excellent corrosion protection
- Also well suited to O-ring chains

### DRIP LUBRICATION



Using drip oilers, automatic lubricant feed or central lubrication units at medium chain speeds.

### OIL BATH LUBRICATION

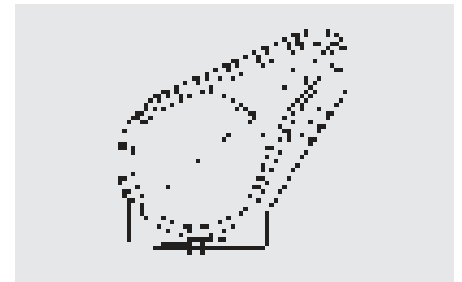

Using enclosed chain boxes and, if necessary, additional centrifugal disc for fast-running chain drives

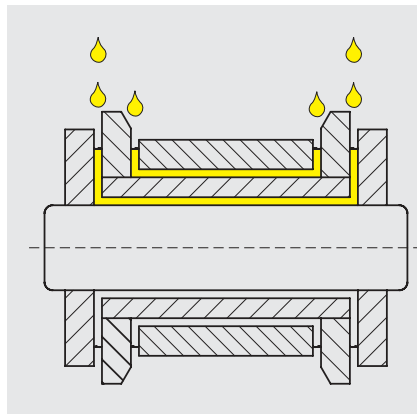

The lubricant product must be able to penetrate into the bearing area of the chain. To guarantee this, the lubricant must be applied deliberately to the gap between the inner and outer plates.

## Perfect maintenance of **iwis**® chain drives

Regular maintenance and lubrication are preconditions for low wear and long service life of the chain drive. Maintenance and lubrication frequency, as well as the related relubrication, is determined by operating conditions (tensile forces, temperature, contamination, aggressive media).

### MEASUREMENT OF STRETCHING DUE TO WEAR

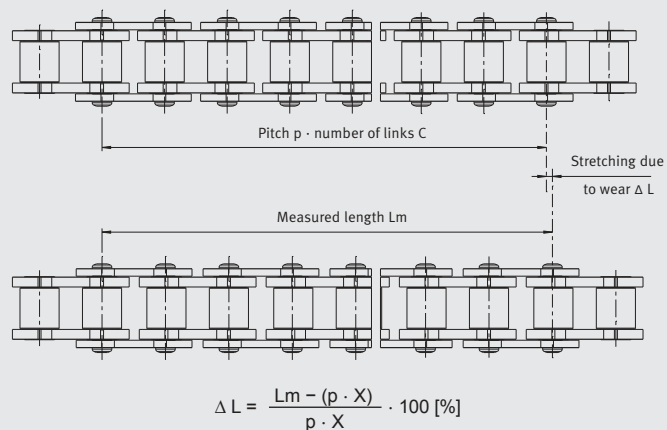

### MAINTENANCE

During **regular visual inspections** special attention should be paid to **stretching due to wear, tension, lubrication condition, and evidence of wear due to tracking errors.**

#### Checking the maximum permissible stretching due to wear:

The length of a chain is defined by the pitch  $p$  and the number of links  $X$ . In the course of time stretching due to wear occurs, and usually this can be measured without removing the chain. The difference from precise measurement with a specified measurement load is slight if measurements are conducted over the highest possible number of chain links, approximately 20 to 40.

The **chain should be replaced** at:

- max. 3 % for simple drives
- max. 2 % for high-performance drives
- max. 1 % for special applications (synchronous operation, positioning)

Controlled **retensioning** of the chains has a very positive effect on the chain life. Extreme retensioning should be avoided just as much as excessive slack. A guideline figure would be a tension load of approx. 5 % of the actual chain pulling force. In the case of chains running in parallel both strands must be tensioned equally, at best by a common shaft for both sprockets. If no automatic chain tensioning device is available, the chain must be adjusted by hand by altering the distance between the sprocket shafts. A further possibility with long drives is to shorten the chain by removing individual links, provided that wear is relatively light. Various tools are available for dismantling and reassembling the chain. These tools are available for parallel pin and shouldered pin chains.

Before **relubrication** the chains and sprockets should be **cleaned** to remove obstinate contamination and to permit the lubricant to penetrate via the back of the plates. The surface of the chain can also be cleaned using an appropriate solvent.

Complete immersion and washing is not recommended as the cleaning agent does not evaporate completely from within the chain and thus the penetration of the fresh lubricant is obstructed.

During **visual inspection** attention should be paid to evidence of chain linkplate marking and wear due to tracking errors. These are caused by misaligned sprockets or guides or by chains which are not in parallel.

Guide for alignment deviations per 100 mm axle separation:

- 0.1 mm with fast-running drives and close axle spacing;
- 0.2 mm with slow-running drives.

The sprockets should be constantly inspected and if necessary replaced. We do not recommend that new chains are used with worn sprockets.

## iwis® Lubricants

The optimum solution for every application

### A SUMMARY OF OUR INITIAL LUBRICANTS

#### IP0 Low-temperature lubricant

A low-temperature lubricant with optimum lubricating properties and consistent fluidity over the entire temperature range.

##### Technical data:

Chemical composition	Ester oil + synthetic hydrocarbon oil + UV indicator
Colour	Brown
Viscosity	Kinematic (40 °C   104 °F): 68 mm <sup>2</sup> /s
Density	Approx. 0.92 g/cm <sup>3</sup> (20 °C   68 °F)
Physical state	Liquid
Operating temperature	-40 °C (-49 °F) to +150 °C (+302 °F)

##### iwis recommendation for relubricants

- All low-temperature commercial chain oils

#### IP3 Long-lasting lubrication

Long-lasting lubrication at higher speeds, loads and temperatures. As a consequence of its high viscosity, it is absolutely resistant to spinning off over the entire temperature range.

##### Technical data:

Chemical composition	Mineral oil + synthetic hydrocarbon oil
Colour	Brown
Viscosity	Kinematic (40 °C   104 °F): 7200 - 8800 mm <sup>2</sup> /s
Density	0.9 g/cm <sup>3</sup> (20 °C   68 °F)
Physical state	Liquid
Operating temperature	0 °C (+32 °F) to +150 °C (+302 °F)

##### iwis recommendation for relubricants

- iwis VP6 Kombi Superplus (spray)
- Standard commercial high-performance chain oils

#### IP2 Standard lubricant

The proven standard lubricant with a good lubricating effect and excellent corrosion protection for applications of all kinds.

##### Technical data:

Chemical composition	Mineral oil + synthetic hydrocarbon oil
Colour	Brown
Viscosity	Kinematic (40 °C   104 °F): 12 cm <sup>2</sup> /s (1200 cSt)
Density	0.9 g/cm <sup>3</sup> (20 °C   68 °F)
Physical state	Liquid
Operating temperature	-10 °C (+14 °F) to +80 °C (+176 °F)

##### iwis recommendation for relubricants

- iwis VP6 Kombi Superplus (spray)
- All standard commercial chain oils

#### IP4 High-temperature lubricant

Thermally stable high-temperature lubricant with good wear- and corrosion-resistance. Low evaporation rate in the temperature range from 32° to +482 °F. Forms no residue at temperatures above 482 °F. NSF-H2 approved.

##### Technical data:

Chemical composition	Ester oil + synthetic hydrocarbon oil
Colour	Yellow
Viscosity	Kinematic (40 °C   104 °F): 11.75 cm <sup>2</sup> /s
Density	0.91 g/cm <sup>3</sup> (20 °C   68 °F)
Physical state	Liquid
Operating temperature	0 °C (+32 °F) to +250 °C (+482 °F)

##### iwis recommendation for relubricants

- iwis VP6 Kombi Superplus (spray)
- High-temperature chain oils from various suppliers, suitable for operating temperatures over +250 °C (+482 °F) with a proportion of solid lubricant

## A SUMMARY OF OUR INITIAL LUBRICANTS

### IP9 Corrosion-protection

The corrosion-protection for preservative use with a low lubricant effect.

#### Technical data:

Chemical composition	Synthetic hydrocarbon oil + ester oil
Colour	Brown
Viscosity	Kinematic (40 °C   104 °F): 20 mm <sup>2</sup> /s
Density	Approx. 0.86 g/cm <sup>3</sup> (20 °C   68 °F)
Physical state	Liquid
Operating temperature	0 °C (+32 °F) to +150 °C (+302 °F)

#### iwis recommendation for relubricants

- iwis VP6 Kombi Superplus (spray)
- All standard commercial chain oils

### IP16 Food-grade lubricant

The lubricant for food use with good wear- and corrosion-resistance. Meets the requirements of USDA-H1 and LMBG – authorised for contact with food.

#### Technical data:

Chemical composition	Synthetic hydrocarbon oil + ester oil
Colour	Yellow
Viscosity	Kinematic (40 °C   104 °F): 15 cm <sup>2</sup> /s (1500 cSt)
Density	Approx. 0.86 g/cm <sup>3</sup> (20 °C   68 °F)
Physical state	Liquid
Operating temperature	-25 °C (-13 °F) to +120 °C (+248 °F)

#### iwis recommendation for relubricants

- Food-grade chain lubricants

### IP14 Stove-enamelled dry lubricant

Dry lubricant for slow-running chain drives and low to medium loads.

#### Technical data:

Colour	Dark grey
Operating temperature	-70 °C (-94 °F) to +250 °C (+482 °F)

#### iwis recommendation for relubricants

- iwis VP6 Kombi Superplus (spray)
- Chain oils with a proportion of solid lubricant e.g. graphite or molybdenum disulphide (MoS<sub>2</sub>)

### IPW High-performance lubricating wax

The handling-resistant high-performance lubricating wax with very high wear protection permits significantly longer intervals between applications of lubricant. Problem-free use as a „barrier grease“ in all environments where dust and powder are present.

#### Technical data:

Chemical composition	Wax + mineral oil + synthetic hydrocarbon oil
Colour	Beige
Density	Approx. 0.89 g/cm <sup>3</sup> (20 °C   68 °F)
Physical state	Paste
Operating temperature	-10 °C (+14 °F) to +80 °C (+176 °F)

#### iwis recommendation for relubricants

- iwis VP6 Kombi Superplus (spray)
- Standard commercial high-performance chain oils

**iwis® Lubricants**

Overview of all temperature ranges

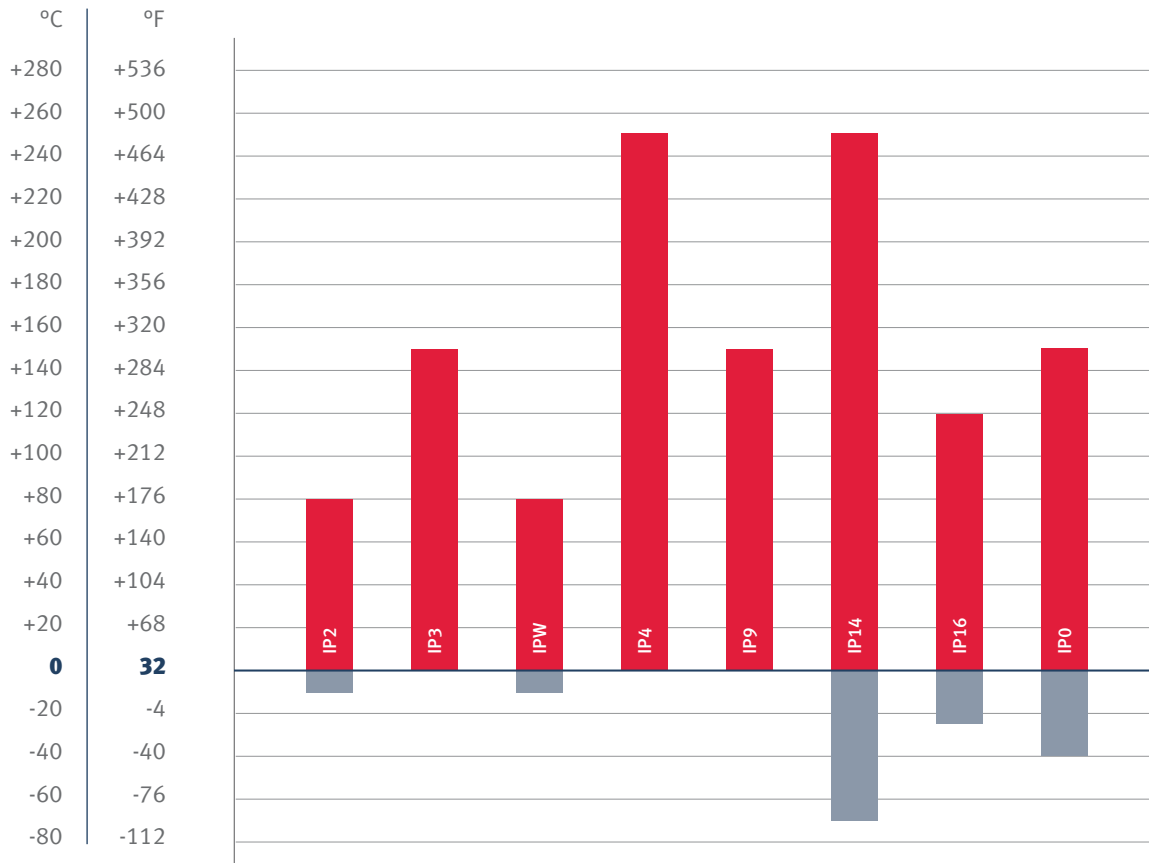

**IP2**

Standard lubricant with good lubricating properties and outstanding corrosion protection for all applications.

**IP3**

Long-life lubricant for high speeds, absolutely non-drip/non-splash.

**IPW**

High-adhesion, high-performance lubricant wax with extremely high wear protection that allows significantly longer relubrication intervals. Can be used without problems in dusty and powdery environments.

**IP4**

Thermally stable high-temperature lubricant with good protection against wear and corrosion.

**IP9**

Preservative corrosion protection with minimal lubricating effect.

**IP14**

Dry lubrication for slow-running chain drives and low to medium loads.

**IP16**

Food-grade lubricant with good protection against wear and corrosion. Meets the high standards of USDA-H1 and LMBG.

**IP0**

Low-temperature lubricant with optimum lubricating properties and consistent fluidity over the entire temperature range.

## Lubricating the **iwis**® chains Relubricants

### RECOMMENDED RELUBRICANT

The life of a chain is dependent to a decisive extent on correct and adequate topping up of the lubricant. As a consequence of the oscillating movements of the chain link, the initial lubricant is used up in the course of time depending on the operating conditions. If the lubricant is topped up regularly, the chain is mainly within the range of fluid and mixed friction. An absence of lubricant or badly selected relubricants cause dry friction, which leads to the formation of fretting corrosion and increased wear of the chain.

The selection of the lubricant and the correct lubrication technique is decisive for effective relubrication.



### **VP6** iwis VP6 Kombi Superplus Spray

The iwis VP6 Kombi Superplus Spray is a high-adhesion, high temperature chain oil for diverse industrial chain applications.

#### Technical data:

Chemical composition	Synthetic hydrocarbon oil
Colour	Green, transparent
Viscosity	Kinematic, approx. 1800 – 2200 mm <sup>2</sup> /s (40 °C   104 °F)
Density	Approx. 0.9 g/cm <sup>3</sup> (20 °C   68 °F)
Physical state	Aerosol
Operating temperature	0 °C (+32 °F) to +250 °C (+482 °F)

#### Advantages

- Very high temperature stability
- Low evaporation
- Very good adhesion properties
- Good penetration despite high viscosity
- Extremely high wear protection

### RELUBRICANTS

should possess the following characteristics – depending on the application:

- Adhesiveness
- Compatibility with initial lubricant
- Corrosion protection
- Load-bearing capacity of lubricant film
- Ability to creep
- Lubrication of emergency running
- High viscosity and simultaneous ability to flow
- High-temperature stability
- Water-repellent
- Resistance to media etc.

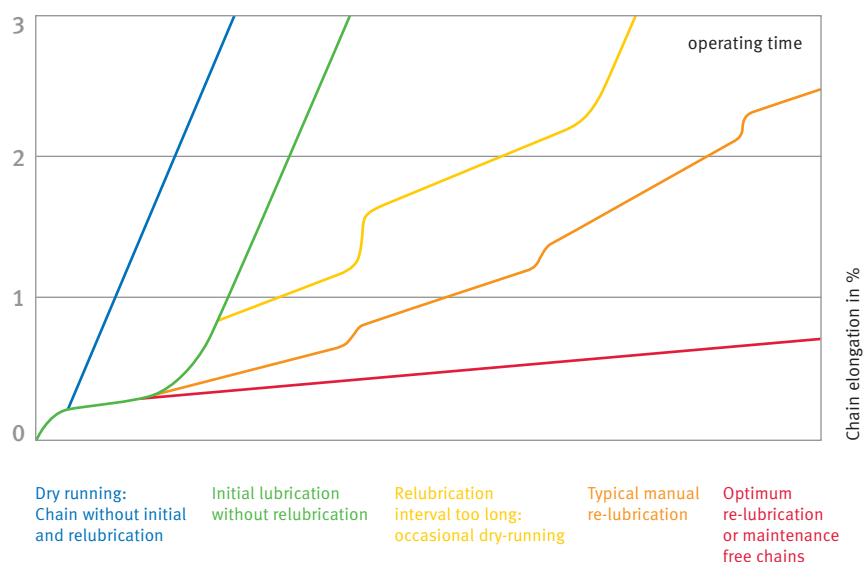

## **iwis**® Chain Engineering Important tools for your benefit



### CHAIN DESIGN

We would be happy to help you design your chain drive. Simply fill in the necessary details on our downloadable form. Then once you have completed the form, just click on the button at the bottom to send it via your e-mail client to [chaindrive@iwis.com](mailto:chaindrive@iwis.com).

[www.iwis.de/chain-design](http://www.iwis.de/chain-design)

### CAD DATABASE

#### Download, import, go!

Our CAD Database contains 3D models (in over 30 data formats) of standard roller chains and connecting links to make design work easier for you.

[www.iwis.de/cad](http://www.iwis.de/cad)

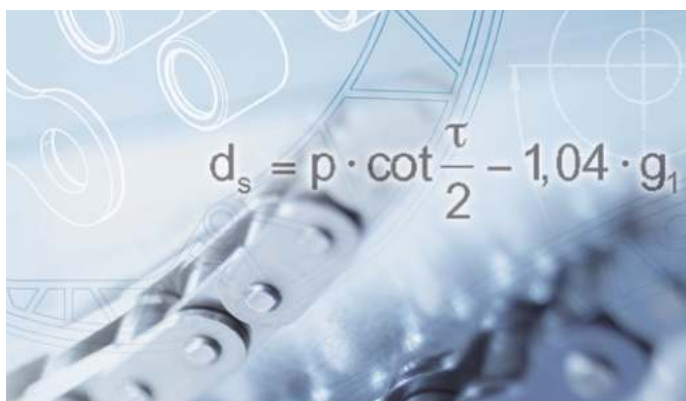

### CHAIN ENGINEERING PROGRAM

iwis provides you with a special PC-Software serving as support for the specification of the individual chain drive design or rather the preselection of the appropriate chain. Please ask our Customer Service Team!

[www.iwis.com/chain-calculation](http://www.iwis.com/chain-calculation)



### CHAIN ENGINEERING HANDBOOK

The Chain Engineering Handbook presents a synopsis of the technical knowledge about chain drives that a designer needs for configuration of a drive system. Also contains useful calculation examples and descriptions of typical application cases.

[www.iwis.de/downloads](http://www.iwis.de/downloads)



## **iwis**® Chain Guidelines

Which application demands which chain type?

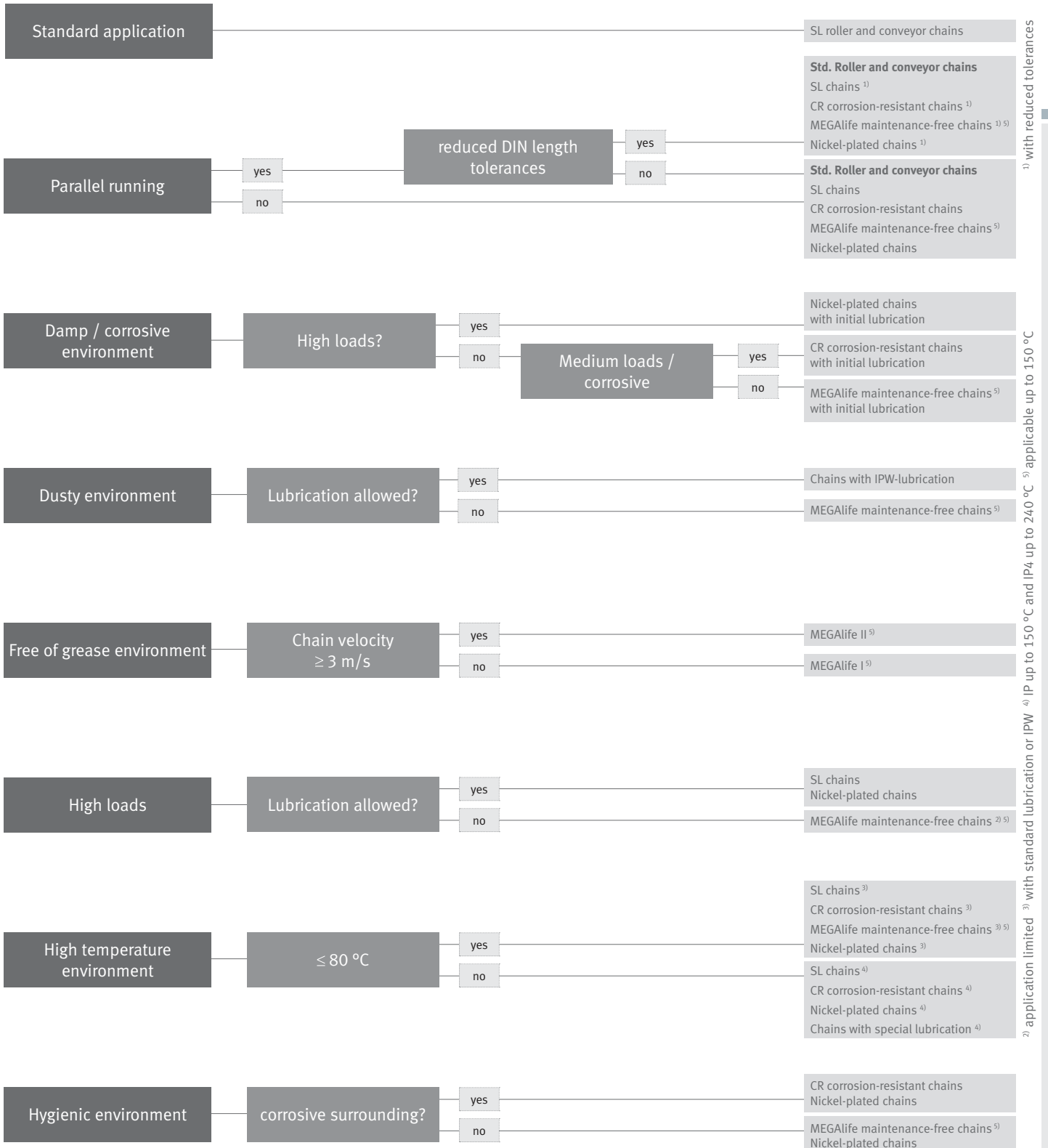

## iwis® Chain Guidelines

### Important information

#### IMPORTANT NOTICE

The following guidelines support you in choosing the right chain. However, please note that each application is individual. The result should in no case serve as a basis for your order. Therefore please refer to our professional employees who are happy to submit an individual order to you. We do not assume any guarantee or liability.

#### FOR MORE INFORMATION ON

- SL chains  
→ Pages **16** to **19**
- Nickel-plated chains  
→ Pages **16** to **19**
- MEGAlife maintenance-free chains  
→ Page **40**
- CR corrosion-resistant chains  
→ Page **66**

#### CHAIN FABRICATION LENGTHS

- 5 m
- 10 m
- 10 feet

Adjusted lengths can either be supplied open or closed. Special lengths (e.g. on coils) are available on request and depending on chain type.

#### OUR CONVEYOR CHAINS

If a parallel run is necessary, iwis can manufacture and supply chain strands with precisely harmonised lengths, bundled together and marked accordingly. This is in particular important for chains with opposite cam or angle side plates.

#### PRICE SUPPLEMENTS

Price supplements will be calculated for:

- adjusted lengths
- special lubrications
- reduced tolerances
- short lengths
- special coatings
- nickel-plated chains and single parts  
Prices on enquiry.

#### CUSTOM-MADE CHAINS

Special chains made according to customer drawings are possible. Prices on enquiry. Minimum order quantity is 50 m.

#### MINIMUM ORDER QUANTITIES FOR CONNECTORS AND CRANKED LINKS

Chain dimensions	Inner link / Outer link / Connecting link	Cottered Link
6 mm – 3/4"	20 ea	10 ea
1" – 1 1/4"	10 ea	10 ea
Duplex – Triplex	5 ea	5 ea
Parts over 1 1/4"	1 ea	1 ea



High Precision Chains



Engineering Manual



MEGAlife Roller Chains



Transfer Chains



Spike Chains



Flat Top Chains



Drive and Conveyor Chains



Sprockets and Drive Components



Roller- and Conveyor Chains



Agricultural Chains



All product catalogs and flyers, as well as our iwis Engineering Manual can be downloaded on our website: [iwis.com/catalogs](http://iwis.com/catalogs)

# Our subsidiaries

## Germany

iwis antriebssysteme GmbH & Co. KG  
Albert-Roßhaupter-Straße 53  
81369 München  
Tel. +49 89 76909-1600  
Fax +49 89 76909-1198  
sales-muenchen@iwis.com

## Germany

iwis antriebssysteme GmbH  
Essener Straße 23  
57234 Wilnsdorf  
Tel. +49 2739 86-0  
Fax +49 2739 86-22  
sales-wilnsdorf@iwis.com

## Germany

iwis agrisystems  
Schützenweg 5  
36205 Sontra  
Tel. +49 5653 9778-0  
Fax +49 5653 9778-26  
agrisystems@iwis.com

## Brazil

iwis Sistemas de Transmissão  
de Energia Mecânica Ltda.  
Rua Bento Rosa, nº 1816  
Bairro Hidráulica  
95.900-000 Lajeado, RS  
Tel. +55 51 3748-7402  
salesbrazil@iwis.com

## China

iwis drive systems (Suzhou) Co., Ltd.  
No. 266 LvliangShan Road  
215153 Suzhou SND  
Tel. +86 512 8566-3010  
Fax +86 512 8566-3009  
salescn@iwis.com

## France

iwis antriebssysteme GmbH  
10 rue du Luxembourg  
69330 Meyzieu  
Tel. +33 4374515-70  
Fax +33 4374515-71  
salesfr@iwis.com

## Great Britain

iwis drive systems Ltd.  
Unit 8c Bloomfield Park  
Bloomfield Road, Tipton  
West Midlands, DY4 9AP  
Tel. +44 12 15213600  
Fax +44 12 15200822  
salesuk@iwis.com

## India

iwis drive systems India Pvt. Ltd.  
„Anisha“, Unit No3, SR. No. 84/1  
Regency Cosmos, Baner Mahalunge Road,  
Opposite to Amruta Hotel  
Baner, Pune, Maharashtra-411045  
Tel. +91 20 67110305  
salesin@iwis.com

## Italy

iwis drive systems Srl  
Via Carlo Rota, 10  
20090 Monza (MB)  
Tel. +39 340 9296142  
Fax +49 89 7690949-1726  
italia@iwis.com

## Canada

iwis drive systems, Inc.  
101-19097, 26th Avenue,  
Surrey BC V3Z 3V7  
Tel. +1 604 560-6395  
Fax +1 604 560-6397  
salesca@iwisusa.com

## South Korea

iwis engine systems Korea Co., Ltd.  
Office No. 403-2, 322 Yanghyeon-ro  
(Yatap-dong, Korea Design Center)  
Bundang-Gu, Seongnam Si,  
Gyeonggi-Do, Korea (ZIP) 13496  
Tel. +82 31 788-7545  
saleskor@iwis.com

## Switzerland

iwis AG Kettentechnik  
Bahnweg 4 (Postfach)  
5504 Othmarsingen  
Tel. +41 62 8898999  
Fax +41 62 8898990  
info@iwis-ketten.ch

## Scandinavia

iwis Scandinavia  
Tel. +45 31 390819  
sales-scandic@iwis.com

## South Africa

iwis drive systems, (Pty) Ltd.  
Unit 3, 127 Koornhof Road  
Meadowdale, 1613  
Tel. +27 11 392-2306  
Fax +27 11 392-3295  
salessa@iwis.com

## Czechia

iwis antriebssysteme spol. s r.o.  
Přísecká 893  
38601 Strakonice  
Tel. +420 383 411811  
Fax +420 383 321695  
salescz@iwis.com

## Turkey

iwis tahrik sistemleri ltd. sti.  
Aydınlı - BİRLİK Org. San. Bol.  
5. Sokak No. 18/Z1  
34953 Tuzla-Istanbul  
Tel. +90 216 912 4947  
salestr@iwis.com

## USA

iwis drive systems, LLC  
Building 100, 8266 Zionsville Road  
Indianapolis, IN 46268  
Tel. +1 317 821-3539  
Fax +1 317 821-3569  
sales-us@iwis.com

[www.iwis.com](http://www.iwis.com)

Your sales representative

**iwis**  
wir bewegen die welt